

Instructions - Parts



PCF™ with PrecisionSwirl™

3A2098H

Precision Dispense System

EN

Electronically-controlled fluid metering system that provides precise continuous flow of up to four single-component sealants and adhesives through closed-loop technology.

**Not for use in explosive atmospheres or hazardous locations.
For professional use only.**



Important Safety Instructions

Read all warnings and instructions in this manual. Save these instructions.

See page 4 for model information. See page 5 for maximum working pressure and approvals.

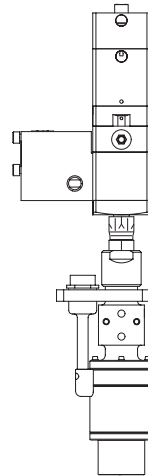

*Optional PrecisionSwirl Orbital
Dispenser (sold separately)*

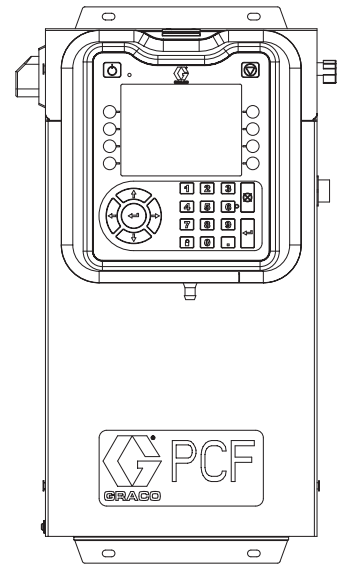

PCF Control Center

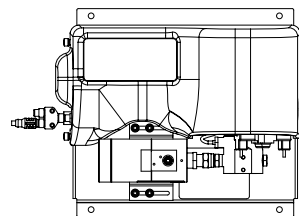

PCF Fluid Plate

IMPORTANT:

This manual does not apply to some PCF systems. See note on page 3 to verify this is the correct manual for your PCF system.



Contents

Related Manuals	3	Operation	40
Models	4	Startup	40
Fluid Plate Kits	5	Load Material	40
Expansion Swirl Enclosure Assemblies	6	Maintenance Mode Operation	41
PrecisionSwirl Orbital Dispenser Assemblies ...	6	Automation Control (Normal Operation)	45
Automation Gateway Assemblies	7	Jobs	45
Swirl Control DGM	7	Styles	46
Warnings	8	Precharge Modes	47
System Configurations	10	Typical Job Cycle	49
Typical Installation - Single Swirl, Single Fluid Plate	10	Pressure Relief Procedure	57
Typical Installation - Multiple Fluid Plates, No Swirl	11	Shutdown	58
Dispensers	11	USB Data	59
Typical Installation - Multiple Fluid Plates, Multiple	12	USB Logs	59
Swirl Dispensers	12	System Configuration Settings File	60
Overview	13	Custom Language File	60
System Overview	13	Download Procedure	61
System Components	13	Upload Procedure	61
Fluid Plate Assembly Overview	14	Troubleshooting	62
Control Center Assembly Overview	16	Fluid Plates	62
Key Tokens	20	Flow Meter	63
Installation	21	Fluid Regulator	63
Before Installation	21	Dispense Valves	64
Overview	21	Gateway Module	65
Install Control Center	22	LED Diagnostic Information	65
Install Fluid Plate Assemblies	24	Errors	66
Install Cable Assemblies	28	View Errors	66
Install Gateway Module Interface	30	Diagnose Errors	66
System Setup	32	Event and Error Codes and Troubleshooting ..	67
Overview	32	Maintenance	76
Configure System	32	Maintenance Schedule	76
Configure Control Settings	33	Advanced Display Module (ADM)	77
Configure Mode Settings	34	Upgrade Gateway Module Software	77
Configure Delay Settings	34	Upgrade Gateway Module Fieldbus Map	78
Configure Flow Meter Settings	35	Upgrade Fluid Control Module (FCM) Software	79
Configure Pressure Loop Settings	35	Air Filter Maintenance	79
Adjust Pressure Sensors	36	Swirl Dispensers	79
Configure Errors	36	Repair	80
Setup Maintenance Schedule/Parameters	37	Fluid Plate Assembly	80
Configure Valve to Swirl Association and Motor	37	Control Center Assembly	87
Error Type	37	Parts	91
Configure Swirl Settings	38	Control Centers	91
Configure Gateway Settings	38	Control Center and Expansion Swirl Enclosure	
Setup Styles	38	Parts	92
Configure Advanced Settings	38	Fluid Plate Assembly Parts	94
On/Off Delays	39		

Appendix A - Advanced Display Module (ADM) . 99
 Display Overview 99
 Display Details 99
 Setup Mode 101
 Run Mode 110

Appendix B - Discrete Gateway Module (DGM)
Connection Details 115
 D-Sub Cable 123793 115
 D-Sub Cable 123792 and Breakout Board 123783
 116
 DGM Digital Input 119
 DGM Digital Outputs 120
 DGM Analog Inputs 121
 DGM Analog Outputs 121

Appendix C - Communications Gateway Module (CGM) Connection Details 122
 Install Fieldbus Connections 122
 CGM I/O Data Map 125

Appendix D - I/O Signal Descriptions 138
 Automation Inputs 138
 Automation Outputs 139

Technical Data 140
 Control Center Assembly Technical Data 140
 Fluid Plate Assembly Technical Data 141
 Swirl Dispenser Technical Data 141

Graco Standard Warranty 142
Graco Information 142

Related Manuals

The following is a list of component manuals written in English. These manuals and any available translations can be found at www.graco.com.

Manual	Description
313377	Original PCF Instructions - Parts (see the note below)
309403	PrecisionSwirl Orbital Dispenser
307517	Mastic Fluid Regulators Instructions-Parts
308647	Fluid Pressure Regulators Instructions-Parts
309834	Helical Gear Fluid Flow Meters Instructions-Parts

NOTE: In the Advanced screens on your system, if the Advanced Display software part number shown is 16F528 or 15V769 then this manual does not apply to your system; refer to manual 313377 for your system. Otherwise, the part number shown should be 16K405 and you should use this manual.

ADM Software Part No. 16F528 or 15V769 (see manual 313377)



12/17/10 14:54	Style	Advanced	Gateway
System Off	No Active Errors		
Module	Software Part #	Software Version	
Advanced Display	16F528	1.01.001	2
Fluid Plate	15V645	1.03.001	
Gateway	16A626	1.03.006	3
USB Configuration	16C954	1.02.001	1

ADM Software Part No. 16K405 (use this manual)



11/17/11 14:00	Gateway	Advanced	Fluid Plate 1
Active	No Active Errors		
Module	Software Part #	Software Version	
Advanced Display	16K405	1.02.011	3
USB Configuration	16J874	1.01.002	
Gateway	16J872	1.01.006	4
Fluid Plate 1	16J873	1.01.012	
Fluid Plate 2	16J873	1.01.009	
Swirl Control 1	16J872	1.01.006	1
Swirl Control 2	16J872	1.01.006	2

Models

Check the identification (ID) plate for the 6-digit part number of the fluid metering system. Use the following matrix to define the construction of the system, based on the six digits. For example, Part **PF1110** represents a PCF fluid metering system (**PF**), a two style system (**1**), a fluid plate with a cartridge regulator and no meter (**1**), a DeviceNet™ user interface (**1**) with a 100-240 Vac power supply (**0**).

NOTE: To order replacement parts, see Parts section in this manual. The digits in the matrix do not correspond to the Ref. Nos. in the Parts drawings and lists.

PF	1		1		1		0		
	Third Digit		Fourth Digit		Fifth Digit		Sixth Digit		
	Style/Size		Fluid Plate		User Interface		Voltage		
		Description		Regulator	Meter		Description		Description
PF (Precision Continuous Flow)	1	2 Styles	1	*Cartridge	None	0	◆Discrete	0	100 - 240 Vac
	2	16 Styles	2	*Mastic	None	1	DeviceNet™	1	24 Vdc
	3	256 Styles	3	*Cartridge	High Resolution	2	EtherNet/IP™	2	100 - 240 Vac with Integrated Swirl
			4	*Mastic	High Resolution	3	PROFIBUS™	3	24 Vdc with Integrated Swirl
			5	Heated Mastic	Heated Standard Resolution	4	PROFINET™		
			6	Heated Mastic	None				
			7	*Cartridge	Ultra High Resolution				

◆ Discrete Gateway systems do not include automation interface cables. The following Graco accessories are available for wiring to the automation system. Installers should follow **Appendix B - Discrete Gateway Module (DGM) Connection Details**, page 115, for custom wiring.

For single fluid plate systems only: 50 ft (15 m) cable with flying leads (123793)

All systems: Breakout board (123783) and 50 ft (15 m) cable (123792)

NOTE: 256 styles option is not available with Discrete Gateway systems.

* These fluid metering systems have ETL certification.

NOTE: Fluid metering systems with heated mastic regulators are not ETL certified.



Intertek

9902471

Certified to CAN/CSA C22.2 No. 61010-1

Conforms to
UL 61010-1

① This product has been tested to the requirements of CAN/CSA-C22.2 No. 61010-1, second edition, including Amendment 1, or a later version of the same standard incorporating the same level of testing requirements.

Fluid Plate Kits

NOTE: The fluid plate kit numbers listed below include a CAN splitter. The fluid plate assembly included in each PFxxxx assembly does not include a CAN splitter.

Fluid Plate Kit	Used by Model	Maximum Working Pressure	Description	Includes:		
				Regulator	Flow Meter	FCM Key Token
24B958	PF13xx	6000 psi (41 MPa, 414 bar)	Cartridge Regulator, High Resolution Flow Meter, 2 styles	244734	246652	16M100
24B959	PF11xx	6000 psi (41 MPa, 414 bar)	Cartridge Regulator, No Flow Meter, 2 styles	244734	---	16M101
24B960	PF14xx	5000 psi (35 MPa, 345 bar)	Mastic Regulator, High Resolution Flow Meter, 2 styles	246642	246652	16M100
24B961	PF12xx	5000 psi (35 MPa, 345 bar)	Mastic Regulator, No Flow Meter, 2 styles	246642	---	16M101
24B962	PF15xx	5000 psi (35 MPa, 345 bar)	Heated Mastic Regulator, Standard Resolution Heated Flow Meter, 2 styles	246643	246340	16M100
24C901	PF16xx	5000 psi (35 MPa, 345 bar)	Heated Mastic Regulator, No Flow Meter, 2 styles	246643	---	16M101
24J873	PF17xx	6000 psi (41 MPa, 414 bar)	Cartridge Regulator, Ultra High Resolution Flow Meter, 2 styles	244734	16E993	16M100
24K801	PF23xx	6000 psi (41 MPa, 414 bar)	Cartridge Regulator, High Resolution Flow Meter, 16 styles	244734	246652	16M102
24K802	PF21xx	6000 psi (41 MPa, 414 bar)	Cartridge Regulator, No Flow Meter, 16 styles	244734	---	16M103
24K803	PF24xx	5000 psi (35 MPa, 345 bar)	Mastic Regulator, High Resolution Flow Meter, 16 styles	246642	246652	16M102
24K804	PF22xx	5000 psi (35 MPa, 345 bar)	Mastic Regulator, No Flow Meter, 16 styles	246642	---	16M103
24K805	PF25xx	5000 psi (35 MPa, 345 bar)	Heated Mastic Regulator, Standard Resolution Heated Flow Meter, 16 styles	246643	246340	16M102
24K806	PF26xx	5000 psi (35 MPa, 345 bar)	Heated Mastic Regulator, No Flow Meter, 16 styles	246643	---	16M103
24K807	PF27xx	6000 psi (41.4 MPa, 414 bar)	Cartridge Regulator, Ultra High Resolution Flow Meter, 16 styles	244734	16E993	16M102
24K808	PF33xx	6000 psi (41 MPa, 414 bar)	Cartridge Regulator, High Resolution Flow Meter, 256 styles	244734	246652	16M104
24K809	PF31xx	6000 psi (41 MPa, 414 bar)	Cartridge Regulator, No Flow Meter, 256 styles	244734	---	16M105
24K810	PF34xx	5000 psi (35 MPa, 345 bar)	Mastic Regulator, High Resolution Flow Meter, 256 styles	246642	246652	16M104
24K811	PF32xx	5000 psi (35 MPa, 345 bar)	Mastic Regulator, No Flow Meter, 256 styles	246642	---	16M105
24K812	PF35xx	5000 psi (35 MPa, 345 bar)	Heated Mastic Regulator, Standard Resolution Heated Flow Meter, 256 styles	246643	246340	16M104
24K813	PF36xx	5000 psi (35 MPa, 345 bar)	Heated Mastic Regulator, No Flow Meter, 256 styles	246643	---	16M105
24K814	PF37xx	6000 psi (41 MPa, 414 bar)	Cartridge Regulator, Ultra High Resolution Flow Meter, 256 styles	244734	16E993	16M104

Expansion Swirl Enclosure Assemblies

The following enclosures are ETL approved. Assemblies PFxxx2, and PFxxx3 are setup for one PrecisionSwirl Orbital Dispenser. If you wish to have additional swirl dispensers, order one expansion PrecisionSwirl assembly below for each. Systems with a DGM as the automation gateway can have up to two swirl dispensers total. Systems with a CGM as the automation gateway can have up to four swirl dispensers total.

Part	Description
16M350	100 - 240 Vac
16M351	24 Vdc

PrecisionSwirl Orbital Dispenser Assemblies

See manual 309403.

Version	Part, Series	Coupler Offset	Typical Application	Maximum Working Pressure
Standard	243402, B	0.012 in. for narrow bead widths	Hem flange and after hem	3500 psi (24.1 MPa, 241 bar)
Standard	243403, B	0.028 in. for wide bead widths	Seam sealing	
Compact	289262, A	0.012 in. for narrow bead widths	Hem flange and after hem	
Compact	289261, A	0.018 in. for medium bead widths	Seam sealing	

PrecisionSwirl Orbital Dispenser Cable Assemblies

Part	Description
233125	6 ft (1.8 m) motor extension cable assembly
233124	9 ft (2.7 m) motor extension cable assembly
233123	15 ft (4.6 m) motor extension cable assembly
617870	55 ft (16.8 m) motor extension cable assembly

Automation Gateway Assemblies

Each control center comes with one automation gateway assembly. The automation gateway module is either a Discrete Gateway Module (DGM) or one of the Communications Gateway Modules (CGM). To order a replacement, see the following table. You will also need to order software upgrade token (16K743).

PCF Model	User Interface Description	Gateway Part Number To Order	Rotary Switch Position
PFxx0x	Discrete (DGM)	24B681	0
PFxx1x	DeviceNet™ (CGM)	15V759	Any
PFxx2x	EtherNet/IP™ (CGM)	15V760	Any
PFxx3x	PROFIBUS™ (CGM)	15V761	Any
PFxx4x	PROFINET™ (CGM)	15V762	Any

Swirl Control DGM

The assemblies below each contain one swirl control DGM used to control one Swirl Dispenser. To order a replacement, see the following table. You will also need to order software upgrade token (16K743).

Assembly	Part Number To Order	Rotary Switch Position
PFxxx2, PFxxx3, 16M350, 16M351	24B681	1, 2, 3, or 4; see Swirl Control DGM on page 19

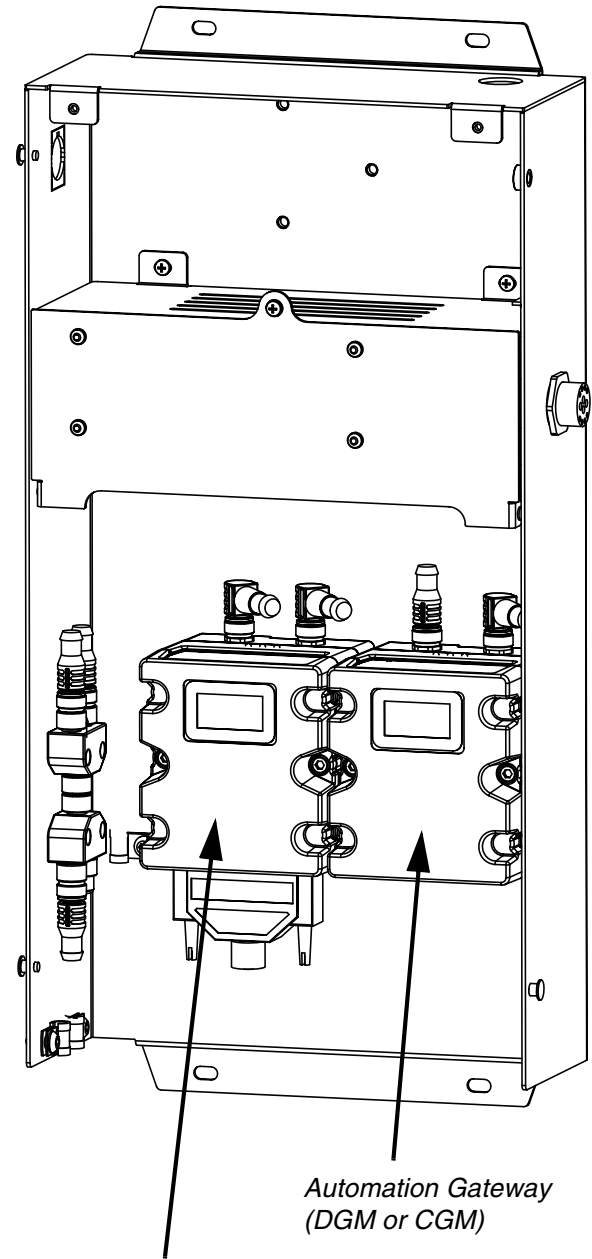



Swirl Control DGM

Automation Gateway
(DGM or CGM)

Warnings

The following warnings are for the setup, use, grounding, maintenance, and repair of this equipment. The exclamation point symbol alerts you to a general warning and the hazard symbols refer to procedure-specific risks. When these symbols appear in the body of this manual, refer back to these Warnings. Product-specific hazard symbols and warnings not covered in this section may appear throughout the body of this manual where applicable.

WARNING

	<p>ELECTRIC SHOCK HAZARD</p> <p>This equipment must be grounded. Improper grounding, setup, or usage of the system can cause electric shock.</p> <ul style="list-style-type: none"> • Turn off and disconnect power at main switch before disconnecting any cables and before servicing or installing equipment. • Connect only to grounded power source. • All electrical wiring must be done by a qualified electrician and comply with all local codes and regulations.
	<p>SKIN INJECTION HAZARD</p> <p>High-pressure fluid from dispensing device, hose leaks, or ruptured components will pierce skin. This may look like just a cut, but it is a serious injury that can result in amputation. Get immediate surgical treatment.</p> <ul style="list-style-type: none"> • Do not point dispensing device at anyone or at any part of the body. • Do not put your hand over the fluid outlet. • Do not stop or deflect leaks with your hand, body, glove, or rag. • Follow the Pressure Relief Procedure when you stop dispensing and before cleaning, checking, or servicing equipment. • Tighten all fluid connections before operating the equipment. • Check hoses and couplings daily. Replace worn or damaged parts immediately
	<p>FIRE AND EXPLOSION HAZARD</p> <p>Flammable fumes, such as solvent and paint fumes, in work area can ignite or explode. To help prevent fire and explosion:</p> <ul style="list-style-type: none"> • Use equipment only in well ventilated area. • Eliminate all ignition sources; such as pilot lights, cigarettes, portable electric lamps, and plastic drop cloths (potential static arc). • Keep work area free of debris, including solvent, rags and gasoline. • Do not plug or unplug power cords, or turn power or light switches on or off when flammable fumes are present. • Ground all equipment in the work area. See Grounding instructions. • Use only grounded hoses. • Hold gun firmly to side of grounded pail when triggering into pail. • If there is static sparking or you feel a shock, stop operation immediately. Do not use equipment until you identify and correct the problem. • Keep a working fire extinguisher in the work area.

WARNING
**EQUIPMENT MISUSE HAZARD**

Misuse can cause death or serious injury.

- Do not operate the unit when fatigued or under the influence of drugs or alcohol.
- Do not exceed the maximum working pressure or temperature rating of the lowest rated system component. See **Technical Data** in all equipment manuals.
- Use fluids and solvents that are compatible with equipment wetted parts. See **Technical Data** in all equipment manuals. Read fluid and solvent manufacturer's warnings. For complete information about your material, request MSDS forms from distributor or retailer.
- Check equipment daily. Repair or replace worn or damaged parts immediately with genuine manufacturer's replacement parts only.
- Do not alter or modify equipment.
- Use equipment only for its intended purpose. Call your distributor for information.
- Route hoses and cables away from traffic areas, sharp edges, moving parts, and hot surfaces.
- Do not kink or over bend hoses or use hoses to pull equipment.
- Keep children and animals away from work area.
- Comply with all applicable safety regulations.

**BURN HAZARD**

Equipment surfaces and fluid that's heated can become very hot during operation. To avoid severe burns:

- Do not touch hot fluid or equipment.

**TOXIC FLUID OR FUMES HAZARD**

Toxic fluids or fumes can cause serious injury or death if splashed in the eyes or on skin, inhaled, or swallowed.

- Read MSDS's to know the specific hazards of the fluids you are using.
- Store hazardous fluid in approved containers, and dispose of it according to applicable guidelines.

**PERSONAL PROTECTIVE EQUIPMENT**

You must wear appropriate protective equipment when operating, servicing, or when in the operating area of the equipment to help protect you from serious injury, including eye injury, hearing loss, inhalation of toxic fumes, and burns. This equipment includes but is not limited to:

- Protective eyewear, and hearing protection.
- Respirators, protective clothing, and gloves as recommended by the fluid and solvent manufacturer

System Configurations

Typical Installation - Single Swirl, Single Fluid Plate

NOTE: Shown with one fluid plate and one swirl dispenser.

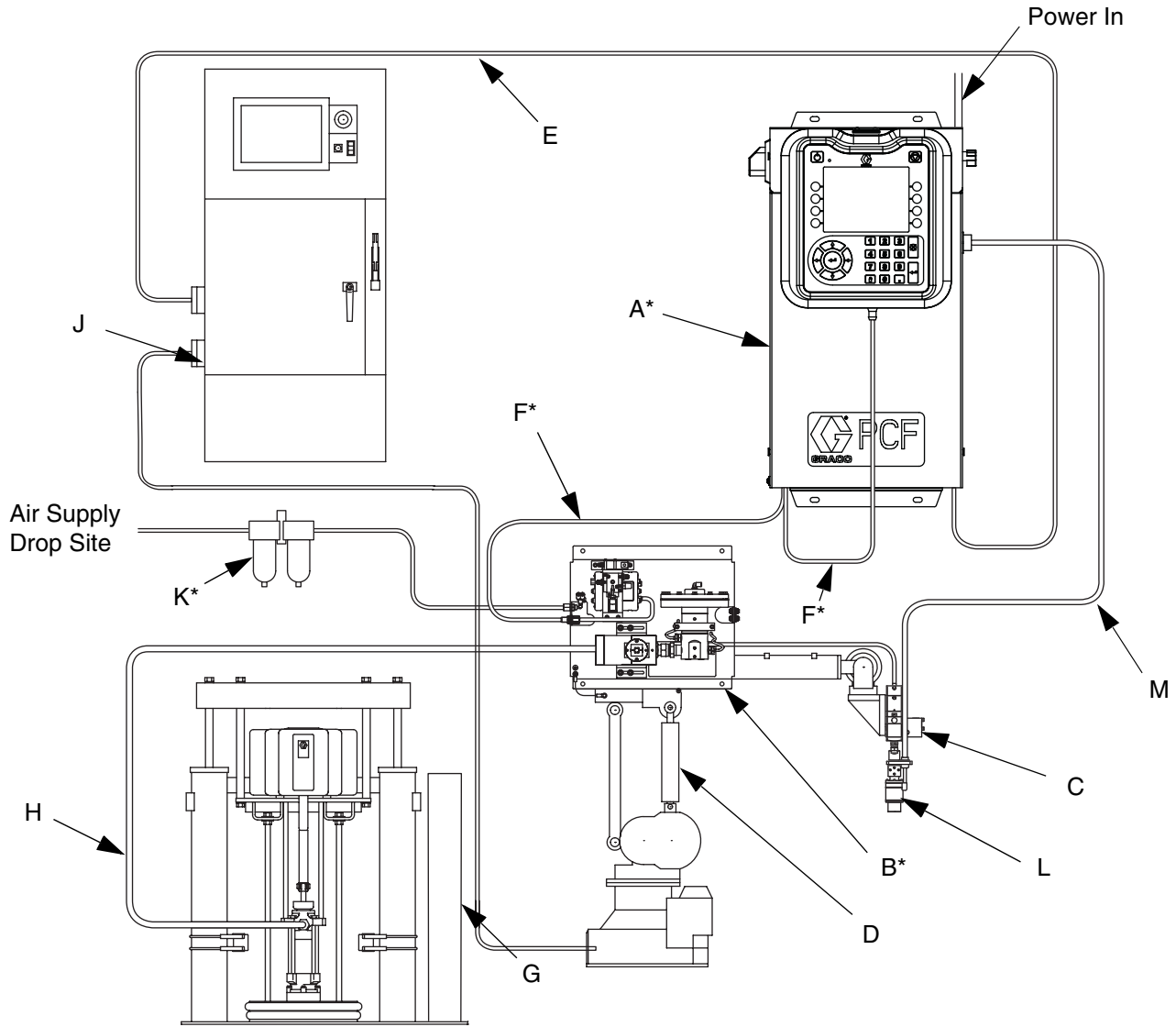

FIG. 1: Typical Ambient System Installation

- Key:**
- | | |
|------------------------------------|---|
| A *Control Center (User Interface) | H Fluid Supply Hose |
| B *Fluid Plate Assembly | J Automation Controller |
| C Applicator/Dispense Valve | K *Air Filter Assembly |
| D Sealer Automation | L ◆PrecisionSwirl Orbital Dispenser (Swirl Dispenser) |
| E Automation Interface Cable | M ◆PrecisionSwirl Cable |
| F *CAN Cable | |
| G Fluid Supply System | |
- * Included
 ◆ Optional

Typical Installation - Multiple Fluid Plates, No Swirl Dispensers

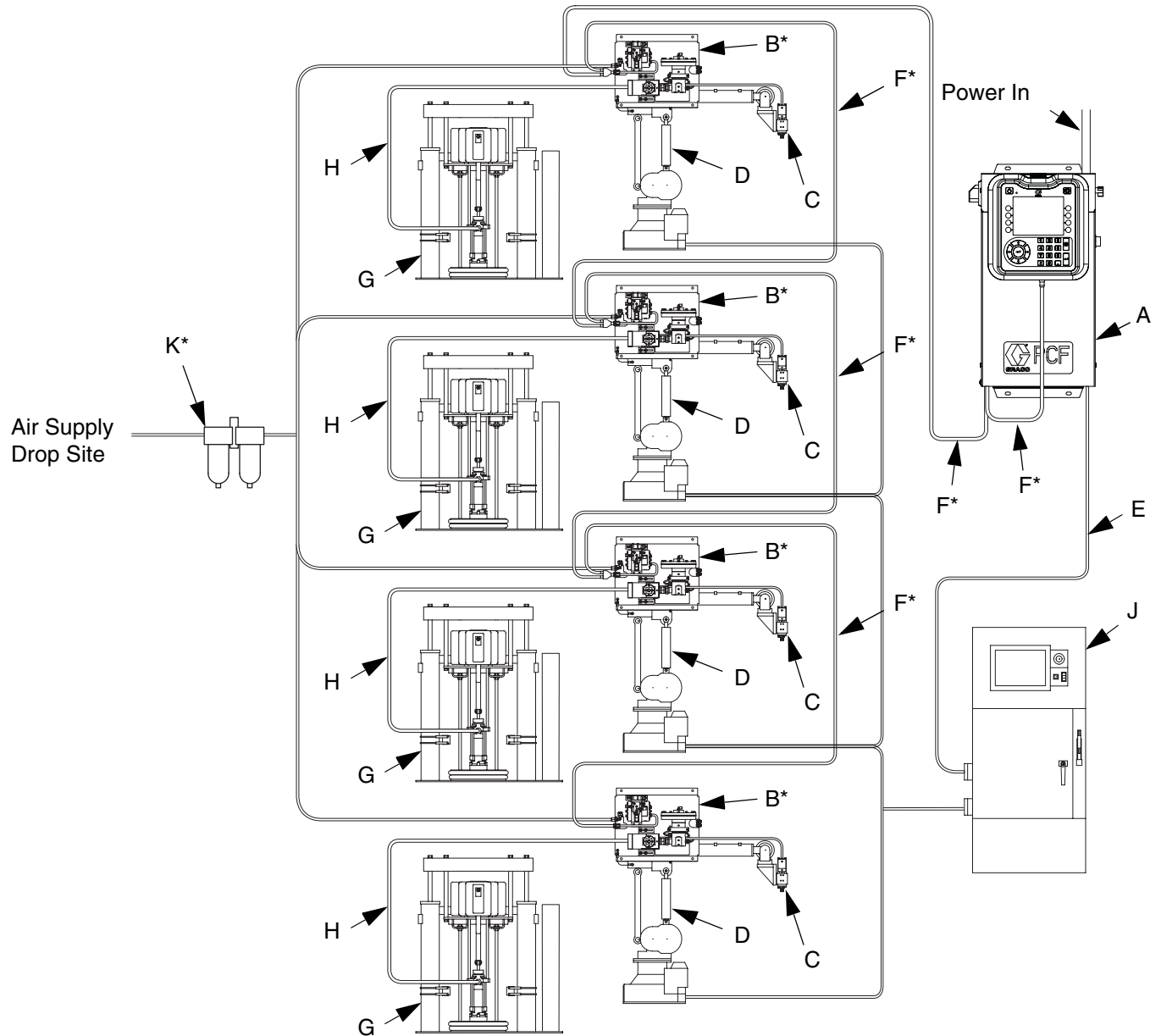

FIG. 2: Typical Multiple Fluid Plate System Installation

Key:

- A *Control Center (User Interface)
- B *Fluid Plate Assembly
- C Applicator/Dispense Valve
- D Sealer Automation
- E Automation Interface Cable

- F *CAN Cable
- G Fluid Supply System
- H Fluid Supply Hose
- J Automation Controller
- K *Air Filter Assembly

* Included

Typical Installation - Multiple Fluid Plates, Multiple Swirl Dispensers

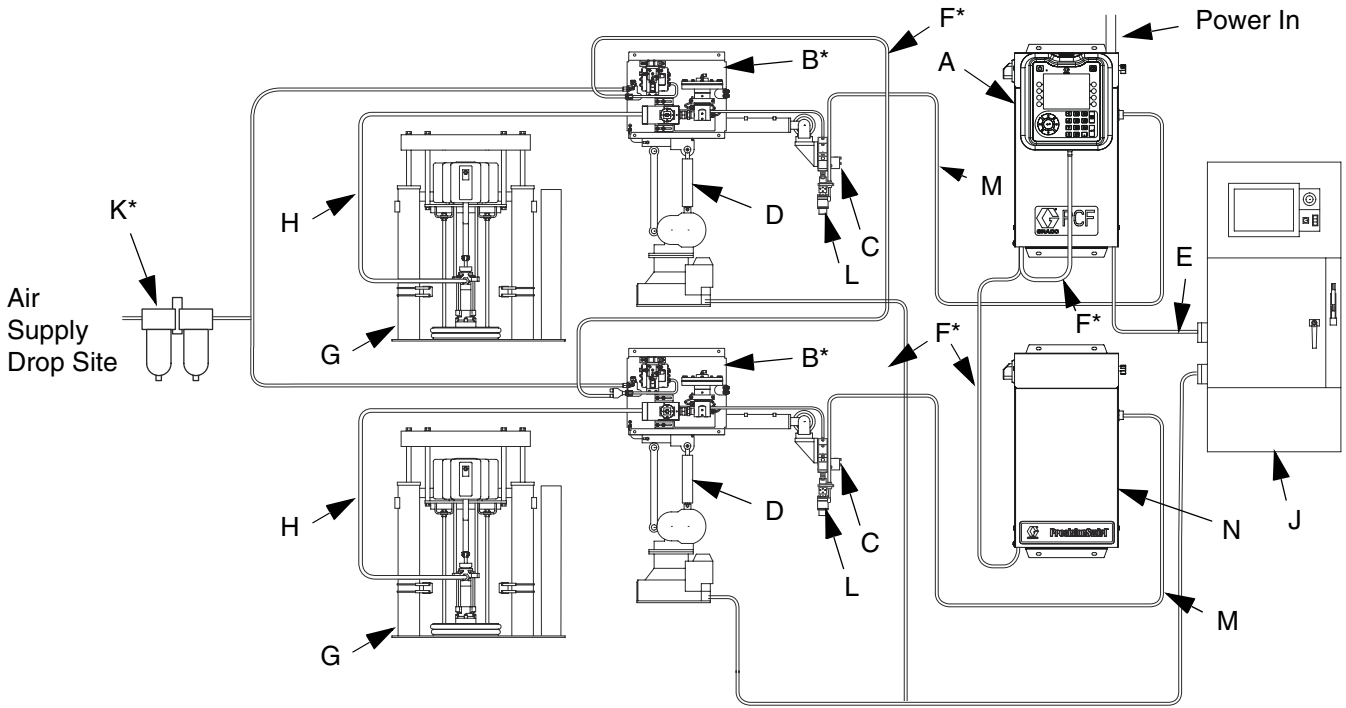

Fig. 3: Typical Multiple Fluid Plate System Installation

Key:

- A *Control Center (User Interface)
- B *Fluid Plate Assembly
- C Applicator/Dispense Valve
- D Sealer Automation
- E Automation Interface Cable
- F *CAN Cable
- G Fluid Supply System
- H Fluid Supply Hose
- J Automation Controller
- K *Air Filter Assembly
- L ◆PrecisionSwirl Orbital Dispenser (Swirl Dispenser)
- M ◆PrecisionSwirl Cable
- N ◆Expansion Swirl Enclosure

- * Included
- ◆ Optional

Overview

System Overview

The PCF fluid metering system combines closed-loop pressure control with the ability to change bead profiles quickly. When used with an optional flow meter, the system automatically adjusts for fluctuations in the operating environment, such as material viscosity, temperature and tip wear, in order to maintain the desired dispense rate. The module responds to automation signals to provide an accurate and consistent output flow based on a comparison of actual to desired flow rates.

Typical Applications

- Bead dispensing
- Gasketing
- Seam sealing
- Hem flange
- Sound deadening
- Anti-flutter
- Body panel reinforcement
- Profile wrapping
- Cable filling

System Components

The diagram in FIG. 4 shows an example of the PCF module and cables.

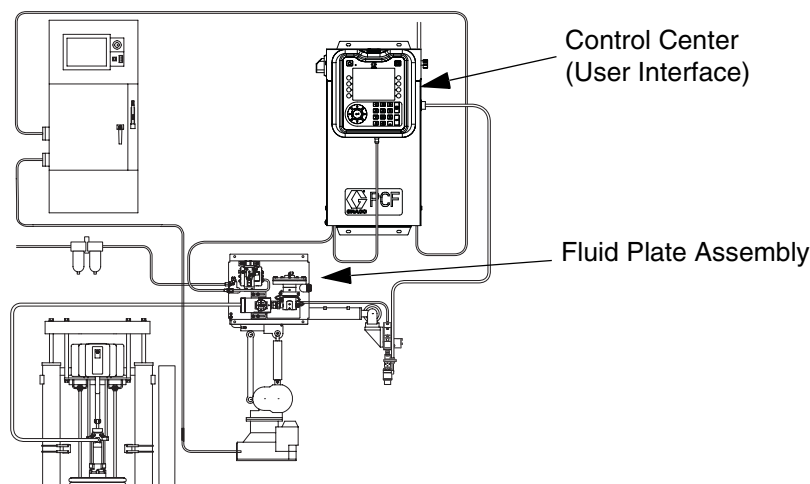

System shown with one fluid plate and one swirl dispenser

FIG. 4: PCF System Components

Control Center (User Interface)

The control center communicates with the PCF fluid plate assembly to control fluid pressure and dispense valve operation.

The control center receives input from the automation controller, and uses these inputs to determine communication to the fluid plate assembly.

Fluid Plate Assembly

The fluid plate assembly contains components that control and monitor fluid dispensing. A PCF fluid metering system can have up to four fluid plates. Each fluid plate can control up to four dispense valves. The system supports up to 16 dispense valves and can simultaneously dispense from up to 10 dispense valves.

PrecisionSwirl Orbital Dispenser (Swirl Dispenser), Sold Separately

The swirl dispenser dispenses material in a circular pattern at speeds from 6600 to 24000 rpm. A PCF fluid metering system can have up to four swirl dispensers. See manual 309403 for detailed information.

Fluid Plate Assembly Overview

Fluid Plate Components

The fluid plate assembly in FIG. 5 can be attached to an automation arm or mounted on a pedestal. The main components of the fluid plate assembly include:

- Fluid regulator (cartridge, ambient mastic, or heated mastic) (P).
- Flow meter (R) (optional) precisely measures the flow rate of fluid dispensed.
- Solenoid air valve (S) controls the dispense valve.
- Voltage to Pressure Transducer (T), abbreviated V/P transducer, adjusts the air pressure to the fluid regulator (P).
- Fluid Control Module (FCM) (U) receives pulse readings from the flow meter (R) and pressure readings from the regulator. It also controls the fluid regulator (P) and solenoid air valve (S).

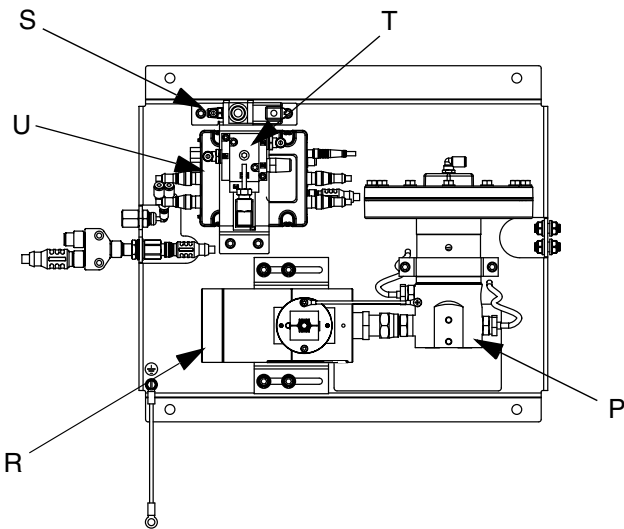

FIG. 5: Fluid Plate Components

The PCF fluid regulator is electrically controlled by the PCF fluid control module. Consistent material flow is assured by a closed-loop pressure or closed-loop flow control design. The module responds to automation-supplied signals to provide an accurate and consistent output flow based on a comparison of actual to desired flow rates. The fluid regulator uses air pressure to control fluid pressure and to provide fast response to electronic commands and ensure a precisely controlled, continuous flow of material.

The fluid plate assembly is available in two versions: ambient and heated.

Ambient Fluid Plate Assembly

There are four ambient versions available:

- cartridge regulator without a flow meter;
- ambient mastic regulator without a flow meter;
- cartridge regulator with a high resolution meter;
- ambient mastic regulator with a high resolution meter;
- cartridge regulator with an ultra high resolution flow meter.

Heated Fluid Plate Assembly

There are two heated versions available:

- heated mastic fluid regulator with a heated flow meter,
- and a heated mastic fluid regulator without a flow meter.

Fluid Regulator

There are three fluid regulator options:

- cartridge
- ambient mastic
- heated mastic

All of the fluid regulator options use air pressure to control fluid pressure, provide fast response to electronic commands, and ensure a precisely controlled, continuous flow of material.

Cartridge

The cartridge regulator (244734) is ideal for low to medium viscosity sealants and adhesives.

Ambient Mastic

The ambient mastic regulator (246642) is ideal for medium to high viscosity sealants and adhesives.

Heated Mastic

The heated mastic regulator (246643) is ideal for low to high viscosity warm-melt and hot-melt sealants or adhesives.

Fluid Control Module (FCM)

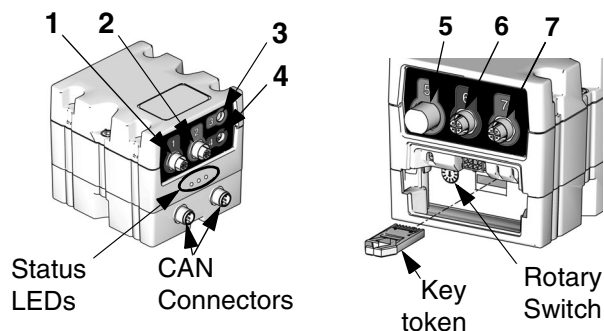

FIG. 6: FCM Sensor Connections

Table 1: FCM Sensor Connections

Connection	Sensor Description
1	Dispense solenoid
2	Flow meter
3	Outlet pressure sensor (heated systems only)
4	Voltage to Pressure (V/P) Transducer
5	Command cable (optional accessory kit)
6	Inlet pressure sensor (non-heated systems only)
7	Outlet pressure sensor (non-heated systems only)
CAN Connectors	---

Rotary Switch on FCM

The rotary switch on the FCM, see FIG. 6, must be set to a valid position and each FCM must have a unique rotary switch position. The FCM rotary switch position determines which number to assign to that fluid plate. The settings, including defined styles, for each fluid plate are stored in each FCM so changing the rotary switch position causes the settings to be shown under the new number on the ADM.

Item	Rotary Switch Position
Fluid Plate 1	0 or 1
Fluid Plate 2	2
Fluid Plate 3	3
Fluid Plate 4	4

NOTE: See **LED Diagnostic Information**, page 65, for signal definitions.

Control Center Assembly Overview

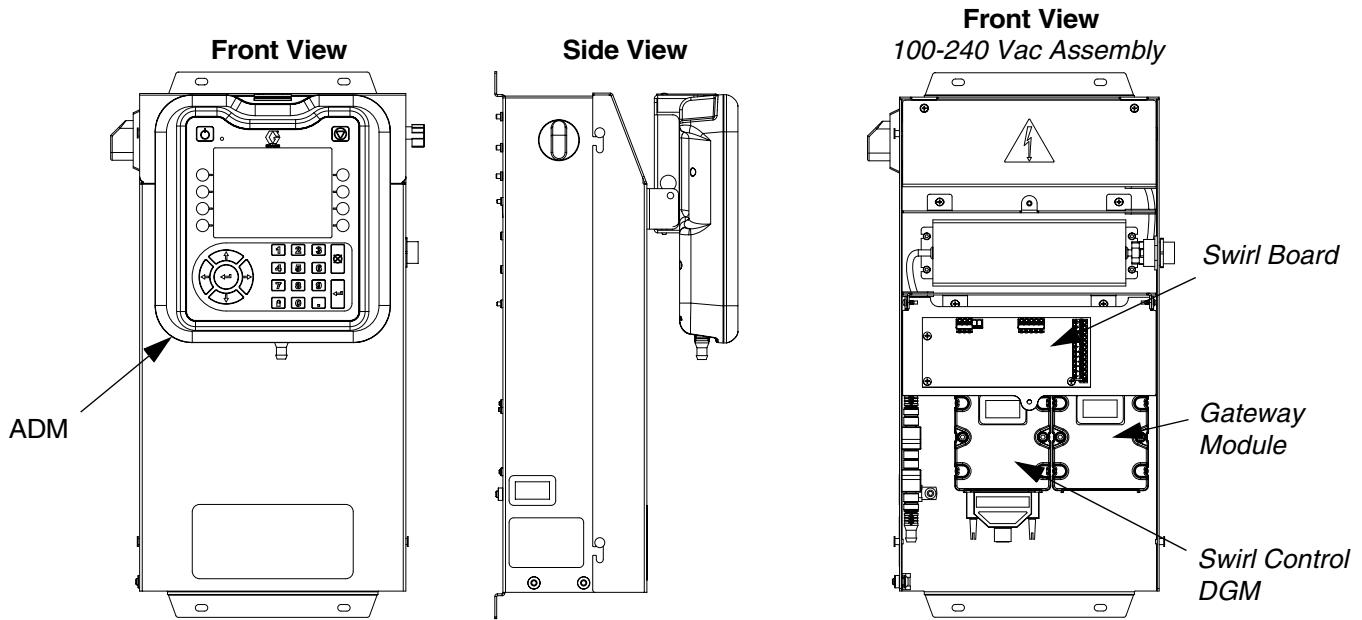

FIG. 7: Control Center Components

The control center includes the following components:

- Advanced Display Module (ADM) with USB; see page 17 for details.
- USB enables users to download job, event, and data logs; save and restore system settings; and customize the language. See **USB Data** on page 59.
- 24 Vdc and 100-240 Vac customer-wired options available.
- *If system has a swirl dispenser:* Swirl Control DGM (the module on the left) and Swirl Board.
- Automation Gateway Module (the module on the right), which can be one of the following five types:
 - Discrete
 - DeviceNet
 - EtherNet/IP
 - PROFIBUS
 - PROFINET

Expansion Swirl Enclosure

If more than one swirl dispenser is installed, the system will have one Expansion Swirl Enclosure for each additional swirl dispenser. The Expansion Swirl Enclosure is similar to the primary control center, but it does not include the ADM or the Automation Gateway module.

Advanced Display Module (ADM)

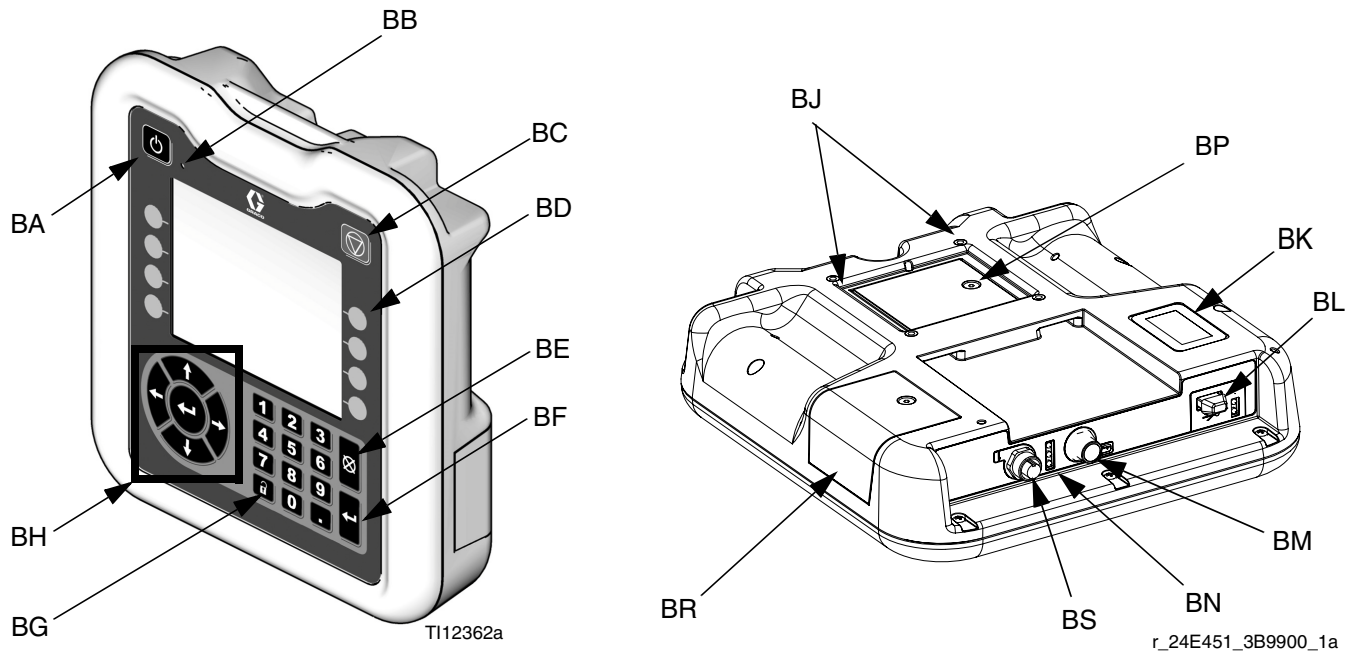

FIG. 8: Advanced Display Module Component Identification

KEY:

Callout	Function
BA	Power On/Off Button Enables/disables system.
BB	System Status Indicator LED Displays system status. Green LED indicates the system is active. Orange LED indicates the system is off. Solid LEDs (green or orange) indicate the system is in Run mode. Flashing LEDs (green or orange) indicate the system is in Setup mode.
BC	Stop Button Stops all system processes. However, it is not a safety or emergency stop.
BD	Soft Keys Functions vary depending on the screen.
BE	Cancel Button Clears system errors and cancels a selection or number entry while in the process of entering a number or making a selection.
BF	Enter Button Acknowledge changing a value or making a selection.
BG	Lock/Setup Toggle between run and setup screens. If setup screens are password protected, button toggles between run and password entry screens.

Callout	Function
BH	Navigation Buttons Navigate within a screen or to a new screen.
BJ	Flat Panel Mount Mounts to control center bracket (optional).
BK	Model Number Tag Model number.
BL	USB Module Interface USB port and USB indicator LEDs.
BM	CAN Connector Power connection.
BN	Module Status LEDs See LED Diagnostic Information , page 65, for signal definitions.
BP	Battery Cover
BR	Token Access Cover
BS	Digital I/O Port for Light Tower

NOTICE

To prevent damage to the soft key buttons, do not press the buttons with sharp objects such as pens, plastic cards, or fingernails.

Automation Gateway Module

See the following table for the appropriate rotary switch position for your automation gateway module.

PCF Model	User Interface Description	Gateway Part Number To Order	Rotary Switch Position
PFxx0x	Discrete (DGM)	24B681	0
PFxx1x	DeviceNet™ (CGM)	15V759	Any
PFxx2x	EtherNet/IP™ (CGM)	15V760	Any
PFxx3x	PROFIBUS™ (CGM)	15V761	Any
PFxx4x	PROFINET™ (CGM)	15V762	Any

NOTE: See **Control Center Assembly Overview** on page 16 for automation and swirl control DGM identification.

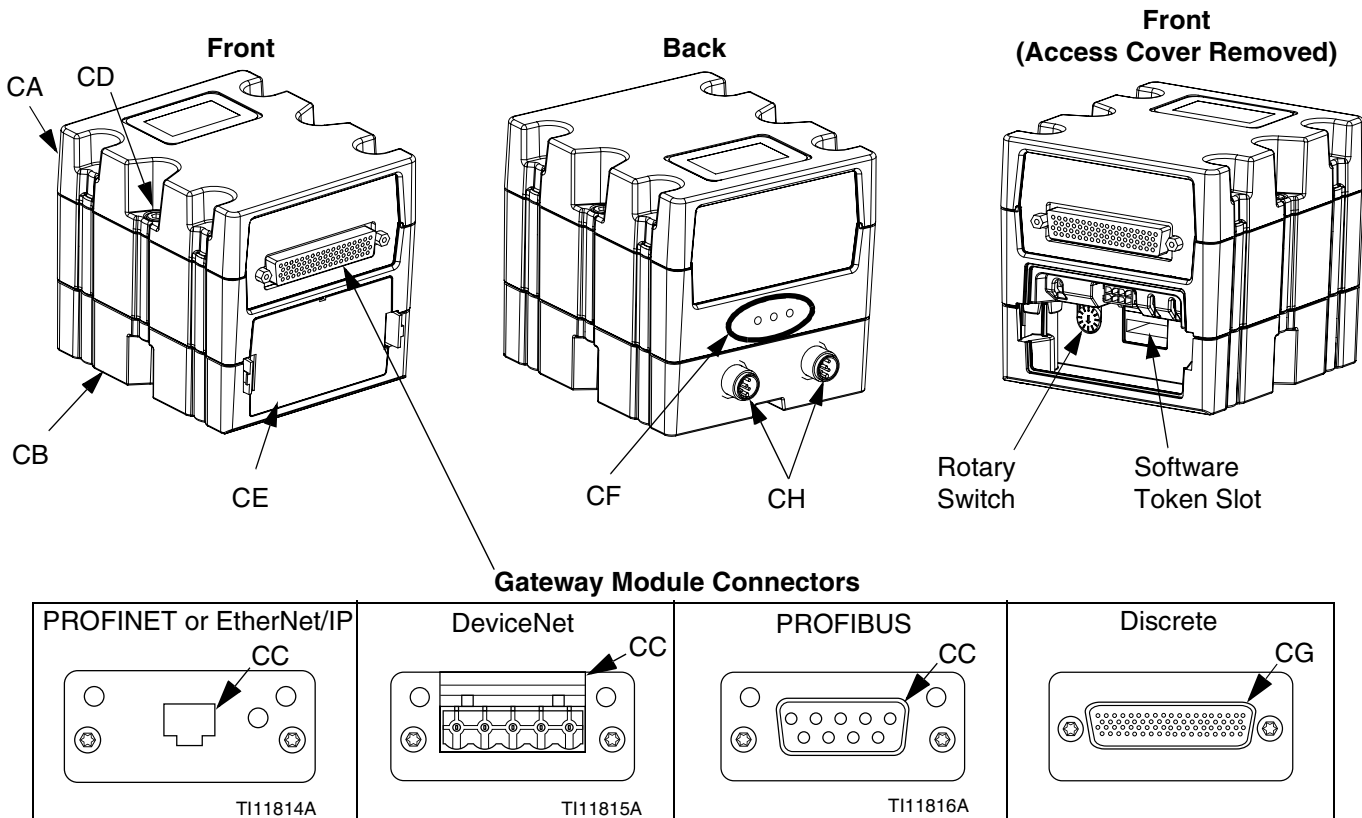

FIG. 9: Automation Gateway Module Components

Key:

- CA Gateway Module
- CB Base
- CC Fieldbus Connector (see **Appendix C - Communications Gateway Module (CGM) Connection Details**, page 122, for more information)
- CD Module Connection Screws
- CE Access Cover
- CF Module Status LEDs (see **LED Diagnostic Information**, page 65)

- CG D-Subminiature (D-Sub) Connector (see **Appendix B - Discrete Gateway Module (DGM) Connection Details**, page 115, for pinout details)
- CH CAN Connectors

Swirl Control DGM

One swirl control DGM is included in the integrated Swirl control center, and in each expansion swirl enclosure. Each Swirl control DGM controls one swirl orbiter.

Each swirl control DGM must have a unique rotary switch position. The rotary switch position determines the number assigned to the swirl dispenser attached to that DGM. If the rotary switch position must be changed, do so with the power off.

DGM Function	Rotary Switch Position
Swirl Control 1	1
Swirl Control 2	2
Swirl Control 3	3
Swirl Control 4	4

Each integrated swirl control center and swirl enclosure comes with a pre-installed cable between the swirl control DGM and the swirl board. The customer does not need to make any external connections with the swirl control DGM.

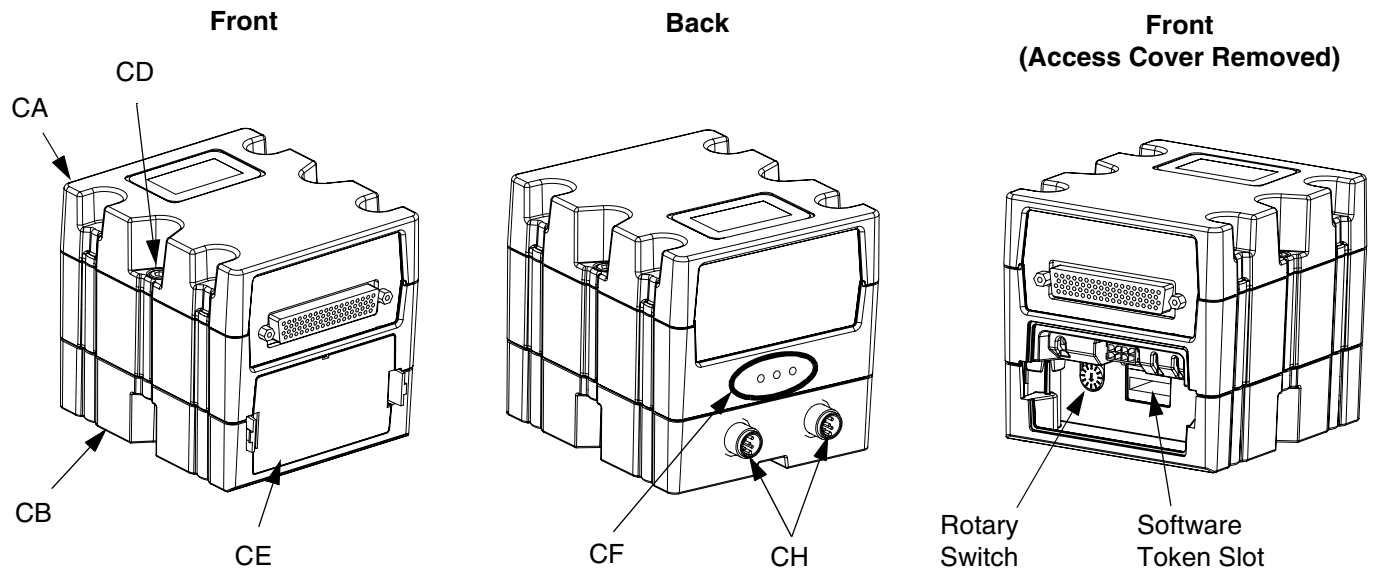

FIG. 10: Swirl Control DGM

Key Tokens

The ADM and FCM must each have a key token installed in order to operate. If the incorrect key token is installed, the module will not operate. The DGM does not require a key token.

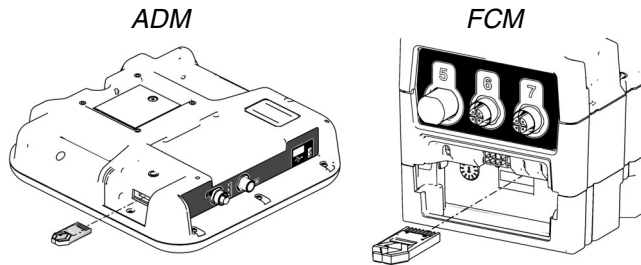

FIG. 11

NOTE: There is one FCM located on each fluid plate.

If a new ADM or FCM is installed, follow the instructions on page 77 to upgrade the software in the new module and to install the key token from the old module in the new module.

The following is a list of key token part numbers. If you lose your key token be sure to order the correct item to ensure proper system operation.

NOTE: The key tokens for the ADM and FCM look alike but only work in one module or the other. If the key tokens for the ADM and FCM become mixed, locate the part number on each token then refer to the following table to determine which module each token applies to.

Part	Description
16M100	FCM Key Token, 2 styles, Flow Meter
16M101	FCM Key Token, 2 styles, No Flow Meter
16M102	FCM Key Token, 16 styles, Flow Meter
16M103	FCM Key Token, 16 styles, No Flow Meter
16M104	FCM Key Token, 256 styles, Flow Meter
16M105	FCM Key Token, 256 styles, No Flow Meter
16M217	ADM Key Token, Standard PCF

Installation

Before Installation

- Have all system and component documentation available during installation.
- See component manuals for specific data on component requirements. Data presented here applies to the PCF assemblies only.
- Be sure all accessories are adequately sized and pressure-rated to meet system requirements.
- Use the PCF control center only with the PCF fluid plate assembly.

10. Connect other fluid and air lines to additional system components as instructed in their manuals.
11. Install fluid plate, swirl, and gateway cable assemblies, page 28.
12. Install Gateway interface, page 30.

Overview

The basic steps to install a PCF system are shown below. See the separate component manuals for detailed information.

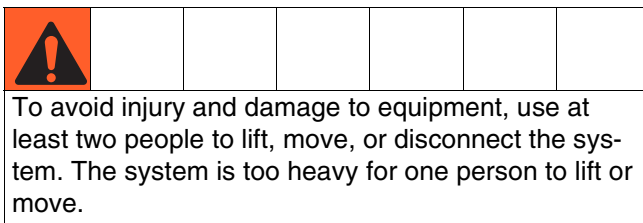

Installation Steps

1. Mount control center, page 22.
2. *For systems with multiple swirl dispensers*, mount expansion Swirl enclosures, page 22.
3. Connect and ground control center and expansion Swirl enclosures, page 23.
4. Mount each fluid plate assembly, page 24.
5. Ground each fluid plate assembly, page 27.
6. Check ground continuity.
7. Connect fluid lines between each fluid plate and applicator. Connect fluid supply line and air supply to module. See page 27.
8. Plumb air filter assembly near air supply drop site that will be used for fluid plate assembly.
9. *For systems with swirl dispensers*, install each swirl dispenser onto outlet of a dispense valve.

Install Control Center

NOTE: This section applies to both the primary control center and the expansion Swirl enclosures.

Mount

Ensure the following criteria are met before mounting the PCF control center:

- Select a location for the control center that allows adequate space for installation, service, and use of the equipment.
- For best viewing, the ADM should be 60-64 in. (152-163 cm) from the floor.
- Ensure there is sufficient clearance around the control unit to run cables to other components.
- Ensure there is safe and easy access to an appropriate electrical power source. The National Electric Code requires 3 ft (0.91 m) of open space in front of the control center.
- Ensure there is easy access to the power switch.
- Ensure the mounting surface can support the weight of the control center and the cables attached to it.

Secure the control center with appropriate size bolts through the 0.27 in. (7 mm) diameter holes in the mounting tabs. See the following mounting dimensions.

Table 2: Control Center Assembly Measurement

A	10.50 in. (267 mm)
B	5.75 in. (146 mm)
C	22.00 in. (559 mm)
D	21.25 in. (540 mm)

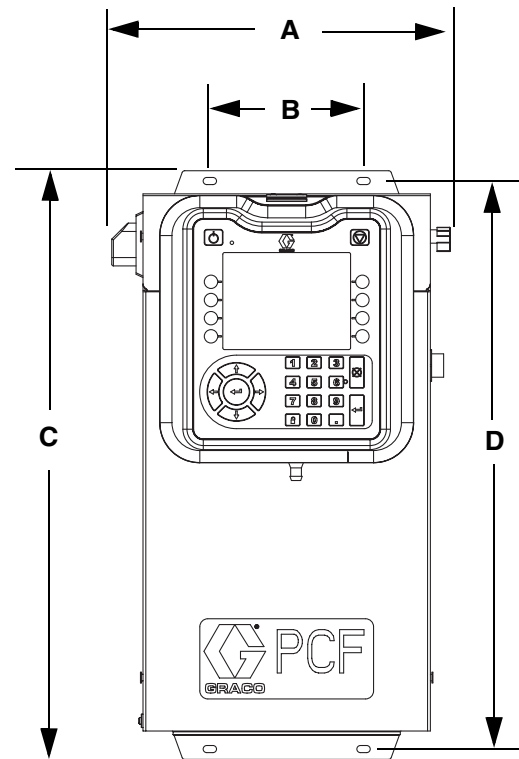

FIG. 12: Control Center Dimensions

Electrical Connections



To reduce the risk of fire, explosion, or electric shock, when grounding, connecting cables, connecting to a power source or making other electrical connections:

- The control center must be electrically connected to a true earth ground; the ground in the electrical system may not be sufficient. Refer to your local code for the requirements for a “true earth ground” in your area.
- All wires used for grounding must be 18 AWG minimum.
- A qualified electrician must complete all grounding and wiring connections.
- For 24 Vdc wiring refer to FIG. 13.
- For 100-240 Vac wiring refer to FIG. 14.
- Incoming power wiring must be guarded from the enclosure. Use a protective grommet where the power wiring enters the enclosure to prevent wear.

NOTICE

If power and grounding connections are not done properly, the equipment will be damaged and the warranty voided.

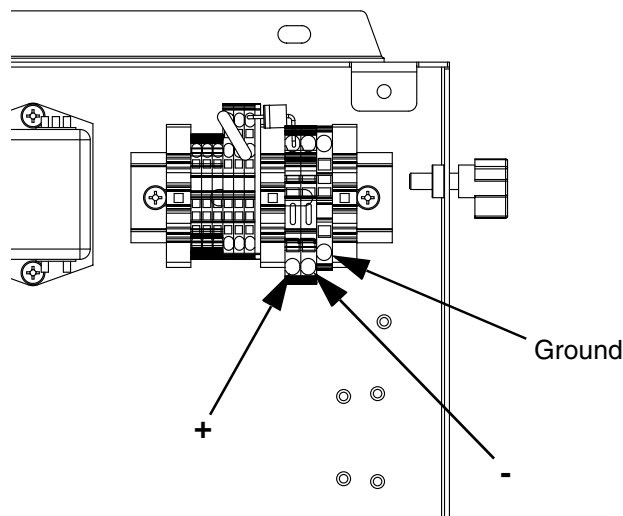

FIG. 13: 24 Vdc Wiring

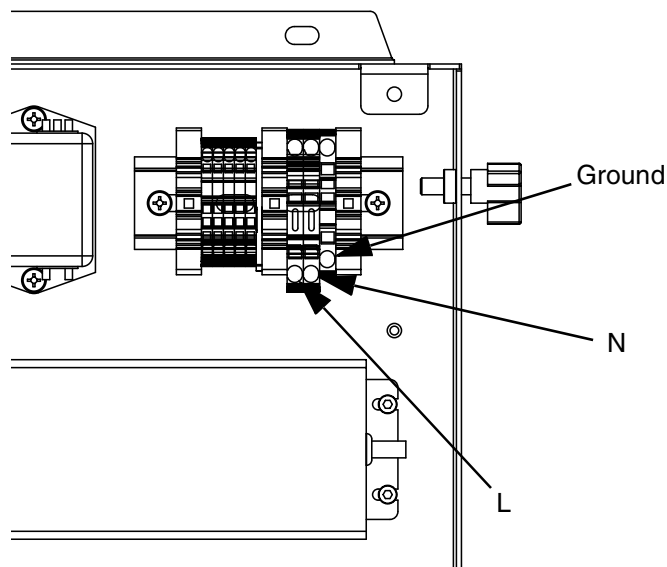

FIG. 14: 100-240 Vac Wiring

Connect Light Tower Accessory

1. Order the 255468 Light Tower Accessory as a diagnostic indicator for the PCF system.
2. Connect the cable from the light tower to the digital I/O port (BS) on the ADM.

See Table 3 for a description of light tower signals.

Table 3: Light Tower Signals

Signal	Description
Green	No errors.
Yellow	An advisory exists.
Yellow flashing	A deviation exists.
Red solid	An alarm exists. One or more fluid plates may be shutdown.

NOTE: See **Errors**, page 66, for error definitions.

Install Fluid Plate Assemblies

To install the PCF fluid plate assemblies:

- Mount the fluid plate assemblies, page 24
- Ground fluid plate assemblies, page 27
- Connect one fluid plate assembly to the control center. See **Install Cable Assemblies** on page 28.
- *If multiple fluid plates*, connect the fluid plates together. See **Install Cable Assemblies** on page 28.
- Connect fluid lines, air lines, and cables; page 27

Mount

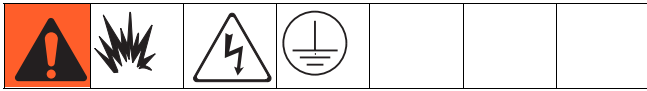

Before Mounting Assembly

- See component manuals for specific information on component requirements. Information presented here pertains to the PCF fluid plate assembly only.
- Have all system and subassembly documentation available during installation.
- Be sure all accessories are adequately sized and pressure-rated to meet the system's requirements.
- Use only the Graco PCF fluid plate assembly with the Graco PCF control center.

Mount Assembly

1. Select a location for the fluid plate assembly. Keep the following in mind:
 - Allow sufficient space for installing the equipment.
 - Make sure all fluid lines, cables and hoses easily reach the components to which they will be connected.
 - Make sure the fluid plate assembly allows the automation unit to move freely along all axis.
 - Make sure the fluid plate assembly provides easy access for servicing its components.

2. Mount and secure the fluid plate assembly to the automation unit (or other mounting surface) with appropriate size bolts through the 0.397 in. (10 mm) diameter holes in the base plate. See the mounting dimensions in Table 4 and FIG. 15.

Table 4: Fluid Plate Assembly Measurement

A	16.5 in. (419 mm)
B	14.0 in. (356 mm)
C	14.4 in. (366 mm)
D	13.4 in. (340 mm)

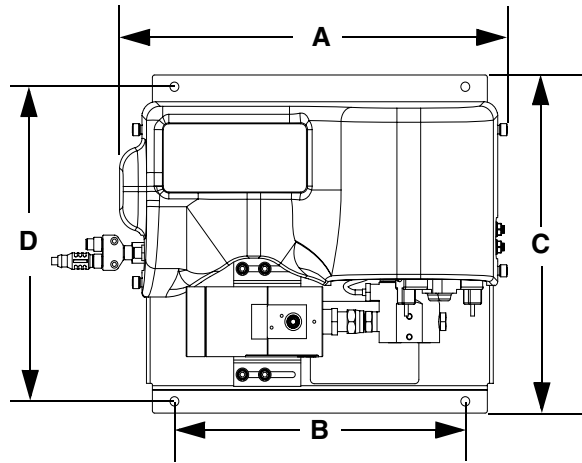

FIG. 15: Fluid Plate Assembly Dimensions

Mount Four-Valve Breakout Kit 24B693

PCF is capable of controlling up to four separate dispense valves from port 1 on the FCM. A four-valve breakout kit (24B693) is available to split the dispense solenoid connector (port 1 on the FCM) into four separate dispense solenoid connectors. For each additional dispense valve, order one dispense valve solenoid (258334) and one solenoid cable (121806).

Follow this procedure if using the four-valve breakout kit.

1. Remove the existing dispense solenoid and cable from the fluid plate.
2. Install bulkhead fitting (included in the kit) into the empty hole on the fluid plate.

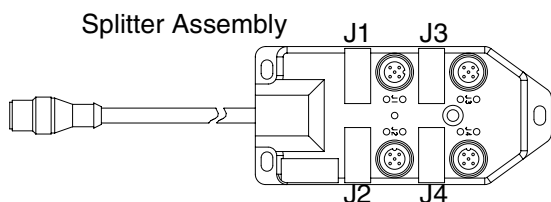
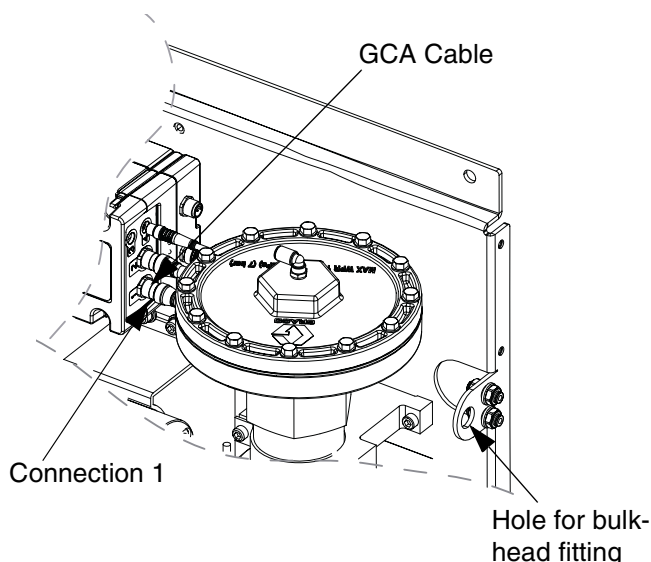

FIG. 16: Mount Breakout Kit

3. Connect one end of the extension cables (included in the kit) to connection 1 on the FCM and the other end of the cable to the bulkhead fitting.
4. Connect the splitter assembly to the bulkhead fitting.

5. Connect the dispense valve cable(s) to the connections on the splitter assembly.

Cable for:	Connects to Splitter Connection Labeled:
Dispense Valve 1	J1
Dispense Valve 2	J2
Dispense Valve 3	J3
Dispense Valve 4	J4

6. Mount splitter assembly and dispense valves, and connect air lines as necessary for application.

Custom Breakout Cable

If desired, the following connector pinout information may be used to build a custom breakout cable:

Pinout of FCM Port 1

- Pin 1: Dispense Solenoid 4
- Pin 2: Dispense Solenoid 2
- Pin 3: Voltage - (common for all solenoids)
- Pin 4: Dispense Solenoid 1
- Pin 5: Dispense Solenoid 3

Dispense solenoid outputs are 24 Vdc. Dispense solenoid outputs are capable of sourcing up to 0.5A each (maximum 12W coil).

Install Command Cable Kit 24B694

Follow this procedure if using the command cable kit.

1. Install bulkhead fitting (included in the kit) into the empty hole on the fluid plate. See FIG. 16 on page 25.
2. Connect one end of the extension cable (included in the kit) to connection 5 on the FCM and the other end of the cable to the bulkhead fitting.
3. Connect command cable to bulkhead fitting and wire to automation controller per the following pinout table.

FCM Port Pin #	Command Cable Wire Color	Function	
		Dispense Trigger Source: 'Command Cable' or 'Combined'	Dispense Trigger Source: 'Command Cable 3x'
1	White	Command voltage (0-10 Vdc)	Command voltage (0-10 Vdc)
2	Brown	No connection	Valve 3 dispense trigger (*sourcing input)
3	Green	Dispense trigger (*sourcing input)	Valve 1 dispense trigger (*sourcing input)
4	Yellow	No connection	Valve 2 dispense trigger (*sourcing input)
5	Gray	Dispense trigger ground	Dispense trigger ground
6	Pink	No connection	No connection
7	Blue	Command signal ground	Command signal ground
8	Red	No connection	No connection

NOTE: Command cable inputs are not isolated from PCF 24 Vdc power.

* *To turn on the dispense trigger, connect the dispense trigger pin to the dispense trigger ground pin (pin 5).*

Ground

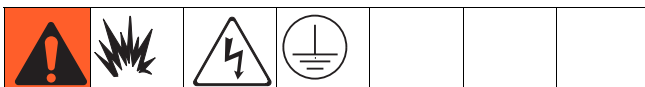

To reduce the risk of fire, explosion, or electric shock, when grounding, connecting cables, connecting to a power source or making other electrical connections:

- The control center must be electrically connected to a true earth ground; the ground in the electrical system may not be sufficient. Refer to your local code for the requirements for a “true earth ground” in your area.
- All wires used for grounding must be 18 AWG minimum.
- A qualified electrician must complete all grounding and wiring connections.
- For 24 Vdc wiring refer to FIG. 13.
- For 100-240 Vac wiring refer to FIG. 14.
- Incoming power wiring must be guarded from the enclosure. Use a protective grommet where the power wiring enters the enclosure to prevent wear.

NOTICE

If power and grounding connections are not done properly, the equipment will be damaged and the warranty voided.

Ground the fluid plate assembly as instructed here and in the individual component manuals. Make sure the fluid plate assembly and its components are installed correctly to ensure proper grounding.

Air and Fluid Hoses

For static dissipation, use only electrically conductive hoses or ground the applicator / dispense valves.

Dispense Valve

Follow the grounding instructions in the dispense valve manual.

Connect Fluid and Air Lines

NOTICE

Route all fluid and air lines carefully. Avoid pinching and premature wear due to excessive flexing or rubbing. Hose life is directly related to how well they are supported.

Follow the instructions in your separate component manuals to connect air and fluid lines. The following are only general guidelines.

- The PCF fluid plate assembly should be installed on the automation unit or in another appropriate place, as close as practical to the dispense valve.
- Connect a fluid line between the fluid plate outlet and the dispense valve. Smaller diameter and shorter fluid lines (hoses) will provide better fluid system response.
- Connect a fluid line to the flow meter fluid inlet or to the regulator inlet if your system does not have a flow meter.
- Air must be clean and dry, between 60-120 psi (0.41-0.82 MPa, 4.14-8.27 bar). Flush air line before plumbing in air filter assembly (234967). Plumb in air filter assembly near air drop site (upstream of fluid plate module). Adding an air regulator to this line will provide more consistent dispense valve response times.
- Connect an air supply line to the 1/4 npt inlet port on the fluid plate(s) air supply inlet.
- Connect 5/32 in. or 4 mm OD air lines from the applicator's solenoid valve to the applicator. Plug any unused solenoid ports.

NOTE: To maximize system performance keep the dispense hose length and ID as small as the application will allow.

Install Cable Assemblies

NOTE: To prevent system errors, only connect cables with the power off.

NOTE: See FIG. 17 on page 29.

1. *For systems with more than one swirl dispenser:*
Use a CAN cable to connect the control center to one swirl expansion enclosure. Use additional CAN cables to connect any remaining expansion swirl enclosures together in sequence.
2. *For systems with one or more swirl dispensers,* use motor cable to connect each swirl dispenser to an expansion swirl enclosure or to the control center.
3. Connect a CAN cable from the control center to one fluid plate assembly.
4. *For multiple fluid plate systems,* use CAN cables to connect each fluid plate to one other fluid plate. Repeat until all fluid plates are connected to one other fluid plate.

NOTE: Use the connections on the CAN splitter on the left side of each fluid plate to connect the fluid plates together. There will be a CAN splitter on all but one fluid plate.

NOTE: The control center, expansion swirl enclosures, and fluid plates may be connected in any order as long as each is connected to another system component with a CAN cable. See the example shown in FIG. 17 on page 29.

5. Use the automation interface cable (not provided) to connect the Gateway module to the automation controller.

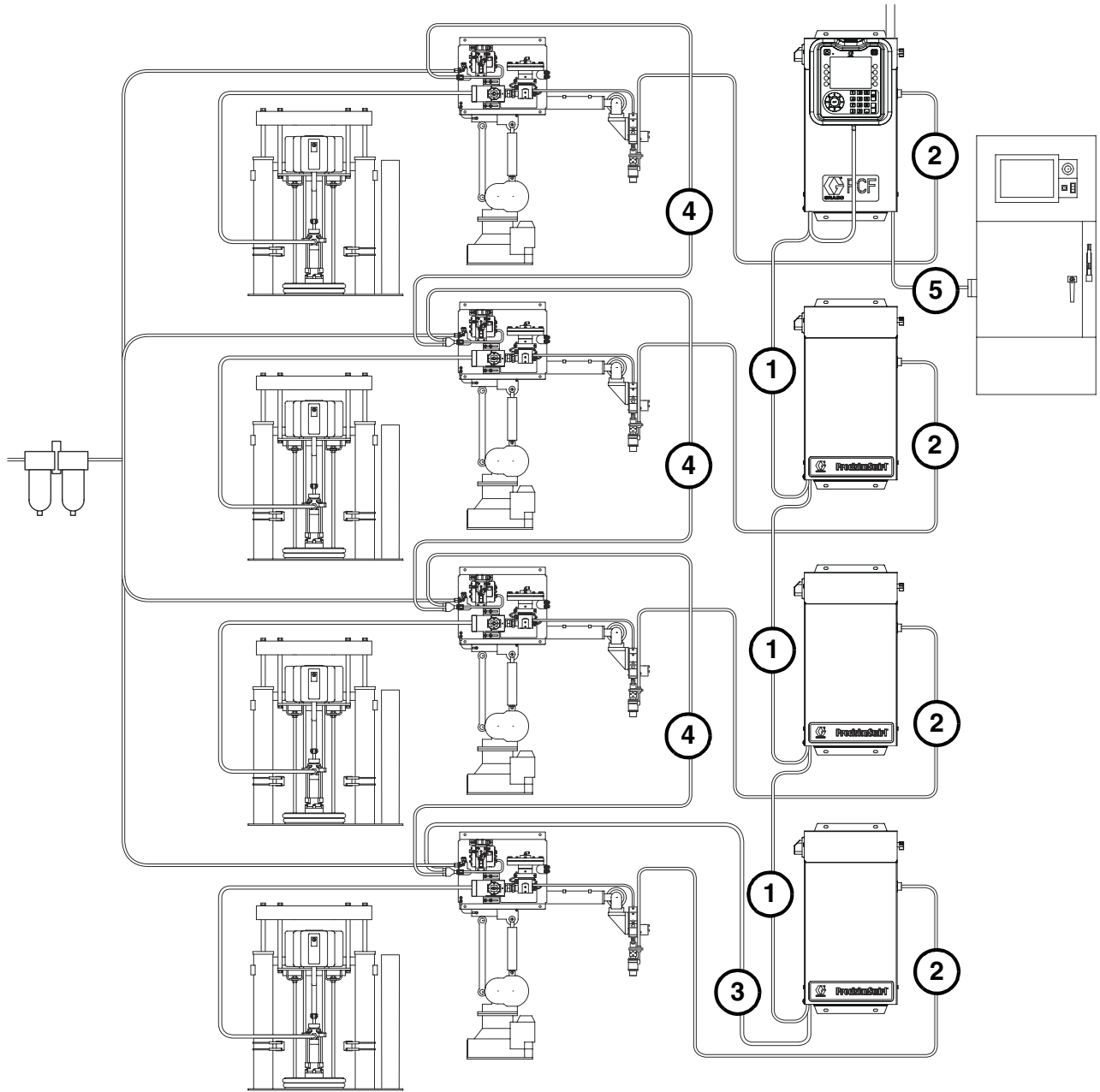

Multiple Fluid Plate and Multiple Swirl System shown

FIG. 17: Cable Installation Diagram

Install Gateway Module Interface

NOTE: Systems with swirl dispensers will have two gateway modules in the control center. The gateway module on the left is the swirl control DGM module, and does not need any setup or modification. The gateway module on the right is the automation Gateway module. This section covers the automation Gateway module.

Fieldbus Communications Gateway Module

Module Description

The Communications Gateway Module (CGM) provides a control link between the PCF system and a selected fieldbus. This provides the means for remote monitoring and control by external automation systems.

See **Automation Control (Normal Operation)**, page 45, for details on controlling the PCF system through the Gateway module.

Data Exchange

Data is available by block transfer, cyclic transfer, change of state triggered, and explicit access to individual attributes as defined by the fieldbus specification. Refer to **Appendix C - Communications Gateway Module (CGM) Connection Details**, page 138, for details about PCF/fieldbus data map.

NOTE: The following system network configuration files are available at www.graco.com

- EDS file: DeviceNet or EtherNet/IP fieldbus networks
- GSD file: PROFIBUS fieldbus networks
- SDML: PROFINET fieldbus networks

CGM Status LED Signals

Signal	Description
Green on	System is powered up
Yellow	Internal communication in progress
Red Solid	CGM hardware failure
*Red (7 flashes)	Data map load failure
	Incorrect data map for fieldbus type
	No data map loaded

*The red LED (CF) will flash a code, pause, then repeat.

Installation

NOTE: The following installation instructions assume the person implementing the PCF fieldbus connection fully comprehends the fieldbus being used. Ensure the installer understands the automation controller communication architecture and the fieldbus being used.

1. Install interface cables between the PCF system and the automation controller per the fieldbus standards. Refer to **Appendix C - Communications Gateway Module (CGM) Connection Details**, page 122, for details.
2. Turn on system power. Navigate to the Gateway setup screens and ensure the data map name is: PCF 4FP. Refer to **Appendix A - Advanced Display Module (ADM)**, page 99, for details about the data map.
3. Set the PCF Gateway configuration values as required to interface with automation controller. Refer to **Appendix A - Advanced Display Module (ADM)**, page 99, for details about the configuration settings.
4. Retrieve the appropriate fieldbus configuration file for the fieldbus being used from www.graco.com.
5. Install the configuration file on the automation controller (fieldbus master). Configure it for communication with the PCF Gateway (fieldbus slave).
6. Establish communication between the automation controller and the PCF Gateway to confirm the successful configuration of the hardware and data.

NOTE: Use the ADM screens for troubleshooting fieldbus data communication problems. Refer to **Appendix A - Advanced Display Module (ADM)**, page 99, for details. Also, use the LED status indicators on the PCF Gateway module for fieldbus status information. Refer to **Appendix C - Communications Gateway Module (CGM) Connection Details**, page 122, for details.

Discrete Gateway Module

Module Description

The Discrete Gateway Module (DGM) provides a control link between the PCF system and an automation controller through discrete input and output connections. This provides the means for remote monitoring and control by external automation systems.

See **Automation Control (Normal Operation)**, page 45, for details on controlling the PCF system through the Gateway module.

Connect D-Sub Cable

The DGM provides all I/O through the D-Sub cable. Graco offers two options for connecting a D-Sub cable to the D-Sub connector (CG). Both options are accessories and must be ordered separately.

- *For single fluid plate systems only:* D-Sub to flying leads cable (123793). See **Appendix B - Discrete Gateway Module (DGM) Connection Details**, page 115, for details and cable interface signals.
- *For multiple fluid plate systems:* D-Sub cable (123972) and 78-pin breakout board (123783). See **Appendix B - Discrete Gateway Module (DGM) Connection Details**, page 115, for details and pin assignments.

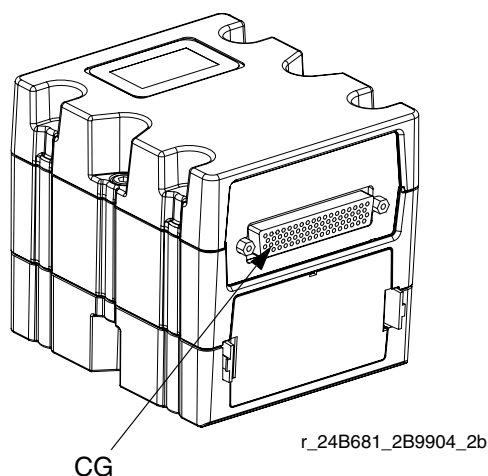

FIG. 18: Connect D-Sub Cable

DGM Status LED Signals

See **LED Diagnostic Information**, page 65, for signal definitions.

DGM Rotary Switch Position

The Discrete Gateway Module (DGM) rotary switch must be in position 0 for Automation Gateway DGMs and positions 1-4 for Swirl Control DGMs in order for the DGM to operate. See **Automation Gateway Module** on page 18 and **Swirl Control DGM** on page 19.

System Setup

Overview

The PCF system compensates for temperature, flow, or pressure fluctuations. However, if there is a hardware change on the supply system or the dispense material is changed, the PCF system must be set up again.





After material is loaded into the supply system, set up the PCF system using the Setup screens. The following procedure outlines the major system setup steps. The following subsections provide instructions to complete each setup step. Once these steps are complete the module is ready for operation.

NOTE: See the **Advanced Display Module (ADM)** section, page 17, and **Appendix A - Advanced Display Module (ADM)**, page 99, for detailed operating instructions for the display keypad and each screen.

1. Configure System, page 32.
2. Configure Control Settings, page 33.
3. Configure Mode Settings, page 34.
4. Configure Delay Settings, page 34.
5. Configure Flow Meter Settings, page 35.
6. Configure Pressure Loop Settings, page 35.
7. Adjust Pressure Sensors, page 36.
8. Configure Errors, page 36.
9. Setup Maintenance Schedule/Parameters, page 37.
10. *For systems with swirl dispensers only:*
 - a. Configure Swirl to valve association and error type, page 37.
 - b. Configure Swirl settings, page 38.
11. Configure Gateway Settings, page 38.
12. Setup Styles, page 38.
13. Configure Advanced Settings, page 38.

Configure System

Define the number of installed fluid plates (called “Dispenser” on this screen) and number of installed swirl dispensers. If a fluid plate is listed as “Uninstalled” the screens for that fluid plate will not appear in the run or setup screens.

1. With the system in setup mode, navigate to the System screen.
2. Press  to access the fields to make changes.
3. Use the arrow keys to navigate to the desired field.
4. Press  to open the drop-down list, and select the desired setting. Press  to accept the selection.
5. Repeat for the other Dispensers and Swirl Dispensers.
6. Press  to exit edit mode.

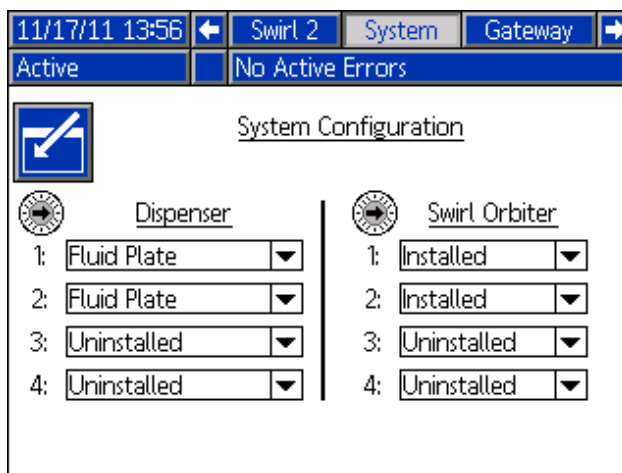



FIG. 19

Configure Control Settings

Set the controls for the dispense source, how dispense commands are sent, and job settings.

1. With the system in setup mode, navigate to Fluid Plate x, screen 1 (Control Settings).
2. Press  to access the fields to make changes.

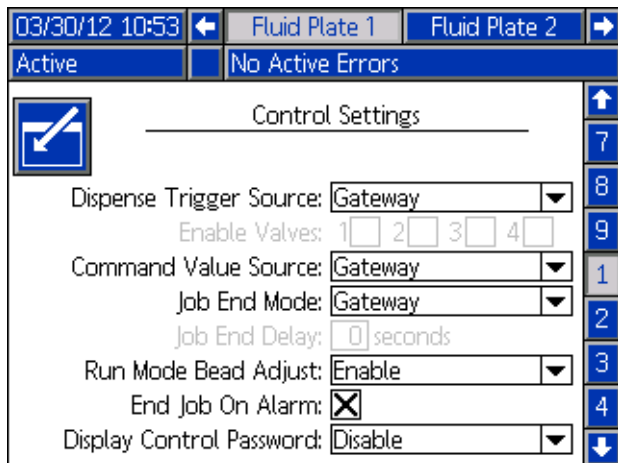

























FIG. 20

3. Press  to open the Dispense Trigger Source drop-down list, and select Gateway, Command Cable, Command Cable 3x, or Combined. If Command Cable is selected, users can enable the valves. Press  to finalize the selection.
4. If the dispense trigger source is set to Command Cable, press  to move to the Enable Valves field. Press  and  and  to enable valves.
5. Press  to move to the Command Value Source field. Press  to open the drop-down list, and select Gateway, Command Cable, or Display. Press  to enter the value.
6. Press  to move to the Job End Mode field. Press  to open the drop-down list, and select Timer or Gateway. Press  to enter the value.
7. Press  to move to the Job End Delay field. Enter the desired delay time (in seconds). Press  to enter the value.
8. Press  to move to the Run Mode Bead Adjust field. Press  to open the drop-down list, and select Enable or Disable. Press  to enter the value.
9. Press  to move to the End Job on Alarm Check-box. Press  to enable or disable.
10. Press  to move to the Display Control Password field. Press  to enter the value.
11. Press  to exit edit mode.
12. *If multiple fluid plates are installed, repeat this procedure for the other Fluid Plates.*

Configure Mode Settings

Set valve commands, including the dispense mode (pressure, bead, shot, or full open) and flow rate or pressure for each valve. The bead scale is also adjustable from this screen.

NOTE: For a description of each dispense mode, see **Dispense Control Modes**, page 112.

1. With the system in setup mode, navigate to the Fluid Plate x, screen 2 (Mode Settings).
2. Press  to access the fields to make changes.

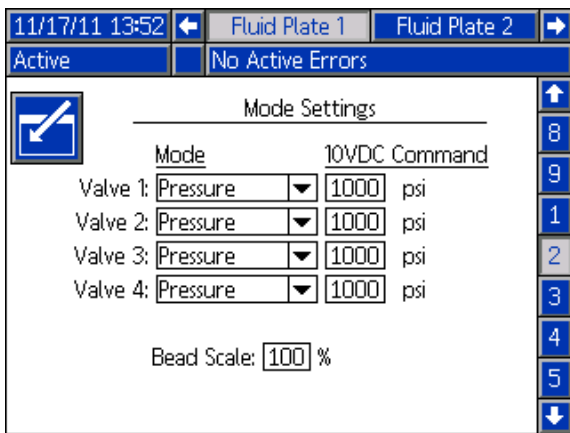









FIG. 21

3. Press   and  to set the mode for each valve that will be used to Pressure, Bead, Shot, or Full Open. Press  to enter each selection.
4. Use the four arrow buttons to navigate to each Fixed Command field. Enter the desired value for each valve that will be used. Press  to enter each value.

NOTE: The ability to dispense from multiple valves simultaneously is only allowed in either of the following scenarios.

- Each valve is set to Pressure mode and has identical Fixed Command values.
- Each valve is set to Full Open mode.

Attempting to dispense from multiple valves simultaneously using any other combination will cause an Incompatible Valves Settings alarm.

5. Press  to move to the Bead Scale field. Enter a scale value between 50% and 150%. Press  to enter the value.
6. Press  to exit edit mode.

Configure Delay Settings

Set on and off delays (in milliseconds) for each valve and the regulator. For an explanation of the on and off delays, refer to the **On/Off Delays** section on page 39.

1. With the system in setup mode, navigate to the Fluid Plate x, screen 3 (Delay Settings).
2. Press  to access the fields to make changes.

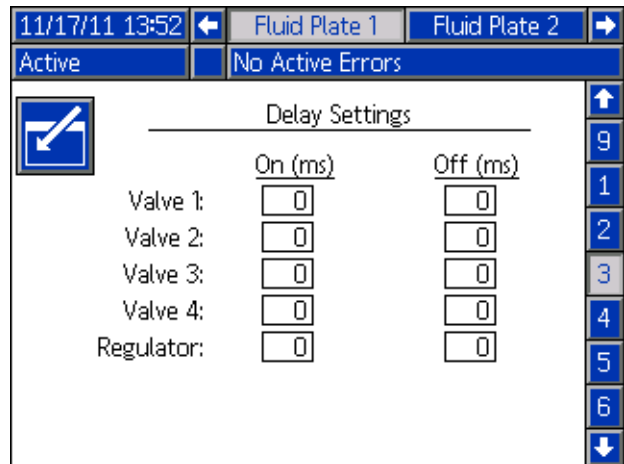



FIG. 22

3. Use the four arrow buttons to navigate to each On and Off field. Enter a desired delay value (in milliseconds) for each valve that will be used and the regulator. Press  to enter each value.
4. Press  to exit edit mode.

Configure Flow Meter Settings

The accuracy of the PCF volume reporting depends on precise adjustment of the K-factor(s). The fluid plate uses the K-factor(s) to calculate the volume dispensed. If the set value is not correct, the system still delivers repeatable flow rates; however, the reported value may not be correct. See **Verify Flow Meter Calibration**, page 42, for additional K-factor information.

Table 5: Flow Meter K-Factors

Part	Description	K-Factor
246652	High Resolution Helical Gear Meter	7000
246340	Heated Helical Gear Meter	3500
16E993	Ultra High Flow Meter	33000

Set Flow Meter K-Factor

NOTE: In systems without a flow meter, the flow meter settings will be grayed out.

1. With the system in setup mode, navigate to the Fluid Plate x, screen 4 (Pressure Loop and Flowmeter Settings).
2. Press  to access the fields to make changes.

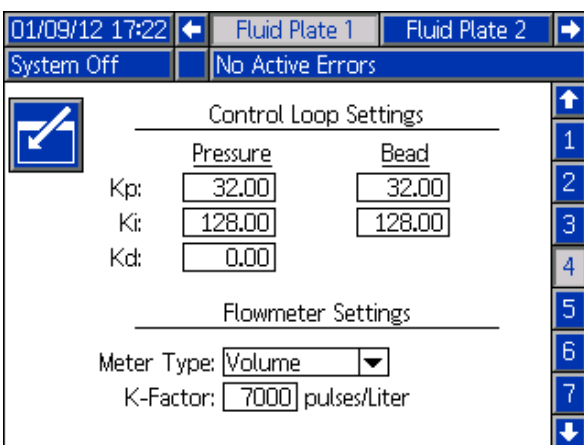







FIG. 23

3. Press  to open the Meter Type drop-down list, and select the meter type used by the system. Select Volume for volumetric flow meters or Mass for mass flow meters. Press  to enter the selection.
4. Press  to move to the K-Factor field. Key in the K-factor value. See **Table 5: Flow Meter K-Factors** for values. Press  to enter the value.
5. Press  to exit edit mode.

NOTE: If necessary, verify flow meter calibration. See **Verify Flow Meter Calibration**, page 42, for instructions.

Configure Pressure Loop Settings

The PCF system uses variables (K_p , K_i , and K_d) in the software calculations to accurately and precisely control the fluid pressure.

NOTE: It is recommended that these values are not changed from the factory defaults of 32.00 for K_p , 128.00 for K_i , and 0.00 for K_d . However, if the values need to be adjusted, see **Manually Adjust Control Loop Parameters** on page 43.

Adjust Pressure Sensors

Set pressure offsets and pressure limits.

NOTE: Inlet sensor settings will be grayed out on this screen for systems with heated fluid plates.

1. With the system in setup mode, navigate to the Fluid Plate x, screen 5 (Pressure Sensors).
2. Press  to access the fields to make changes.

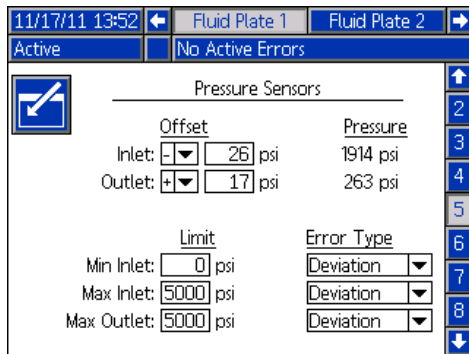







FIG. 24

NOTE: For the following steps, press   and  to navigate through each field, and  to open drop-down menus and enter changes or selections.

3. Set the desired offset for the inlet and outlet pressures between 0 and 100 psi (0.7 MPa, 7.0 bar). Remove all pressure on the sensors, and then adjust the offset so the measured value reads 0.

NOTE: It is recommended that offsets should not be changed from the factory defaults of 0.

4. Set the desired minimum and maximum pressure limits for the inlet, and the desired maximum pressure limit for the outlet.
5. Set the error type (alarm or deviation) that will be issued:
 - If the minimum inlet pressure decreases below the setting.
 - If the maximum inlet pressure increases above the setting.
 - If the maximum outlet pressure increases above the setting.
6. Press  to exit edit mode.

Configure Errors

Set the error type (alarm, deviation, or none) that will be issued if the pressure, flow rate, volume, or computed target goes outside the tolerance settings of the active style. When an alarm occurs, the system stops dispensing. When a deviation occurs, the system will continue dispensing. See **Fluid Plate x, Screen 6 (Error Type)** on page 107 for more information.

NOTE: Only the low/high pressure errors will be enabled for systems without a flow meter.

1. With the system in setup mode, navigate to Fluid Plate x, screen 6 (Error Type).
2. Press  to access the fields to make changes.

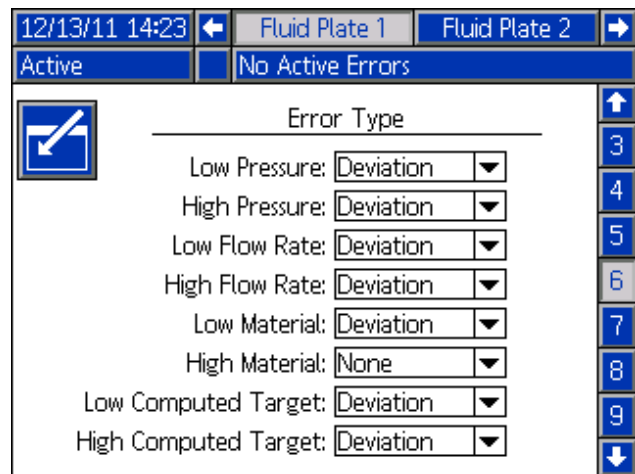





FIG. 25

3. Press  to open the Low Pressure drop-down list, and select either Alarm or Deviation for the error type. Press  to enter the selection.
4. Press  to move to the next field. Repeat Step 4 for each field.
5. Press  to exit edit mode.

Setup Maintenance Schedule/Parameters

Set the volume (or hours) limit that will trigger a maintenance advisory for the fluid supply, Voltage to Pressure (V/P) Transducer, fluid regulator, flow meter, and all four valves.

NOTE: Hours is shown instead of Volume for fluid plates without a flow meter.

The Volume (or Hours) column displays the current totalizer value. If this value exceeds the set limit, the value will turn red and a maintenance advisory is issued. See **Fluid Plate x, Screen 7 (Maintenance Advisory Limits)**, page 108, for more information about maintenance totalizers.

To set limits:

1. With the system in setup mode, navigate to the Fluid Plate x, screen 7 (Maintenance Advisory Limits).
2. Press  to access the fields to make changes.

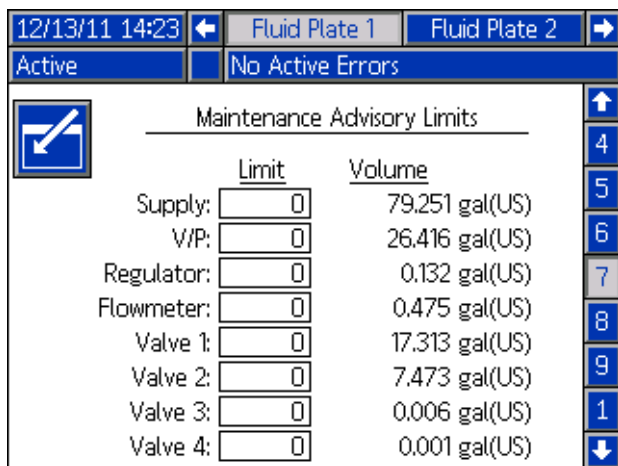







FIG. 26

3. Enter the desired limit for the air supply and press  to enter the selection.
4. Press  to move to the next field. Repeat Step 4 for each field.
5. Press  to exit edit mode.

To reset a totalizer value:

1. Follow Steps 1-3 of **To set limits:** to make changes in Fluid Plate x, screen 7 (Maintenance Advisory Limits).
2. Press  to scroll to the system component to reset.
3. Press  to reset the value.

Configure Valve to Swirl Association and Motor Error Type

Define which Swirl number is installed on which dispense valve.

Set the error type (alarm or deviation) that will be issued if a motor fault occurs. When an alarm occurs, the fluid plate stops dispensing. When a deviation occurs, the fluid plate will continue dispensing.

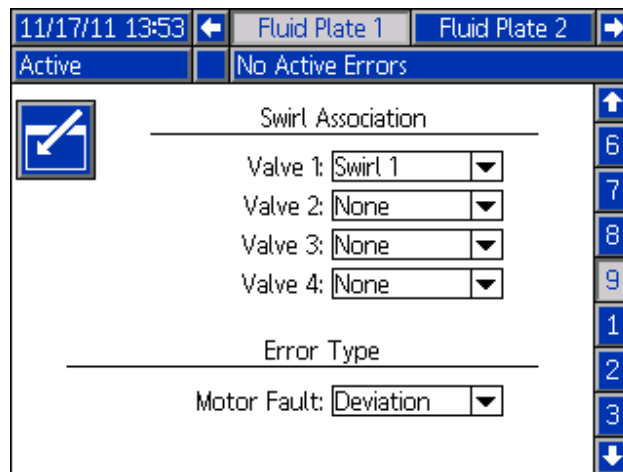

FIG. 27

Configure Swirl Settings

NOTE: This applies only to systems with swirl dispensers.

Set the individual Swirl settings for each installed Swirl.

Maintenance Advisory Limits	
Limit	Hours
Swirl Orbiter: 100	0.293

FIG. 28

Configure Gateway Settings

Gateway settings differ for each system. See **Automation Gateway Setup Screens**, page 102, for guidelines on configuring each type of Gateway interface.

Setup Styles

The PCF system can store up to 256 styles. See **Styles**, page 46, for more information about styles and instructions on setting up styles. Style 0 is always the purge style.

Configure Advanced Settings

Use the advanced settings to set or change the format and display units, such as the language, date format, and pressure units, for all PCF screens. See **Setup Mode**, page 101, for advanced setting guidelines.

On/Off Delays

The PCF fluid regulator can physically respond faster than the dispense device and its solenoid. As a result, the fluid regulator can supply material to the dispense device before the device has time to open. Supplying material to a closed device can create trapped-pressure.

At the end of a cycle, the dispense device can shut off before the pressure has dissipated. This can cause a dispense of an excess of material at the beginning of the next cycle.

To eliminate these two problems, change the delay time associated with the opening of the fluid regulator/dispense and/or the closing of the dispense device, see **Table 5: On/Off Delay Variables**. For instructions setting on/off delays, see **Configure Delay Settings**, page 34.

NOTE: On/Off delay can be set for each dispense device.

In general, delays should be adjusted so the outlet pressure during “no flow” is slightly below the outlet pressure during dispense.

Table 5: On/Off Delay Variables

Variable:	Sets the Amount of Time:
Valve ON	Sets time from Dispense Valve High to Valve Open command
Regulator ON	Sets time from Dispense Valve High to Regulator ON
Valve OFF	Sets time from Dispense Valve Low to Valve Close command
Regulator OFF	Sets time from Dispense Valve Low to Regulator OFF

FIG. 29 and **Table 6: Delay On/Off Timing** show delay ON and OFF timing.

Table 6: Delay On/Off Timing

A	Regulator ON delay	The user sets the fluid regulator ON delay timing.
B	Valve ON delay	Usually set to zero. Can be used to change the starting point of a bead.
C	Valve OFF Delay	Usually set to zero. Higher values will lower the trapped pressure.
D	Regulator OFF delay	The user sets the regulator OFF delay timing. Zero or small values will lower the trapped pressure.
E	Valve Open Reaction Time	Time delay for valve to physically open. Delay varies based on pneumatic hose length and valve air volume.
F	Valve Close Reaction Time	Time delay for valve to physically close. Delay varies based on pneumatic hose length and valve air volume.

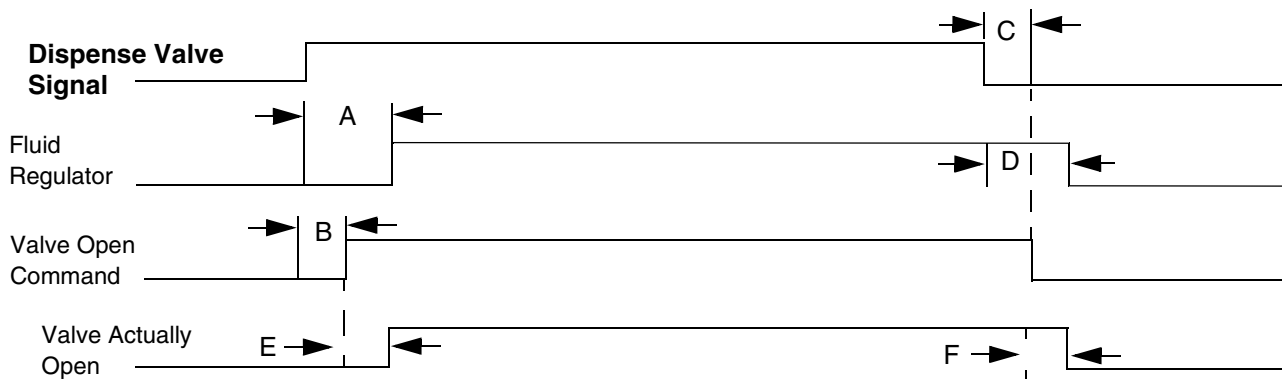

FIG. 29: Timing Delay

Operation

Pressure control may degrade at low output pressures. It is not recommended to dispense at outlet pressures less than 500 psi (3.4 MPa, 34 bar).

Startup

Initial Startup



1. Ensure the PCF control center is installed and all of the proper connections to and from the control center have been made. Ensure fittings are tight.
2. Read and understand the **Operation** (page 40) and **Advanced Display Module (ADM)** (page 17) sections of this manual.
3. Continue startup with step 2 in Standard Startup.

Standard Startup

1. Carefully inspect the entire system for signs of leakage or wear. Replace or repair any worn or leaking components before operating the system.
2. Press the Stop button (BC). See FIG. 8 on page 17.
3. Turn on air.
4. Turn on electrical power to the system.
5. Turn on the main power to supply power to the PCF.
6. **Check Interface Signals:** If this is a new installation, power on each system input and verify that each input is being received.
7. Turn on the material supply system.



Load Material



Before using the system material must be loaded into the supply system.

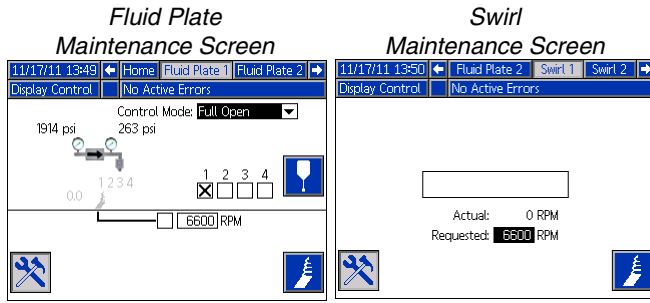

1. If this is a new installation, follow the **Initial Startup** procedure. Otherwise, follow the **Standard Startup** procedure. See page 40.
2. Turn on the fluid supply pressure to the fluid plate assembly.
3. Place the valve(s) over a waste container.
4. Enter the maintenance screen. See **Dispense From Maintenance Screen**, page 43.
5. Select a control mode. See **Dispense From Maintenance Screen**, page 43.
6. If the system status indicator LED (BB) is orange, press  to turn the system on.
7. Press and hold . Dispense fluid until clean, air-free fluid flows from the valve.
8. Press  to exit maintenance screen.

Maintenance Mode Operation



Operating from maintenance mode enables manual dispensing () and manually starting the swirl dispenser ().

The system begins dispensing when the user presses . Dispense parameters and duration depend on the selected control. Dispensing continues for as long as  is pressed.

The system starts the swirl dispenser when the user presses . The swirl dispenser continues to run until  is pressed again.

There is one maintenance screen for each installed fluid plate and each installed Swirl. The maintenance controls for the Swirl are shown on both the Swirl maintenance screen and on the Fluid Plate maintenance screen for the fluid plate where the swirl dispenser is installed.

Verify System Operation

Use maintenance mode to manually check the operation of the PCF system components before switching over to automation control (normal operation). See **Dispense From Maintenance Screen**, page 43, for instructions on operating from maintenance mode.

NOTE: Perform the following procedures while in maintenance mode.

Set Inlet Pressure

The inlet pressure reading should be in the range of 300 psi (2.1 MPa, 21 bar) to 500 psi (3.4 MPa, 34 bar) above the outlet pressure reading under your highest flow condition.

Follow steps in the supply system manual to set the inlet pressure.

NOTICE

Inlet pressure beyond the recommended range above will cause accelerated wear on the regulating valve and the pump feed system.

Feed System Pressure Drop

During material flow, the regulator inlet pressure decreases. The amount the pressure decreases is the amount of pressure lost between the feed pump and the regulator inlet.

With high viscosity fluids, long line lengths, or small diameter line sizes this pressure decrease can be thousands of psi (hundreds of bar). This means that the static pump pressure is set much higher than the regulator needs at its inlet. To prevent excessive control regulator wear or surging, a mastic fluid pressure regulator is recommended on the feed line close to the control regulator. The mastic regulator will suppress the static feed pressure at the control regulator inlet.

Dispense from Each Valve



Dispense from each valve that will be used in normal operation to confirm that the entire system is installed correctly and is capable of delivering desired results.

Follow the steps outlined in **Dispense From Maintenance Screen**, page 43, to perform each of the following applicable system verification checks.

NOTE: Each fluid plate controls only the dispense valves connected to it.

- For each valve that will be used during normal operation, dispense at each pressure or flow rate that will be used during normal operation. This verification check confirms that the system is capable of delivering material at your maximum desired operating point.
- For systems that will operate multiple valves in pressure mode at the same time, dispense from each valve at the same time. This verification check confirms that the system is capable of delivering material at your maximum desired operating point.
- For each valve operating in bead mode, perform an initial teaching process. Follow this procedure after significant system and/or material characteristic changes.
 - a. For each flow rate that will be used during normal operation, press  until PCF achieves the flow rate setpoint.

NOTE: During the initial system operation verification, it may take four to five seconds for the system to learn system characteristics.

- b. Continue to press  for several seconds after the desired flow rate is reached to confirm that the system is capable of maintaining the desired flow rate.
- c. Repeat Steps a and b for a range of flow rates to confirm that the system responds quickly to achieve setpoint when  is pressed.

Verify Flow Meter Calibration

Most sealant and adhesive materials are compressible. Since the flow meter measures the material under high pressure, the actual volume of material dispensed may vary slightly from the measured volume, due to this compressibility. If the K-factor is not correct, the displayed volume will not be accurate.

Follow either of the following methods to calibrate the flow meter during initial setup and on a routine basis to check for flow meter wear.

Method 1. Using a gram scale

1. Record the flow meter k-factor shown on Fluid Plate x, screen 4 (Flowmeter Settings). See FIG. 23 on page 35.
2. Use a 500 cc or larger beaker. Measure the mass of the empty beaker.
3. Manually dispense material into the beaker. Hold the beaker so that the stream of material is submerged in the captured material to minimize air entrapment in the container.
4. Record the volume dispensed on Fluid Plate x, screen 1. See FIG. 30 on page 43.
5. Calculate the actual volume dispensed:

$$\frac{\text{fluid mass (g)}}{\text{density (g/cc)}} = \text{measure volume (cc)}$$

6. Calculate the new flow meter K-factor:

$$\text{K-Factor (new)} = \frac{\text{displayed volume (cc)} \times \text{K-Factor (old)}}{\text{measured volume (cc)}}$$
7. Enter new K-factor.
8. Repeat the procedure to verify the new K-factor.

Method 2. Without using a gram scale, visual measurement

1. Record the flow meter k-factor shown on Fluid Plate x, screen 4 (Flowmeter Settings). See FIG. 23 on page 35.
2. Use a 500 cc or larger beaker.

3. Manually dispense material into the beaker. Hold the beaker so that the stream of material is submerged in the captured material to minimize air entrapment in the container.
4. Record the volume dispensed on Fluid Plate x, screen 1. See FIG. 30 on page 43.
5. Settle the material into the beaker and view the actual volume dispensed.
6. Calculate the new flow meter K-factor:

$$\text{K-Factor (new)} = \frac{\text{displayed volume (cc)} \times \text{K-Factor (old)}}{\text{dispensed volume (cc)}}$$

7. Enter new K-factor.
8. Repeat the procedure to verify the new K-factor.

Manually Adjust Control Loop Parameters

NOTE: It is recommended that these values not be changed from the factory defaults of 32.00 for Kp, 128.00 for Ki, and 0.00 for Kd.

If the system is not maintaining the desired setpoint while in pressure or bead control mode, manually change the Kp and Ki values:

NOTE: Pressure parameters should be adjusted first, even if you typically operate in bead control mode.

1. Begin dispensing material.

NOTE: Begin a new dispense each time control parameters are changed.

2. *If the regulator outlet pressure does not closely follow the desired pressure, set Ki to zero then increase Kp until the proper pressure control is achieved.*
3. *If the regulator outlet pressure oscillates rapidly above and below the commanded pressure, decrease Kp by 10%. Continue to decrease the Kp value in 10% increments until the outlet pressure is stable.*
4. Set Ki value to 2 then increase the Ki value until the system oscillates.
5. Decrease Ki until oscillation stops.

6. *Optional:* To fine tune the step response in pressure mode, gradually increase the Kd value.

NOTE: Increasing Kd (pressure only) is typically not necessary but it may improve step response. However setting Kd too high may cause the system to oscillate.

7. Stop dispensing.

Dispense From Maintenance Screen

1. Navigate to Fluid Plate x, screen 1 for the desired fluid plate.

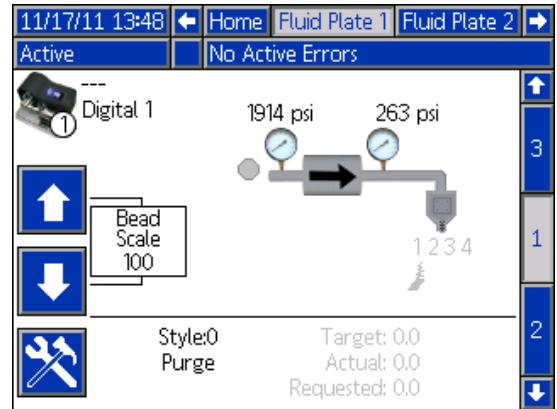

FIG. 30

2. Press to enter maintenance screen.

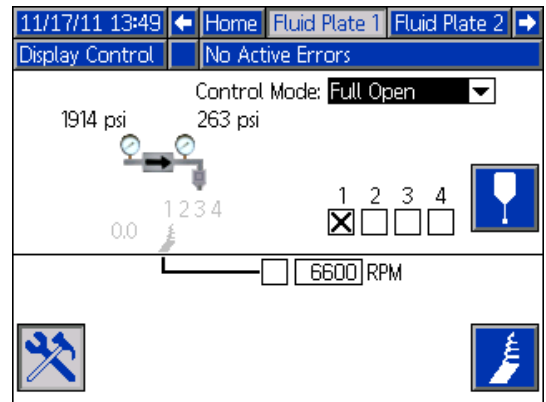









FIG. 31

3. Press to open the Control Mode drop-down list, and select the preferred control mode. Press again to exit the drop-down list.

Operation

- Press  to move to the target fields. Enter the target pressure, flow rate, or volume (dependent on control mode) and press  to save.
- Press  to move to the valve check boxes. Press  to select the desired valves.
- Follow step 2 - 4 of **Manually Dispense Fluid**, page 44.

Manually Dispense Fluid

- From Fluid Plate x, screen 1, press  to enter maintenance screen.
- Press  and verify that the valve opens.
- Continue to press  as long as needed to load or dispense material.
- Press  again to exit maintenance screen.

Operate Swirl Dispenser From Maintenance Screen

- Navigate to the Swirl x screen for the desired Swirl Dispenser. If the Swirl Dispenser is installed on Fluid Plate x, you may also navigate to Fluid Plate x, screen 1.

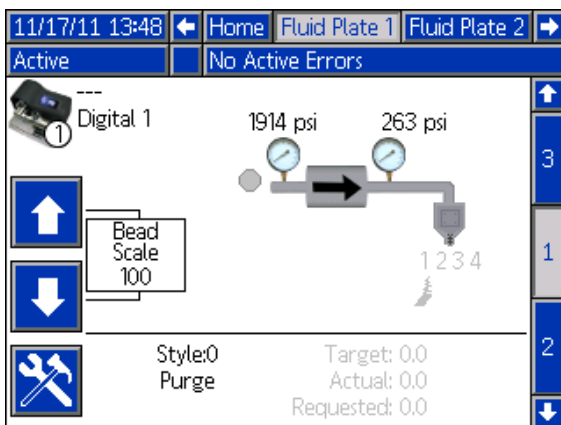



FIG. 32

- Press  to enter maintenance screen.

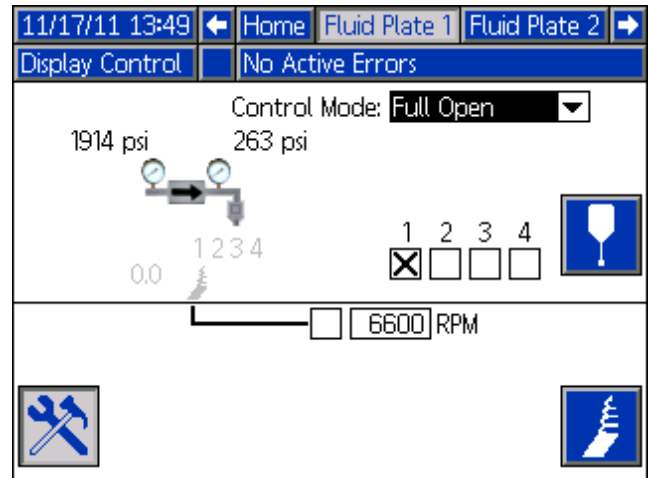





FIG. 33

- To change the RPM, use the arrow keys to navigate to the RPM box then enter the desired RPM.
- Press  and verify that the Swirl Dispenser begins rotating. Press  again to stop the Swirl Dispenser.
- Press  again to exit maintenance screen.

Automation Control (Normal Operation)

During automation control (normal operation), the system can dispense or change dispense parameters when it receives a command from the automation unit.

The automation control operates using the concept of jobs and styles. For a detailed explanation of jobs and how they work within the PCF system, see **Jobs** on page 45. For a detailed explanation of styles and how they work within the PCF system, see **Styles** on page 46.

Jobs

NOTE: See **Appendix D - I/O Signal Descriptions**, page 138, for automation input and output signal descriptions.

A job is an automation sequence in which material can be dispensed. The amount of material specified for a job varies by application. In some applications, a job may be the amount of material dispensed on a part. Other applications may define a job to be the amount of material dispensed on a number of parts or dispensed over a period of time.

A job is initiated when the automation sends a Style Strobe signal to the PCF. Once the job is initiated, the PCF will start tracking the amount of volume requested by the automation and the amount of material that is actually dispensed. These volumes will be tracked until the job is completed. At the end of the job, error calculations are made and the volumes are stored on the PCF system (Job Log).

The PCF system monitors two things to determine when a job is complete. Either the Dispense Complete signal is sent by the automation or the job complete timer expires. The type of job end signal is configured to Timer or Gateway in Fluid Plate x, screen 1 (Control Settings). If the timer method is used, the timer begins counting every time the dispense valve is turned off. If the valve stays off for more than the preset timer value, the job is considered complete.

Once the job is complete, the job information is stored to memory. The most recent jobs can be viewed on the Job screen. The information stored with each job is as follows. See **Job Report Screens**, page 114, for instructions on how to view job reports.

Actual (Measured) Volume - The amount of material measured by the flow meter during a job.

Requested Volume - The amount of material that the automation tries to dispense during a job. In Bead mode, the requested volume is calculated as the requested flow rate multiplied by the duration of the dispense. In all other modes, the requested volume is same as the target volume.

Target Volume - The amount of material a job should have. This is defined in the Style.

Jobs in Bead Mode

In Bead Mode, all of the previously mentioned volumes are monitored. The High Volume, Low Volume, and Computed Target errors are evaluated at the end of the job. The volume alarms compare the measured volume to the requested volume and the computed target alarm compares the requested volume to the target volume.

Jobs in Pressure Mode

In Pressure Mode, the requested volume is not measured. In this mode, the automation command voltage corresponds to a pressure instead of flow rate. For this reason the requested volume is not available (as well as the Computed Target error). The high and low volume alarms compare the measured volume to the target volume for pressure mode.

Continuously Running Applications

In some cases the target volume for a job is not known. An example of a case where the target volume is unknown is a continuously running system. This would be a system that does not run jobs, but runs continuously over a day or a shift. In this case, the flow rate becomes more important than the amount of volume dispensed in a job. The way to handle this situation is to set the target volume to a value of zero. This effectively disables the Computed Target error. The controls will still maintain the desired flow rate and report errors corresponding to the tolerance set for the running style.

Styles

The PCF system has the ability to handle up to 256 styles, depending on the selected option.

NOTE: The number of available styles depends on the fluid plate configuration. See **Models** on page 4. Style 0 is specified for purging only.

For each style, an independent target volume and tolerance can be configured. This allows for job-related errors and logs to be evaluated for each style. The style is read at the beginning of a job and cannot be changed until the next job.

PCF reads in the styles via the Gateway interface. For detailed interface information, see **Appendix B - Discrete Gateway Module (DGM) Connection Details** on page 115, and **Appendix C - Communications Gateway Module (CGM) Connection Details** on page 122, as applicable.

To setup a style:

1. Navigate to Fluid Plate x, screen 8.
2. Press  to access the style setup fields.

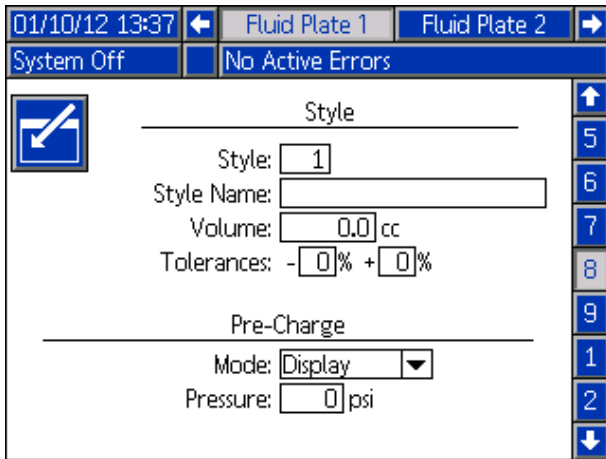



FIG. 34

3. Enter the style number in the Style field.
4. Enter Style Name:
 - a. Press  while in the Style Name field to display the Keyboard screen.

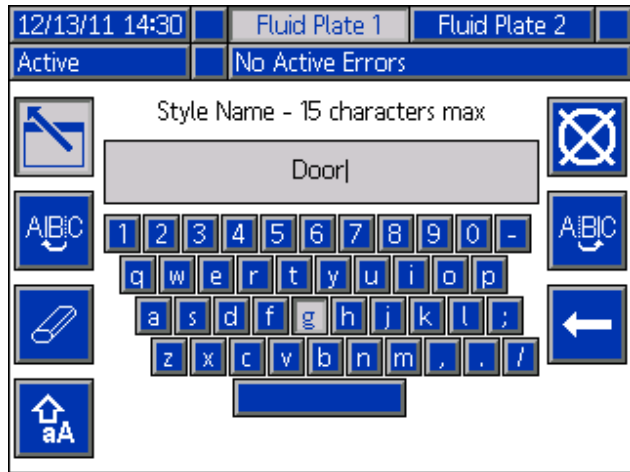





FIG. 35

- b. Use the arrow buttons on the ADM to scroll through each letter. Press  to enter a letter in the style name field. See **Keyboard Screen**, page 109, for further details.
 - c. Press  to accept the new value.
5. Enter the target volume in the Volume field, and the tolerance percentages in the Low and High Tolerance fields.
6. Enter precharge mode and parameters. See **Pre-charge Modes** beginning on page 47.
7. Press  to exit edit mode.

Precharge Modes

NOTE: See the diagram on the following page.

Static Precharge Mode

Display

When Display precharge mode is selected, a static precharge pressure can be defined. When a job is active and all dispense valves are closed, the regulator will maintain the defined precharge pressure.

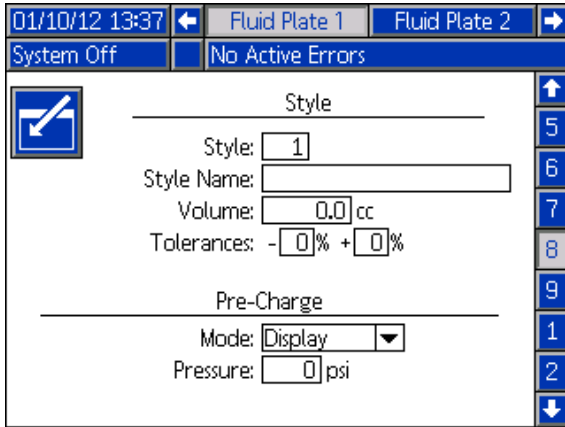

Gateway

NOTE: Gateway precharge mode is only available for systems containing CGMs.

When “Gateway” precharge mode is selected, the outlet pressure will be set according to the current pressure/flow command using the scaling set for dispense valve(s) selected through the gateway interface.

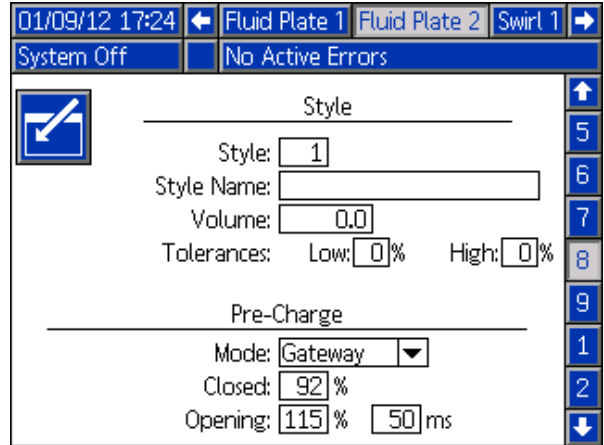

Dynamic Precharge Modes

Dynamic precharge control allows the system to better prepare for the upcoming dispense. The pressure/flow command is used to actively set the outlet pressure to the ideal pressure while all dispense valves are closed and provide a boost while the valve is opening to help accelerate material.

The “Closed” scaling will be applied when all dispense valves are closed and the “Opening” scaling will be applied immediately after a dispense valve starts to open and continue for the user-specified duration (in milliseconds). The precharge scaling values modify the control signals that are necessary to obtain the desired pressure/flow. The precharge pressure can be changed dynamically throughout the job by varying the pressure/flow command value.

Valve 1

When the “Valve 1” precharge mode is selected, the outlet pressure will be set according to the current pressure/flow command using Valve 1 scaling values.

Closed Precharge Scaling Value

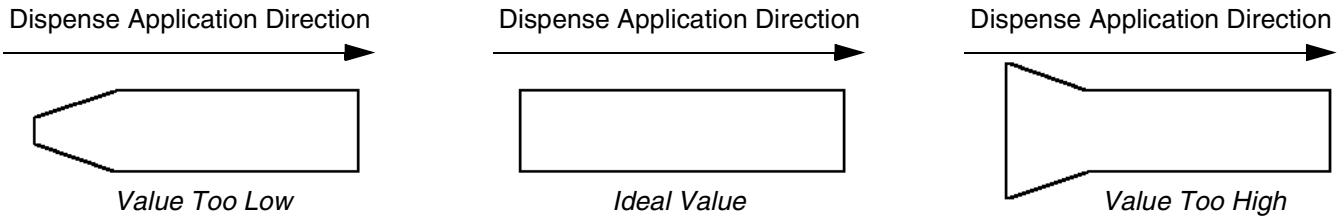

- Controls outlet pressure based on desired command while valves are closed.
- Ideal value is typically less than 100% due to the minimal pressure losses within the system when fluid is not flowing.

Opening Precharge Scaling Value

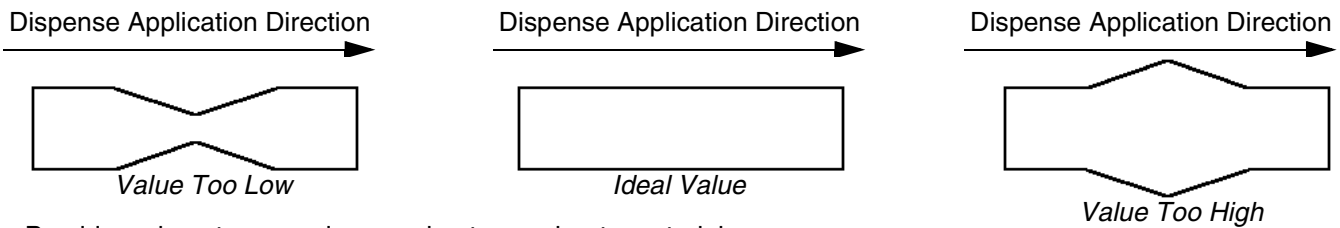

- Provides a boost upon valve opening to accelerate material.
- Ideal value is typically greater than 100%.

Opening Precharge Duration Value

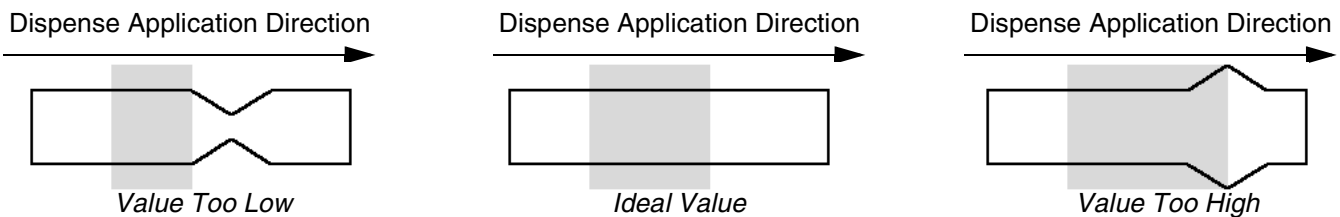

- The duration for which the valve opening scaling is application before the command is no longer scaled.

Regulator On Delay Value

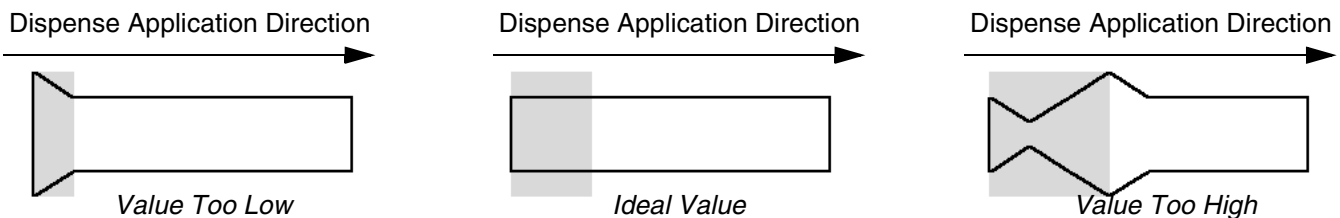

- Controls timing of transition from valve "closed" precharge to valve "opening" precharge and regular dispense.
- This delay should approximate the time it takes a dispense to open.

Typical Job Cycle

In order for the system to run it must be in the active state (status LED next to  on the ADM is green). Before a job begins the automation controller outputs should have the following values:

- Style Strobe: 0
- Dispense Complete: 0
- Dispense Valve x On: all should be 0
- Style: Any value is acceptable

A typical job cycle consists of the following dispensing sequence. See **Typical Job Cycle Chart**, page 50.

NOTE: Each job cycle can apply to only one fluid plate.

1. The automation controller checks that Dispenser (Fluid Plate) Ready signal is set to 1. If it is set to 1, a job can begin.
2. The automation controller sets the Style to the next desired style value.

NOTE: Each fluid plate has a unique set of styles. For example, Style 2 for Fluid Plate 1 is different from Style 2 for Fluid Plate 2.

3. The automation controller sets the Style Strobe to 1.
4. PCF reads the Style bits to select the new style. The system then starts a new job and sets Dispense In Process to 1.
5. The automation controller begins dispensing. The automation controller sets and clears Dispense Valve x On bits as desired throughout the course of the job.
6. When the dispense is complete the automation controller sets Dispense Complete to 1.

7. PCF sets the following signals based on the results of the job.
 - Dispenser (Fluid Plate) No Alarm
 - Dispenser (Fluid Plate) No Error
 - Dispense Volume OK
 - Error
 - Dispensed Volume

NOTE: The automation controller should not read the Dispense Volume OK or Dispense Volume signals until after the system clears the Dispense In Process signal.

8. PCF sets Dispense In Process to 0 to indicate the job is complete. At this time the signals from step 7 should be read.
9. The automation controller must clear Dispense Complete and Style Strobe (either can be cleared first) before the next job can start.

Jobs with Command Cable Dispense Trigger

With the Dispense Trigger Source configured to Command Cable or Command Cable 3x, users only need to trigger the dispense applicator to start a job. This configuration is useful for less demanding applications that do not require a full automation interface.

The following limitations apply when starting a job with this configuration:

- The selected style defaults to Style 1.
- There can be up to a 100 ms delay before dispensing while PCF prepares for the new job cycle.
- The job end mode timer must be used to end a job.

Typical Job Cycle Chart

NOTE: Swirl can be turned on at any point inside of or outside of a job. Allow time for the swirl to reach desired RPM. If possible, verify Swirl speed through the automation interface prior to opening the dispense valve.

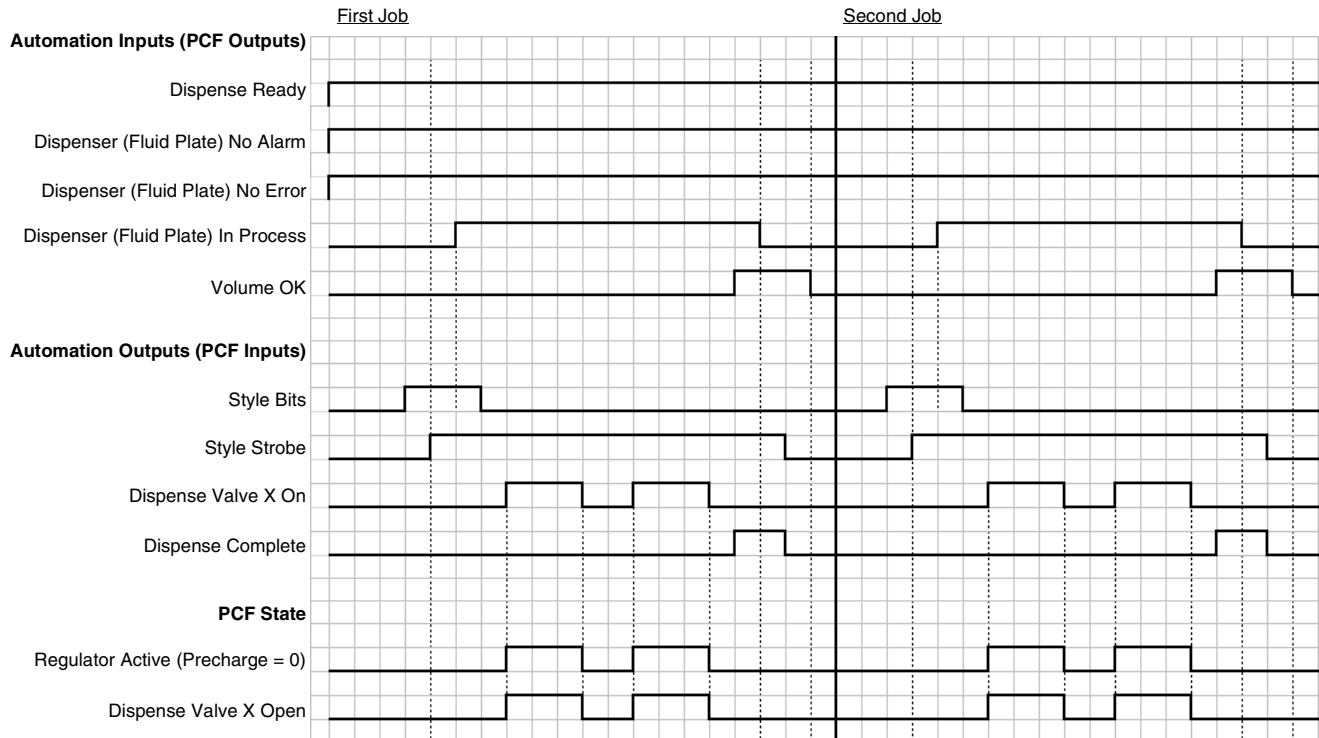

Control Charts

Purge Using Style 0

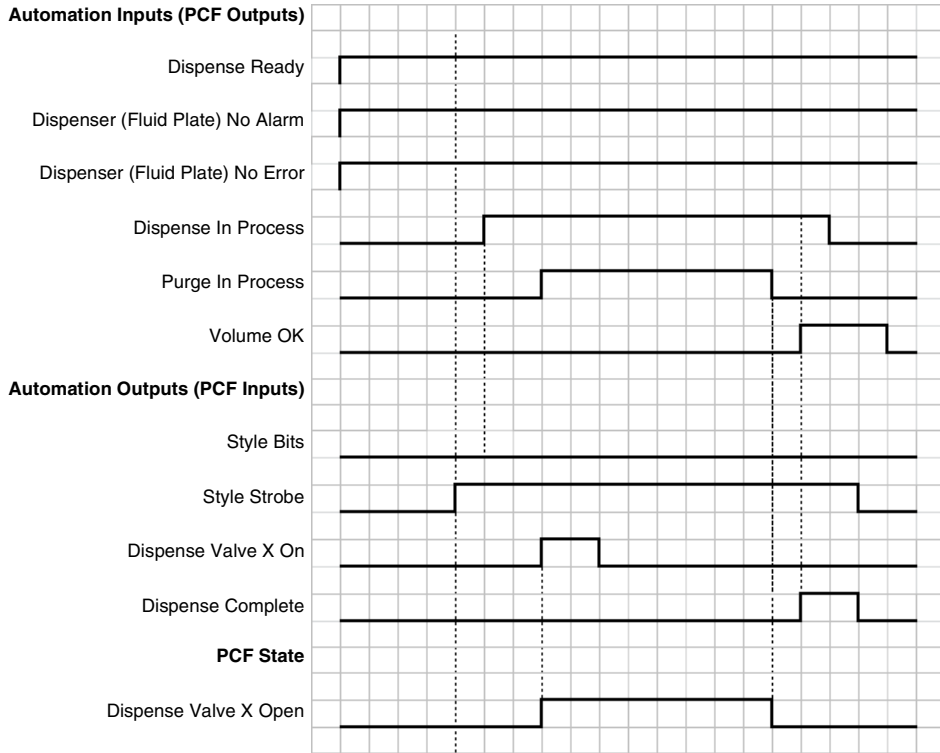

Purge Using Purge Bit

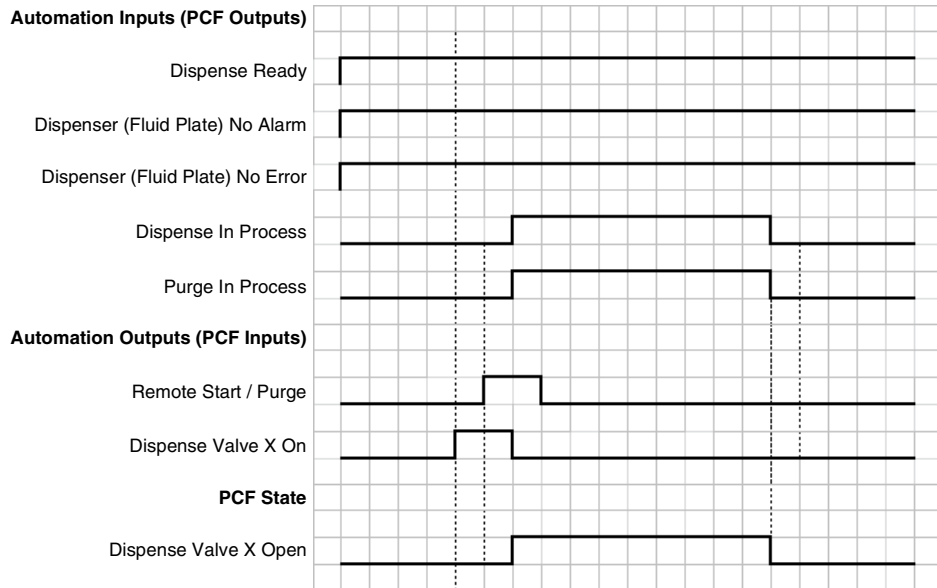

Control Charts (continued)

Remote Start

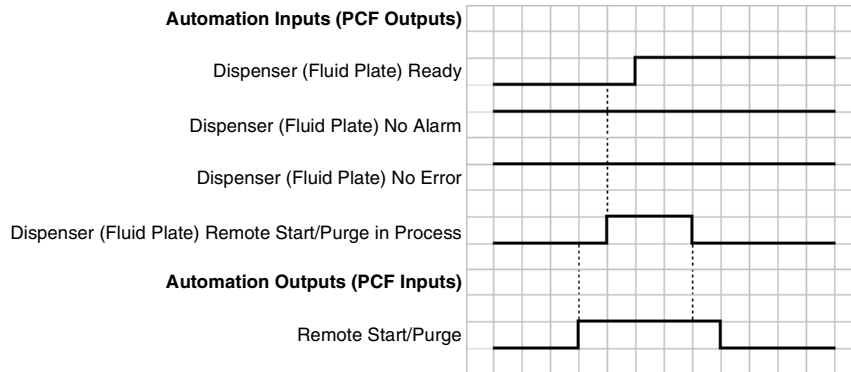

Error Reset

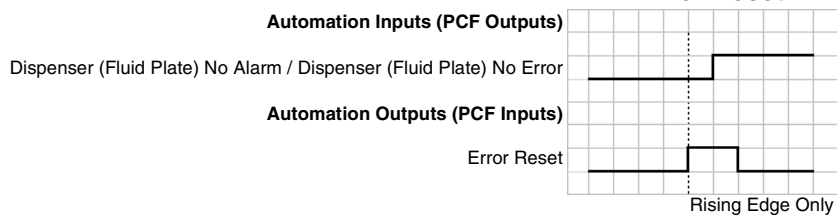

Cancel Job

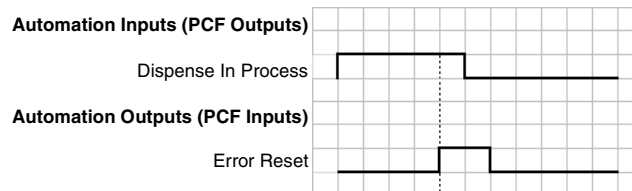

Control Charts (continued)

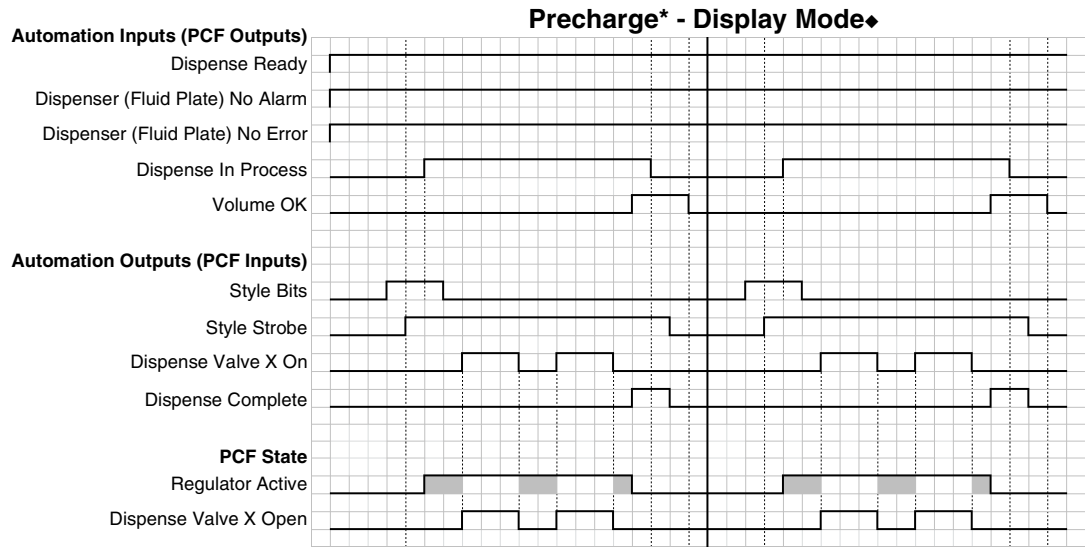

* **Precharge:** After starting a job and prior to opening the dispense valve, the fluid pressure is increased to try to match the dispensing pressure. This helps the consistency of the dispense.

◆ Shaded areas indicate the precharge is active.

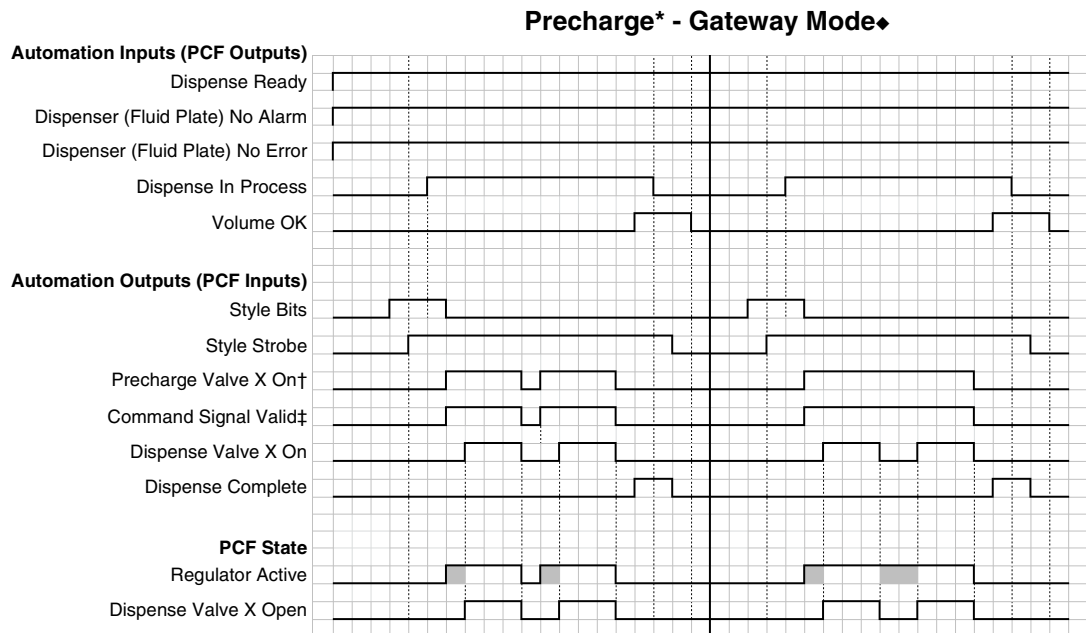

* **Precharge:** After starting a job and prior to opening the dispense valve, the fluid pressure is increased to try to match the dispensing pressure. This helps the consistency of the dispense.

◆ Shaded areas indicate the precharge is active.

† The "Precharge Valve X On" bits are only available through a fieldbus interface. This precharge method is not valid for DGM systems.

‡ Only applies to command signals when either "Command Cable" or "gateway" is selected as "Command Value Source".

Control Charts (continued)

Precharge* - Valve 1 Mode◆

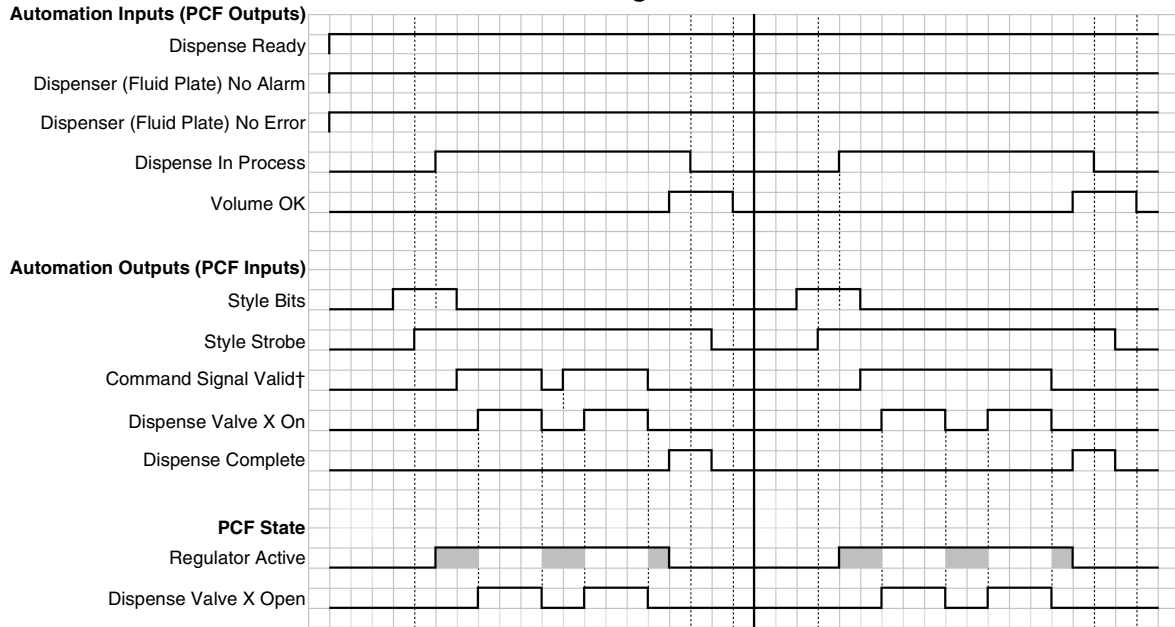

* **Precharge:** After starting a job and prior to opening the dispense valve, the fluid pressure is increased to try to match the dispensing pressure. This helps the consistency of the dispense.

◆ Shaded areas indicate the precharge is active.

† Only applies to command signals when either "Command Cable" or "gateway" is selected as "Command Value Source". In systems containing an automation gateway DGM, when "Digital" is selected as the "Command Value Type", the "Digital CMD 1" and "Digital CMD 2" inputs set the command.

Trigger Using Command Cable 3x

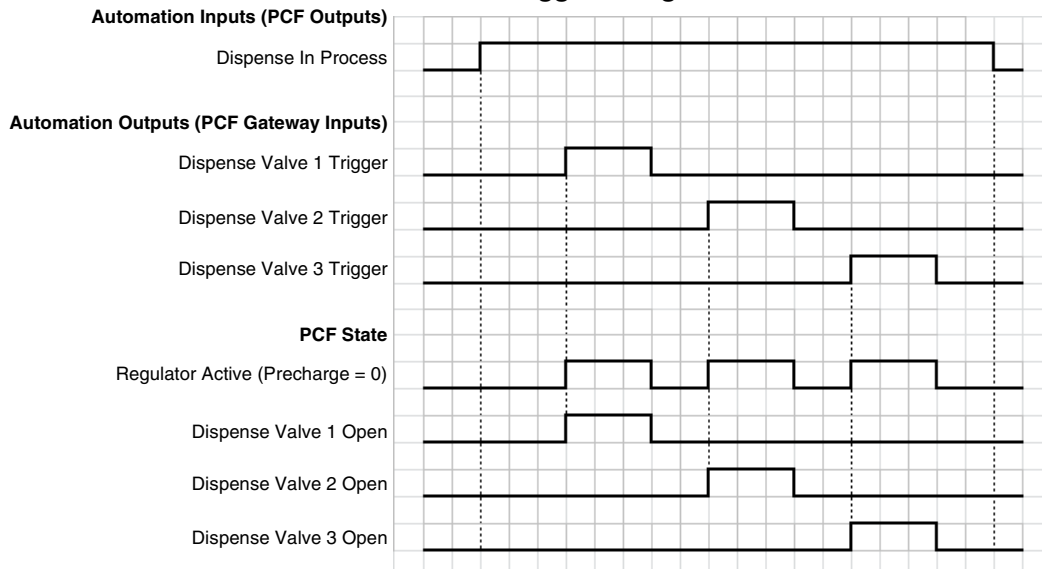

Control Charts (continued)

Trigger Using Command Cable

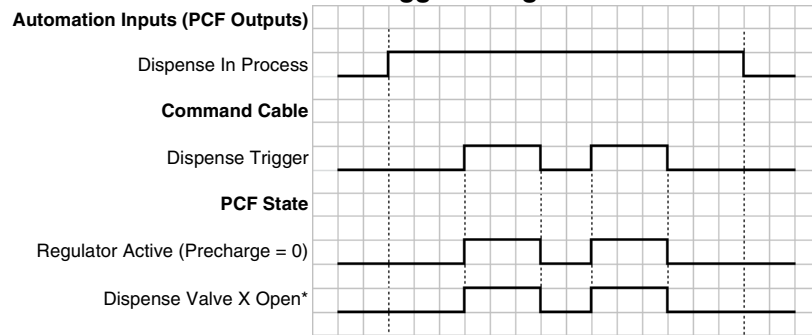

* Dispense Valve X Open determined by Enable Valves check boxes on Fluid Plate x, screen 1(Control Settings).

Trigger Using Gateway

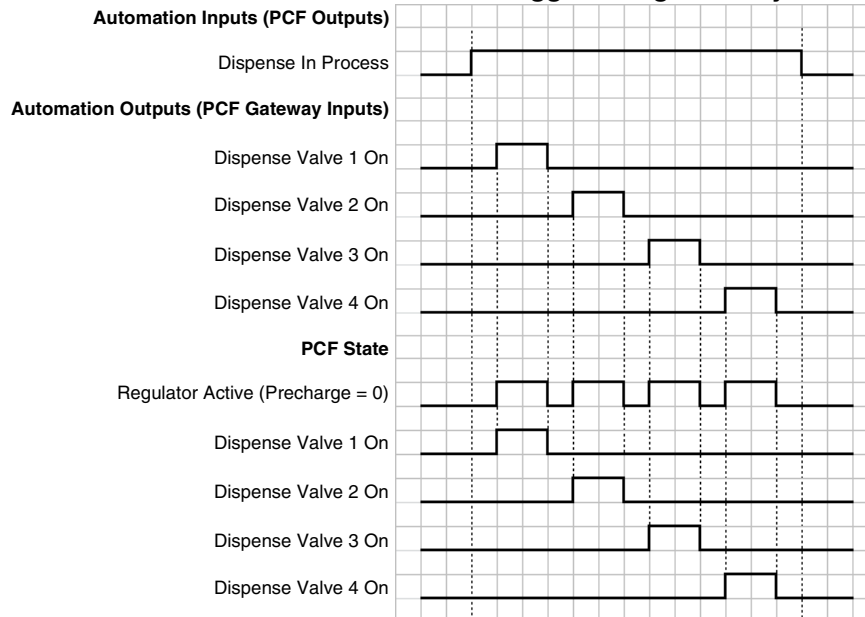

Trigger Using Command Cable and Gateway (Combined)

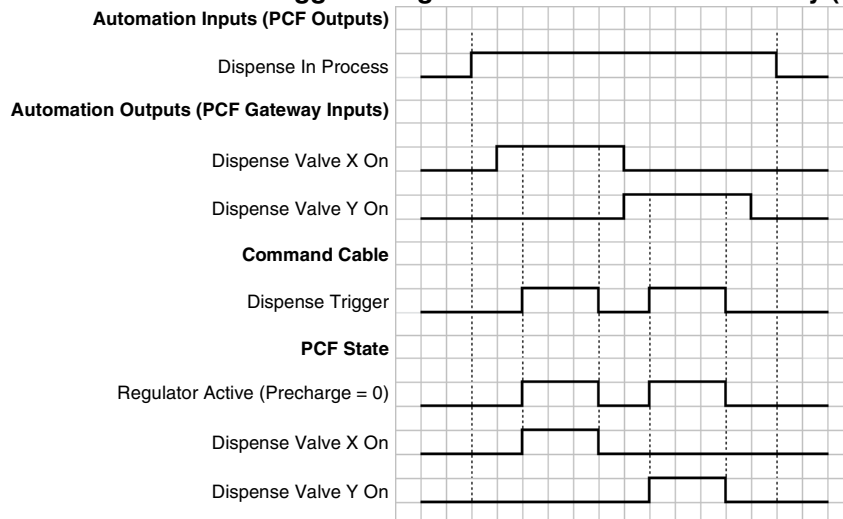



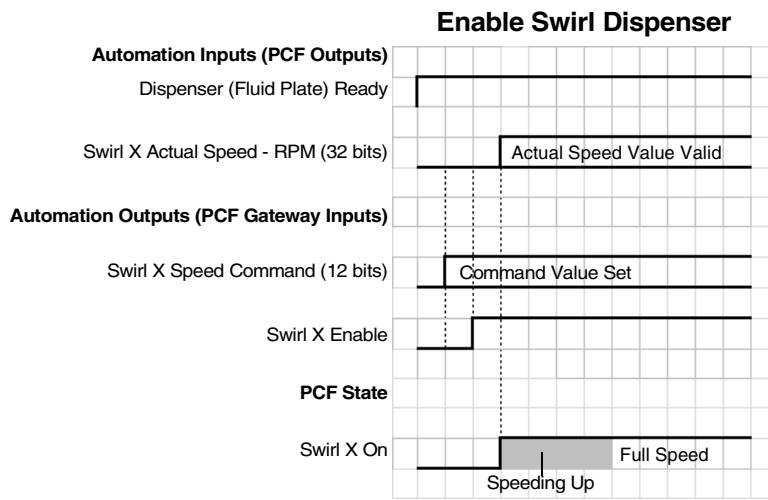



Control Charts (continued)



NOTE: Swirl orbiter may take a few seconds to reach full speed.

Pressure Relief Procedure

						
<p>The equipment stays pressurized until pressure is manually relieved. To help prevent serious injury from pressurized fluid such as skin injection, splashing fluid and moving parts, follow the Pressure Relief Procedure when you stop dispensing and before cleaning, checking or servicing the equipment.</p>						

1. Shut off the fluid supply to the fluid plate assembly.
2. Place a waste container beneath the dispense valve.
3. In maintenance mode, select Full Open Dispense Mode, which opens the regulator and dispense valve. Press the manual dispense button  until the fluid flow stops.
4. If the dispense valve cannot be actuated from the control center, refer to FIG. 36 and perform the following steps to open the dispense valve and relieve fluid pressure:
 - a. Manually actuate the plunger on the solenoid to open all dispense valves attached to this fluid plate and relieve fluid pressure. See FIG. 36.

Dispense Valve Air Solenoid

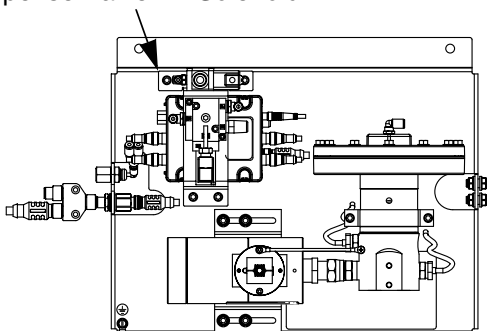

FIG. 36: Dispense Valve Air Solenoid

- b. Continue actuating the plunger until all pressure is purged from the system between the needle and the dispense valves attached to this fluid plate before proceeding to the next step.
5. For systems with multiple fluid plates, repeat previous steps for other fluid plates.
 6. Shut off air to the fluid plate.
 7. Place a waste container below the air filter assembly then open drain valve on the air filter assembly. Close drain valve once air is relieved.
 8. Turn main power switch on control panel to the OFF position.



9. If you have followed the previous steps and suspect that a valve, hose, or dispense nozzle is clogged or that pressure has not been fully relieved, very slowly remove the dispense tip, clean the orifice, and continue relieving pressure.
10. If this does not remove the clog, cover the hose end coupling with a rag then very slowly loosen the hose end coupling to relieve pressure gradually, then loosen the coupling completely. Clear the valves or hose. Do not pressurize the system until the blockage is cleared.

Shutdown



1. Press the Stop button (BC).

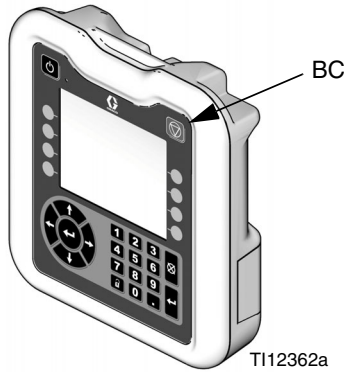

FIG. 37: ADM - Stop Button

2. Shut off the material supply to the fluid plate/meter.
3. Follow the **Pressure Relief Procedure** on page 57.
4. Turn off the PCF system's compressed air supply.
5. Turn main power switch on control panel to the OFF position.

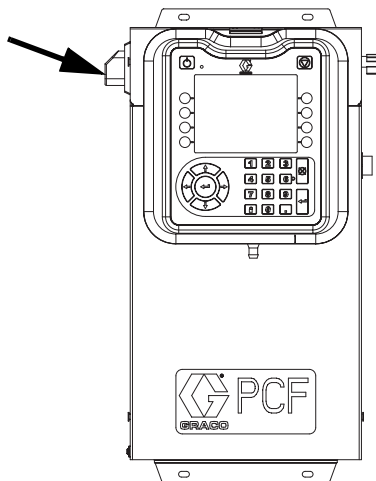

FIG. 38: Control Center Main Power Switch

USB Data

All files downloaded from the USB are put in a DOWNLOAD folder on the drive. For example:
 “E:\GRACO\12345678\DOWNLOAD\”

The 8-digit numeric folder name matches the 8-digit ADM serial number. When downloading from multiple ADMs, there will be one sub-folder in the GRACO folder for each ADM.

USB Logs

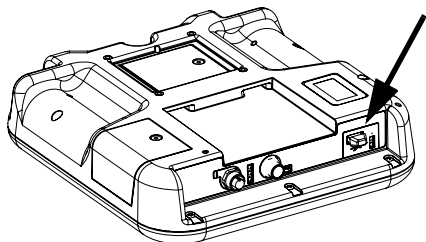

Fig. 39: ADM USB Port

During operation, PCF stores system and performance related information to memory in the form of log files. PCF maintains three types of log files: a job log, an event log, and dispense data logs. Follow the **Download Procedure**, page 61, to retrieve log files.

Event Log

The event log file name is 1-EVENT.CSV and is stored in the DOWNLOAD folder.

The event log maintains a record of the last 1,000 events. Each event record in the log file contains the date and time the event occurred, the event type, event code, and event description.

Job Log

The job log file name is 2-JOB.CSV and is stored in the DOWNLOAD folder.

The job log maintains a record of the last 10,000 jobs. At the completion of each job the following data is stored in the log file:

- Job completion date
- Job completion time
- Job number (sequential number)
- Dispenser (Fluid Plate) Number
- Style number

- Target volume (in the units shown in the volume units column)
- Requested volume (in the units shown in the volume units column)
- Actual dispensed volume (in the units shown in the volume units column)
- Volume units
- Error percentage between actual dispensed volume and requested volume (maximum of 100%)
- Minimum inlet pressure during job (measured in bar, heated systems will always read 0)
- Average inlet pressure during job (measured in bar, heated systems will always read 0)
- Maximum inlet pressure during job (measured in bar, heated systems will always read 0)
- Minimum outlet pressure during job (measured in bar)
- Average outlet pressure during job (measured in bar)
- Maximum outlet pressure during job (measured in bar)
- Minimum flow rate during job (measured in cc/min, systems with no flow meter will read 0)
- Average flow rate during job (measured in cc/min, systems with no flow meter will read 0)
- Maximum flow rate during job (measured in cc/min, systems with no flow meter will read 0)
- Elapsed time (mS)

Dispense Data Log

The dispense data log file name is 3-DATAx.CSV and is stored in the DOWNLOAD folder. There is one dispense data log file for each installed fluid plate, so there can be up to four data logs.

The dispense data log maintains a record of system inlet pressure (heated systems will always read 0), system outlet pressure, system flow rate (systems without flow meters will always read 0), and active dispense valves. This data is recorded at one second intervals when a job cycle is in process. Each dispense data log is capable of storing up to two hours of data.

System Configuration Settings File

The system configuration settings file name is SETTINGS.TXT and is stored in the DOWNLOAD folder.

A system configuration settings file automatically downloads each time a USB flash drive is inserted. Use this file to back up system settings for future recovery or to easily replicate settings across multiple PCF systems. Refer to the **Upload Procedure**, page 61, for instructions on how to use this file.

It is recommended to retrieve the SETTINGS.TXT file after all system settings are set as desired. Store the file for future use as a backup in case the settings are changed and need to be quickly changed back to the desired setup.

NOTE: System settings may not be compatible between different versions of the PCF software.

NOTE: Do not modify the contents of this file.

Custom Language File

The custom language file name is DISPTEXT.TXT and is stored in the DOWNLOAD folder.

A custom language file automatically downloads each time a USB flash drive is inserted. If desired, use this file to create a user-defined set of custom language strings to be displayed within the ADM.

The PCF system is able to display the following Unicode characters. For characters outside of this set, the system will display the Unicode replacement character, which appears as a white question mark inside of a black diamond.

- U+0020 - U+007E (Basic Latin)
- U+00A1 - U+00FF (Latin-1 Supplement)
- U+0100 - U+017F (Latin Extended-A)
- U+0386 - U+03CE (Greek)
- U+0400 - U+045F (Cyrillic)

Create Custom Language Strings

The custom language file is a tab-delimited text file that contains two columns. The first column consists of a list of strings in the language selected at the time of download. The second column can be used to enter the custom language strings. If a custom language was previously installed, this column contains the custom strings. Otherwise the second column is blank.

Modify the second column of the custom language file as needed and then follow the **Upload Procedure**, page 61, to install the file.

The format of the custom language file is critical. The following rules must be followed in order for the installation process to succeed.

- The file name must be DISPTEXT.TXT.
- The file format must be a tab-delimited text file using Unicode (UTF-16) character representation.
- The file must contain only two columns, with columns separated by a single tab character.
- Do not add or remove rows to the file.
- Do not change the order of the rows.
- Define a custom string for each row in the second column.

Download Procedure

1. Insert USB flash drive into USB port (BL). See FIG. 39 on page 59.
2. The menu bar and USB indicator lights indicate that the USB is downloading files. Wait for USB activity to complete. A pop-up will be present until the transfer is complete if it is not acknowledged.
3. Remove USB flash drive from USB port (BL).
4. Insert USB flash drive into USB port of computer.
5. The USB flash drive window automatically opens. If it does not, open USB flash drive from within Windows[®] Explorer.
6. Open Graco folder.
7. Open system folder. If downloading data from more than one system, there will be more than one folder. Each folder is labeled with the corresponding serial number of the ADM (The serial number is on the back of the ADM.)
8. Open DOWNLOAD folder.
9. Open LOG FILES folder labeled with the highest number. The highest number indicates the most recent data download.
10. Open log file. Log files open in Microsoft[®] Excel[®] by default as long as the program is installed. However, they can also be opened in any text editor or Microsoft[®] Word.

NOTE: All USB logs are saved in Unicode (UTF-16) format. If opening the log file in Microsoft Word, select Unicode encoding.

Upload Procedure

Use this procedure to install a system configuration file and/or a custom language file.

1. If necessary, follow the **Download Procedure**, page 61, to automatically generate the proper folder structure on the USB flash drive.
2. Insert USB flash drive into USB port of computer.
3. The USB flash drive window automatically opens. If it does not, open USB flash drive from within Windows Explorer.
4. Open Graco folder.
5. Open system folder. If working with more than one system, there will be more than one folder within the Graco folder. Each folder is labeled with the corresponding serial number of the ADM. (The serial number is on the back of the module.)
6. If installing the system configuration settings file, place SETTINGS.TXT file into UPLOAD folder.
7. If installing the custom language file, place DISPTXT.TXT file into UPLOAD folder.
8. Remove USB flash drive from computer.
9. Install USB flash drive into PCF system USB port.
10. The menu bar and USB indicator lights indicate that the USB is downloading files. Wait for USB activity to complete.
11. Remove USB flash drive from USB port.

NOTE: If the custom language file was installed, users can now select the new language from the Language drop-down menu in the Advanced Setup Screen 1.

Troubleshooting



NOTE: Check all possible solutions in the chart below before you disassemble the system.

Troubleshooting for individual fluid regulators and flow meters is also discussed in their separate manuals; refer to **Related Manuals** on page 3. Also refer to **Event and Error Codes and Troubleshooting**, page 67, for detailed information on how error codes are communicated.

Fluid Plates

Problem	Cause	Solution
No outlet pressure	Air pressure low	Verify air pressure is above 60 psi (410 kPa, 4.1 bar)
	No “Valve On” signal from automation unit	Check output and wiring from automation unit
	No air signal to air diaphragm	Check for loose/disconnected connector to Voltage to Pressure (V/P) Transducer; tighten
	False signal being sent to control	Check outlet pressure sensor output; verify that it corresponds to zero pressure; replace sensor and/or amplifier
High outlet pressure	Fluid regulator needle/seat is worn	Rebuild fluid regulator; replace needle/ seat
Air leaks from fluid plate	Loose air connections	Check air connections; tighten if necessary
	Worn gaskets	Check/replace gaskets on Voltage to Pressure (V/P) Transducer and solenoid valve

Flow Meter

Problem	Cause	Solution
No flow measurement	Flow meter pick-up sensor loose	Tighten flow meter pick-up sensor
	Flow too low	Verify flow rate is above minimum for the installed flow meter
	Loose wiring	Verify connection from flow meter to FCM
	Damaged flow meter pick-up sensor	Replace pick-up sensor
False measurement	Flow meter not calibrated	Calibrate flow meter, page 42
	System not grounded properly	Verify system ground
	Noisy power source	Verify clean power supply power to main enclosure
Flow reported is not correct or inconsistent	Flow meter not calibrated	Calibrate flow meter, page 42
	Flow meter is worn	Replace flow meter

Fluid Regulator

Problem	Cause	Solution
No pressure regulation	Damaged diaphragm	Replace diaphragm
	Leaking or dirty seat	Replace cartridge, or clean seat
No fluid flow	Damaged valve actuator	Replace valve actuator
Pressure creeps above setting	Metal chip or contamination between ball and seat	Replace cartridge, or clean seat area
	Damaged diaphragm	Replace diaphragm
	Damaged o-ring or improper seal	Replace the o-ring under the seat
	Damaged or clogged air regulator or line	Clear obstruction in line. Service regulator if necessary
	Leaking or dirty seat	Replace cartridge, or clean seat
	Large change in inlet pressure	Stabilize regulator inlet pressure
Pressure drops below setting	Empty/clogged supply line	Fill/flush supply line
	Damaged or clogged air regulator or line	Clear obstruction in line. Service regulator if necessary
	Using valve beyond its rated flow capacity	Install valve for each spray valve or dispensing valve
	Large change in inlet air or fluid pressure	Stabilize air and fluid regulator inlet pressures
Fluid leaks from spring housing	Loose fluid housing	Tighten the four cap screws
	Damaged diaphragm	Replace diaphragm
Chatter	Excessive pressure differential between pump and valve	Reduce pump pressure to not more than 2000 psi (14 MPa, 138 bar) greater than required valve pressure.
	Excessive flow rate	Reduce fluid flow through regulator. Connect only one spray gun or dispense valve to each fluid regulator

Dispense Valves

Problem	Cause	Solution
Valve not opening	Air not getting to the open port	Verify air pressure to solenoid
	No "Valve On" signal from automation unit	Check input from automation unit
Valve not shutting off	Air not getting to the close port (except AutoPlus valve)	Verify air pressure to solenoid
		Verify solenoid operation
	Verify air line routing and connections	
	"Valve On" signal from automation unit is on	Check input from automation unit
Sluggish open/close	Air pressure low	Verify air pressure is above 60 psi (410 kPa, 4.1 bar)
	Needle/seat worn	Rebuild valve; replace needle/seat
	Pressurized material past the valve shut-off is escaping	Reduce running pressure
		Reduce nozzle length
		Increase nozzle orifice size
	Faulty solenoid valve	Replace solenoid valve
Solenoid valve muffler restricted	Clean or replace muffler	
Material leaks from back of valve	Shaft seal is worn	Rebuild valve; replace seals
Air leaks from dispense valve	Loose air connections	Check air connections; tighten if necessary
	Worn piston o-ring	Rebuild valve; replace piston o-ring

Swirl Dispenser

Problem	Cause	Solution
Motor not running (motor fault alarm active)	Cable disconnected	Verify cable connections to swirl board, swirl motor cable, and swirl orbiter
	CAN cable was re-connected with system power on (amber LED on swirl board will be on, this indicates circuit protection was triggered)	Cycle system power
	Shorted motor cable (amber LED on swirl board will be on, this indicates circuit protection was triggered)	Replace swirl motor cable (55 ft) then cycle power
	Faulty swirl orbiter	Replace swirl orbiter
Motor not running (motor fault alarm not active)	Cable disconnected	Verify cable connections to swirl board, swirl board power cable, and swirl control DGM
	No "Swirl Enable" signal from automation unit	Check input from automation unit
	Swirl not installed	Verify that the proper swirl orbiter is installed in the system setup screen

Motor not responding to change in speed command	No "Swirl Speed Command" signal from automation unit	Check input from automation unit
	Swirl speed source incorrectly set	Verify Speed Command Source in Swirl Setup screen

Gateway Module

Problem	Cause	Solution
No communication	Incorrect wiring	Check wiring per fieldbus standard. Refer to PCF Gateway LED status indicators and Appendix C - Communications Gateway Module (CGM) Connection Details , page 122.
	Incorrect fieldbus settings	Confirm fieldbus settings at automation controller (fieldbus master) and PCF Gateway (fieldbus slave). Refer to Appendix A - Advanced Display Module (ADM) , page 99, for information on PCF Gateway configuration settings.
Incorrect data	Incorrect fieldbus configuration file installed on automation controller (fieldbus master)	Download PCF fieldbus configuration file from www.graco.com , and install on automation controller (fieldbus master).
	Incorrect map installed on PCF Gateway	Confirm correct PCF data map is installed on PCF Gateway. Refer to Appendix A - Advanced Display Module (ADM) , page 99, for information on how to determine installed data map. If necessary, install a new Gateway data map. Refer to Upgrade Gateway Module Fieldbus Map , page 78, for instructions, and Control Center and Expansion Swirl Enclosure Parts , page 92, for map token part number.

LED Diagnostic Information

The following LED signals, diagnosis, and solutions apply to the Advanced Display Module, Fluid Control Module, and Gateway module.

Module Status LED Signal	Diagnosis	Solution
Green on	System is powered up	-
Yellow	Internal communication in progress	-
Red solid	Hardware failure	Replace module
Red flashing fast	Uploading software	-
Red flashing slow	Token error	Remove token and upload software token again.
Red flashes three times, pauses, then repeats	Invalid rotary switch position (FCM and DGM only)	Change rotary switch position to a valid position then restart the system. See page 15.

Errors

View Errors

When an error occurs, an error pop-up is displayed that takes up the entire screen until the error is acknowledged by pressing . Errors can also be acknowledged over the gateway. Active errors are displayed in the menu bar.

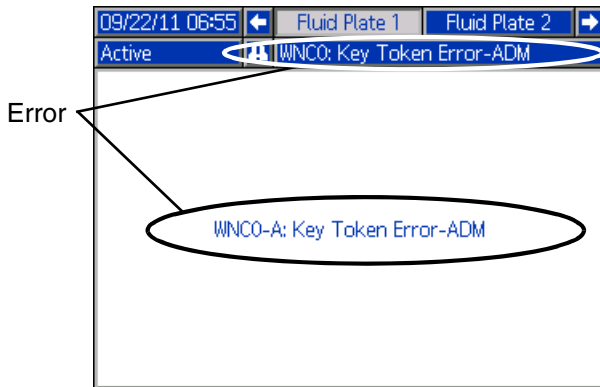

FIG. 40: Error Pop-Up

The previous 200 errors are displayed on the error report screens. See **Run Mode**, page 110, for instructions on navigating to and through the error report screens.

There are three levels of errors: alarms, deviations, and advisories. Alarms cause the system to shut down. Deviations and advisories do not shut down the system.

NOTE:

- Alarms set the dispenser (fluid plate) ready signal LOW.
- Advisories and deviations **do not** set the dispenser (fluid plate) ready signal LOW.

Diagnose Errors

See **Event and Error Codes and Troubleshooting** on page 67 for error codes, possible causes, and solutions.

Event and Error Codes and Troubleshooting

Error codes are stored in the events log and are displayed on the error report screens. Gateway error numbers are reported over the Gateway interface.

Error codes shown as XYZ_ represent error codes XYZ1, XYZ2, XYZ3, XYZ4, where the last digit represents the number of the fluid plate to which the error applies. Error codes in the following table are sorted by gateway error number, then by event code.

System Events and Errors

Event Code	Gateway Error No.	Event Name	Event Description	Event Type	Cause	Solution
System Events and Errors						
---	0	No Active Errors	No errors	---	---	No action necessary
EC0X	---	Setup Values Changed	Setup change notification	Record only	A setup value was changed on the display	No action necessary if changes were desired
EL0X	---	Power Up	Control box power up	Record only	---	No action necessary
EM0X	---	Power Down	Control box power down	Record only	---	---

Control Center Events and Errors

Event Code	Gateway Error No.	Event Name	Event Description	Event Type	Cause	Solution
Control Center Events and Errors						
EVUX	---	USB Disabled	USB download attempted, however, USB activity is disabled.	Advisory (self-clearing)	Transfers are disabled in Advanced Setup screen 2.	Clears when drive is removed.
MMUX	---	USB Log 90% Full	One or more USB log is 90% full.	Advisory	Data in the jobs or events log has not been downloaded recently and logs are nearly full.	Download the data or disable USB errors.
V1G0	---	DGM Unpowered	The Discrete Gateway Module does not have logic power supplied to it.	Advisory	24 Vdc has not been connected to the power pins.	Connect power according to Appendix B - Discrete Gateway Module (DGM) Connection Details on page 115.
WSG0	---	Gateway Setup Error	System settings are incompatible with Discrete Gateway Module.	Advisory	Fluid plate 1 is not installed. Or Fluid plate 3 or fluid plate 4 is installed.	Install fluid plate 1, uninstall fluid plates 3 and 4.
					Swirl 1 is not installed. Or Swirl 3 or Swirl 4 is installed.	Install Swirl 1, uninstall swirls 3 and 4.
EAUX	---	Download to USB in Process	Information is currently being downloaded to USB	Advisory (self-clearing)	---	No action necessary

Event Code	Gateway Error No.	Event Name	Event Description	Event Type	Cause	Solution
Control Center Events and Errors						
EBUX	---	Download to USB Complete	Download to the USB is complete	Advisory (self-clearing)	---	No action necessary
WSU0	---	USB configuration error	USB configuration error	Advisory	USB configuration invalid or not present	Reinstall system software on display
WNC0	32	ADM Key Token Error	Missing or invalid key token	Alarm	An ADM key token is required to run the system	Verify the key token is installed Verify the key token part number is correct for the PCF ADM
WNG0	---	Gateway Map Error	Missing or invalid map	Advisory	Missing or invalid Gateway map	Install PCF map in Gateway
CBG0	---	Gateway Reset	Gateway reset	Advisory (self-clearing)	Gateway setting(s) changed	Wait for reset to complete before attempting automation control
WMG0	---	Gateway Error Detected	Gateway error detected; includes any error not covered by another more specific error	Alarm	---	---
CBD_	---	Fluid Plate Communication Error	Fluid Plate Communication Error with ADM	Alarm	The ADM lost communications with the FCM.	Restore communication.
CCG_	---	Fieldbus Communication Error	Fieldbus Communication Error	Alarm	The automation gateway lost communication with the automation controller.	Restore communications.

Fluid Plate Events and Errors

Event Code	Gateway Error No.	Event Name	Event Description	Event Type	Cause	Solution
Fluid Plate Events and Errors						
CAC_	---	CGM Communication Error	Communication lost between CGM and Fluid Plate	Advisory	Fluid Plate and CGM are no longer communicating	Reconnect or replace CAN cable
					CGM is not functioning	Replace the CGM if the red status LED is solid
CAD_	---	Fluid Plate Communication Error	FCM lost communication with the ADM	Alarm	ADM is not communicating	Reconnect or replace CAN cable
					ADM is not functioning	Replace FCM if red status LED is solid
					ADM does not contain appropriate key token	Verify intended ADM key token is properly inserted
B7C_	30	Style Out of Range	Style is out of range	Alarm	Style requested by automation controller exceeds number of styles available on the fluid plate	Use a style number that is in range Increase number of styles in PCF; purchase accessory key token

Event Code	Gateway Error No.	Event Name	Event Description	Event Type	Cause	Solution
Fluid Plate Events and Errors						
B30_ B40_	31	High Material	Material dispensed during last dispense cycle was above amount requested plus the allowed tolerance	Alarm or Deviation (user selectable)	PCF regulator is not regulating correctly	Check regulator and repair if necessary
					Incorrect style target volume or tolerance	Enter correct values or set tolerance to 0% to disable error
B10_ B20_	32	Low Material	Material dispensed during last dispense cycle below amount requested minus the allowed tolerance	Alarm or Deviation (user selectable)	Partially plugged tip or supply system	Clean tip and/or supply system
					Insufficient flow to PCF regulator inlet	Increase flow rate to regulator inlet
					PCF regulator is not regulating correctly	Incorrect style target volume or tolerance setting
B1C_ B2C_	33	Low Computed Target	Requested volume/mass differs from entered process target by more than entered tolerance for style requested	Alarm or Deviation (user selectable)	Entered process target incorrectly	Enter correct process target
					Entered tolerance incorrectly	Enter correct tolerance
					Requested volume incorrectly	Check automation program
					Automation problem	Verify automation is correct
B3C_ B4C_	34	High Computed Target	Requested volume/mass differs from entered process target by more than entered tolerance for style requested	Alarm or Deviation (user selectable)	Entered process target incorrectly	Enter correct process target
					Entered tolerance incorrectly	Enter correct tolerance
					Requested volume incorrectly	Check automation program
					Automation problem	Verify automation is correct
WND_	51	Fluid Plate Key Token Error	Missing or invalid key token	Alarm	FCM key token is required to run system	Verify FCM key token is installed Verify FCM key token is correct part number
P6D_	52	Outlet Pressure Transducer Error	Outlet pressure transducer error	Alarm	Problem detected with outlet pressure transducer	Verify outlet pressure transducer is installed and/or connected correctly Replace if necessary
P6F_	53	Inlet Pressure Transducer Error	Inlet pressure transducer error	Advisory	Problem detected with inlet pressure transducer	Verify inlet pressure transducer is installed and/or connected correctly Replace if necessary
F6D_	54	Flow Meter Error	Flow Meter error	Alarm	Problem detected with flow meter	Verify flow meter is installed and/or connected correctly Replace if necessary

Event Code	Gateway Error No.	Event Name	Event Description	Event Type	Cause	Solution
Fluid Plate Events and Errors						
WED_	55	V/P Error	Voltage to Pressure Transducer error	Alarm	Problem detected with V/P	Verify outlet pressure transducer is installed and/or connected correctly Replace if necessary
WJ1_	56	Dispense Valve 1 Error	Dispense valve 1 error	Alarm	Problem detected with dispense valve 1	Verify dispense valve 1 is installed and/or connected correctly Replace if necessary
WJ2_	57	Dispense Valve 2 Error	Dispense valve 2 error	Alarm	Problem detected with dispense valve 2	Verify dispense valve 2 is installed and/or connected correctly Replace if necessary
WJ3_	58	Dispense Valve 3 Error	Dispense valve 3 error	Alarm	Problem detected with dispense valve 3	Verify dispense valve 3 is installed and/or connected correctly Replace if necessary
WJ4_	59	Dispense Valve 4 Error	Dispense valve 4 error	Alarm	Problem detected with dispense valve 4	Verify dispense valve 4 is installed and/or connected correctly Replace if necessary
WSD_	60	Incompatible Valve Settings	Incompatible settings for multiple valve operation; attempted to dispense	Alarm	Attempted to dispense simultaneously from multiple valves on the same fluid plate with different pressure settings	Check settings shown on Fluid Plate x, screen 2 (Mode Settings) Verify automation programming
WSD5	60	Incompatible Valve Settings	Incompatible settings for multiple valve operation; attempted to dispense	Alarm	Attempted to dispense simultaneously from multiple valves on the same fluid plate with different pressure settings	In the Discrete Gateway screens, change the settings of the simultaneously dispensing valves to the same pressure Verify automation programming
F7D_	61	Closed Valve Flow	System reading flow meter pulses with valve(s) closed	Alarm	Dispense hose leak	Check hose; replace if needed
					Flow meter providing false pulses	Replace flow meter sensor or calibrate meter
					Dispense valve not operating correctly	Repair dispense valve

Event Code	Gateway Error No.	Event Name	Event Description	Event Type	Cause	Solution
Fluid Plate Events and Errors						
V2D_	62	Low Analog	Command cable analog command dropped below minimum value of 1 V while dispensing	Deviation	Bad or loose command cable connection	Check command cable and connection
					Entered command mode incorrectly	Enter correct command code
					Automation program error	Verify correct automation program
WFD_ WFG_	63	Flow Meter Required	Operating mode requires flow meter. Advisory is issued if fluid plate settings require a flow meter but meter is not present. Alarm is issued if dispense is attempted in mode that requires a flow meter but meter is not present.	Alarm or Advisory (self-clearing)	Selected valve mode settings require flow meter	Check valve mode settings Purchase meter enabled token for FCM and install flow meter
					FCM key token missing or invalid	Check for FCM key token error
EJD_	64	Job Cycle Time Out	Job cycle time out	Alarm	Automation signals did not properly end job cycle	Check automation programming per job operating instruction
WXD_	65	Fluid Plate Error Detected	Fluid plate error detected; includes any error not covered by another more specific error	Alarm	Analog voltage applied to pin 1 of the command cable exceeds 10 Vdc.	Limit signal on pin 1 of command cable to the range of 0-10 Vdc.
					Failed FCM	Replace FCM if necessary
P3F_ P4F_	66	Maximum Inlet Pressure	Inlet pressure to regulator is above upper limit set for operation	Alarm or Deviation (user selectable)	Incorrect set limit	Verify limit is set correctly
					Material supply pressure is too high	Decrease material supply pressure
					Failed transducer	Check transducer; replace if necessary
P3D_ P4D_	67	Maximum Outlet Pressure	Outlet pressure of regulator is above upper limit set for operation	Alarm or Deviation (user selectable)	Incorrect set limit	Verify limit is set correctly
					Material supply pressure is too high	Decrease material supply pressure
					Failed transducer	Check transducer; replace if necessary
P1F_ P2F_	68	Minimum Inlet Pressure	Inlet pressure to regulator is below lower limit set for operation	Alarm or Deviation (user selectable)	Incorrect set limit	Verify limit is set correctly
					Material supply pressure is too low	Increase crease material supply pressure
					Failed transducer	Check transducer; replace if necessary

Event Code	Gateway Error No.	Event Name	Event Description	Event Type	Cause	Solution
Fluid Plate Events and Errors						
P1C_ P2C_	69	Low Pressure	Measured outlet pressure less than desired outlet pressure minus tolerance	Alarm or Deviation (user selectable)	Incorrect limit set	Verify limit is set correctly
					No or insufficient material flow	Increase material flow rate
					Dispense valve needle is stuck closed	Dislodge and inspect needle
					Dispense valve leaking	Repair dispense valve
					Regulator not operating correctly	Repair regulator
					Pump wink passed through outlet	Increase pump pressure
					Failed transducer	Check transducer; replace if failed
P3C_ P4C_	70	High Pressure	Measured outlet pressure greater than desired outlet pressure plus tolerance	Alarm or Deviation (user selectable)	Incorrect limit set	Verify limit is set correctly
					Dispense hose/device plugged	Clean/replace hose/device
					Failed transducer	Check transducer; replace if failed
					Regulator is not closing completely when it should	Repair regulator
F1D_ F2D_	71	Low Flow Rate	Measured flow rate less than desired flow rate minus tolerance	Alarm or Deviation (user selectable)	Fluid supply too low to achieve desired flow rate	Increase fluid supply pressure or check for clogged filter
					Tip plugged	Clean/replace tip
					No air pressure to solenoid valves	Turn on air to solenoid valves
					No flow meter signal	Check cable and sensor
					No material supply	Replace drum or turn on pumps
					Incorrect flow tolerance of flow error time	Enter correct tolerance or flow error time
F3D_ F4D_	72	High Flow Rate	Measured flow rate greater than desired flow rate plus tolerance	Alarm or Deviation (user selectable)	Operating below minimum regulator operating pressure	Increase fluid pressure above regulator minimum
					Regulator worn or not operating correctly	Repair regulator
					Flow meter providing false pulses	Replace flow meter sensor
					Incorrect flow error tolerance or flow error time	Enter correct tolerance or flow error time
EKD_	73	Shot Terminated by Job Timer	Shot dispense cycle terminated by job timer	Advisory	Job end timer was used to stop shot dispense	No action required if timed shot is desired
EHD_	74	Purge Timer Expired	Purge timer expired	Advisory	PCF purge timer (style 0) has expired	Automation control requests purge

Event Code	Gateway Error No.	Event Name	Event Description	Event Type	Cause	Solution
Fluid Plate Events and Errors						
EAC_	75	Maintenance Mode Entered	Maintenance mode entered	Advisory (self-clearing)	Entered maintenance dispense mode	No action required
EBC_	76	Maintenance Mode Exited	Maintenance mode exited	Advisory (self-clearing)	Exited maintenance dispense mode	No action required
MHD_	77	Maintenance Due - Regulator	Maintenance due for regulator	Advisory	Totalizer exceeded limit setting	Service component If necessary, reset totalizer
MFD_	78	Maintenance Due - Flow Meter	Maintenance due for flow meter	Advisory	Totalizer exceeded limit setting	Service component If necessary, reset totalizer
MED_	79	Maintenance Due - V/P	Maintenance due for Voltage to Pressure Transducer	Advisory	Totalizer exceeded limit setting	Service component If necessary, reset totalizer
MCD_	80	Maintenance Due - Supply	Maintenance due for supply system	Advisory	Totalizer exceeded limit setting	Service component If necessary, reset totalizer
MD1_	81	Maintenance Due - Valve 1	Maintenance due for valve 1	Advisory	Totalizer exceeded limit setting	Service component If necessary, reset totalizer
MD2_	82	Maintenance Due - Valve 2	Maintenance due for valve 2	Advisory	Totalizer exceeded limit setting	Service component If necessary, reset totalizer
MD3_	83	Maintenance Due - Valve 3	Maintenance due for valve 3	Advisory	Totalizer exceeded limit setting	Service component If necessary, reset totalizer
MD4_	84	Maintenance Due - Valve 4	Maintenance due for valve 4	Advisory	Totalizer exceeded limit setting	Service component If necessary, reset totalizer
CCD_	85	Duplicate Module	Duplicate Fluid Control Module Detected	Alarm	Two or more FCMs have the same rotary switch setting	Verify that all FCMs have proper rotary switch settings. Reset module after changing rotary switch setting. Refer to Fluid Plate Assembly Overview section, page 14
EAD_	86	Swirl Maintenance Mode Entered	Swirl maintenance mode entered	Advisory (self-clearing)	Swirl zone that is associated with this fluid plate entered maintenance mode	No action required
WFC_	87	Shot No-Flow Timeout	No flow detected for five seconds on valve activated in shot mode	Alarm	Dispense valve not operating properly	Check dispense valve for correct operation and/or clogging
					Fluid leak	Check fluid connections

Event Code	Gateway Error No.	Event Name	Event Description	Event Type	Cause	Solution
Fluid Plate Events and Errors						
CR1_	88	Valve 1 Swirl Communication Error	Fluid plate communication error with swirl	Alarm	The fluid plate lost communication with the swirl zone associated with this valve and fluid plate	Restore communications.
CR2_	89	Valve 2 Swirl Communication Error	Fluid plate communication error with swirl	Alarm	The fluid plate lost communication with the swirl zone associated with this valve and fluid plate	Restore communications.
CR3_	90	Valve 3 Swirl Communication Error	Fluid plate communication error with swirl	Alarm	The fluid plate lost communication with the swirl zone associated with this valve and fluid plate	Restore communications.
CR4_	91	Valve 4 Swirl Communication Error	Fluid plate communication error with swirl	Alarm	The fluid plate lost communication with the swirl zone associated with this valve and fluid plate	Restore communications.
WD1_	92	Valve 1 Swirl Fault	Swirl motor fault	Alarm or Deviation (user-selectable)	The swirl zone associated with this valve and fluid plate caused a fault	Resolve swirl motor fault (see error WBDX for possible solutions)
WD2_	93	Valve 2 Swirl Fault	Swirl motor fault	Alarm or Deviation (user-selectable)	The swirl zone associated with this valve and fluid plate caused a fault	Resolve swirl motor fault (see error WBDX for possible solutions)
WD3_	94	Valve 3 Swirl Fault	Swirl motor fault	Alarm or Deviation (user-selectable)	The swirl zone associated with this valve and fluid plate caused a fault	Resolve swirl motor fault (see error WBDX for possible solutions)
WD4_	95	Valve 4 Swirl Fault	Swirl motor fault	Alarm or Deviation (user-selectable)	The swirl zone associated with this valve and fluid plate caused a fault	Resolve swirl motor fault (see error WBDX for possible solutions)
MB1_	96	Maintenance due - V1 Orbiter	Maintenance due on valve 1 swirl orbiter	Advisory	The active time totalizer for the swirl dispenser associated with this valve and fluid plate exceeded limit setting	Service Component If necessary, reset totalizer
MB2_	97	Maintenance due - V2 Orbiter	Maintenance due on valve 2 swirl orbiter	Advisory	The active time totalizer for the swirl dispenser associated with this valve and fluid plate exceeded limit setting	Service Component If necessary, reset totalizer

Event Code	Gateway Error No.	Event Name	Event Description	Event Type	Cause	Solution
Fluid Plate Events and Errors						
MB3_	98	Maintenance due - V3 Orbiter	Maintenance due on valve 3 swirl orbiter	Advisory	The active time totalizer for the swirl dispenser associated with this valve and fluid plate exceeded limit setting	Service Component If necessary, reset totalizer
MB4_	99	Maintenance due - V4 Orbiter	Maintenance due on valve 4 swirl orbiter	Advisory	The active time totalizer for the swirl dispenser associated with this valve and fluid plate exceeded limit setting	Service Component If necessary, reset totalizer

Swirl Events and Errors

Event Code	Gateway Error No.	Event Name	Event Description	Event Type	Cause	Solution
Swirl Events and Errors						
CBR_	---	Swirl Communication Error	Swirl communication error with ADM	Alarm	The ADM lost communication with the Swirl Control DGM	Restore communications
CDR_	---	Duplicate Module	Duplicate Swirl Control DGM Detected	Alarm	Two or more Swirl Control DGMs have the same rotary switch setting	Verify that all Swirl Control DGMs have proper rotary switch settings. Reset module after changing rotary switch setting. Refer to Swirl Control DGM section, page 19.
EAD_	---	Maintenance Mode Entered	Maintenance mode entered	Advisory (self-clearing)	Swirl maintenance mode entered	No action required
EBD_	---	Maintenance Mode Exited	Maintenance mode exited	Advisory (self-clearing)	Swirl maintenance mode exited	No action required
MBD_	---	Maintenance Due - Orbiter	Maintenance due on swirl orbiter	Advisory	Swirl active time totalizer exceeded limit setting	Service Component If necessary, reset totalizer
WBD_	---	Swirl Motor Fault	Motor speed is outside the +/- 50% tolerance range for at least 5 seconds while operating	Alarm	Cable disconnected	Verify cable connections to swirl board, swirl motor cable, and swirl orbiter
					Shorted motor cable (amber LED on swirl board will be on)	Replace swirl motor cable (55 ft)
					Orbiter bearing failure	Replace bearing
					Motor defective	Replace swirl orbiter

Maintenance

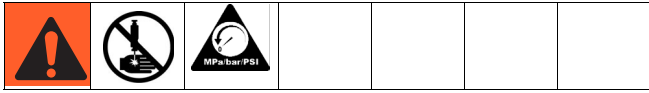

Prior to performing any maintenance procedures, follow the **Pressure Relief Procedure** on page 57.

Maintenance Schedule

The following tables list the recommended maintenance procedures and frequencies to operate the equipment safely. The maintenance is divided between mechanical and electrical tasks. Maintenance must be performed by trained personnel per this schedule to assure safety and reliability of the equipment.

Mechanical

Task	Operator		Maintenance Person				
	Daily	Weekly	Monthly	3-6 months or 125,000 cycles	18-24 months or 500,000 cycles	36-48 months or 1,000,000 cycles	7000 hours
Inspect system for leaks	✓						
Depressurize fluid, after operation	✓						
Remove heat from system, after operation	✓						
Inspect filter (234967) bowls and drain		✓					
Check hoses for wear		✓					
Check/tighten fluid connections		✓					
Check/tighten air connections		✓					
Lubricate dispense valves*			✓				
Rebuild regulator*				✓			
Rebuild dispense valve*				✓			
Replace air filter					✓		
Replace Solenoid						✓	
Replace Voltage to Pressure (V/P) Transducer							✓

* Check component manual for more detailed maintenance information.

Electrical

Task	Weekly
Check cables for wear	✓
Verify cable connections	✓
Verify operation of "System Stop" button	✓

* Check Component Manual for more detailed maintenance information.

Advanced Display Module (ADM)

Upgrade Software

NOTE: Back up the custom language file (if installed) before upgrading software. See **USB Data**, page 59, for more information.

1. Turn off power to the system.
2. Remove token access panel, and then remove the key token (do not discard token).

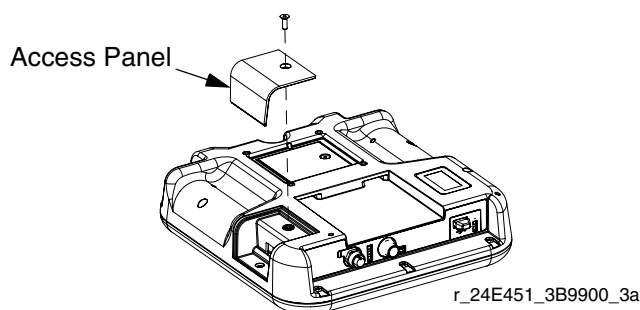

FIG. 41: Remove Access Panel

3. Insert and press software token firmly into slot.

NOTE: There is no preferred orientation of token.

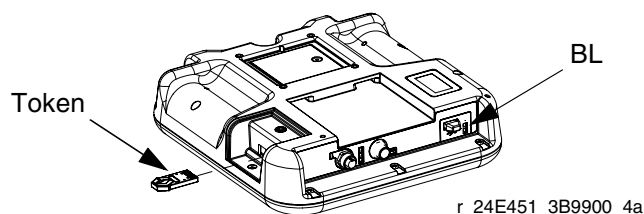

FIG. 42: Insert Token

4. Turn on power to the system. The red indicator light (BL) will flash until new software is completely loaded.
5. After the red indicator light shuts off, turn off power to the system.
6. Remove software token.
7. Reinstall key token, and replace token access panel.

Cleaning

Use any alcohol-based household cleaner, such as glass cleaner, to clean the display.

Upgrade Gateway Module Software

NOTE: The Gateway module connection to the system is temporarily disabled during the use of upgrade tokens. The following instructions apply to all Gateway modules.

1. Turn off power to the system.
2. Remove the access cover.

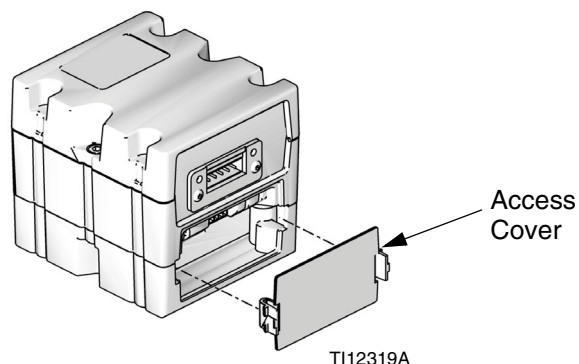

FIG. 43: Remove Access Cover

3. Insert and press token firmly into slot.

NOTE: There is no preferred orientation of token.

4. Turn on power to the system. The red indicator light (CK) will flash until new software is completely loaded.

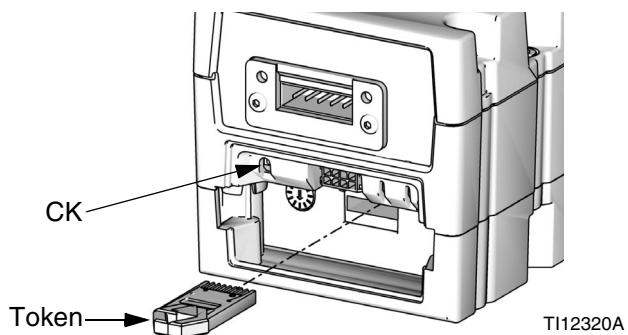

FIG. 44: Insert Token

5. After the red indicator light shuts off, turn off power to the system.
6. Remove token.
7. Replace access cover.

Upgrade Gateway Module Fieldbus Map

NOTE: The fieldbus connection is temporarily disabled during the use of a map token. The following instructions apply to all Gateway modules.

1. Perform **Upgrade Gateway Module Software**. Software must be upgraded before upgrading the fieldbus map.
2. Remove the access cover.

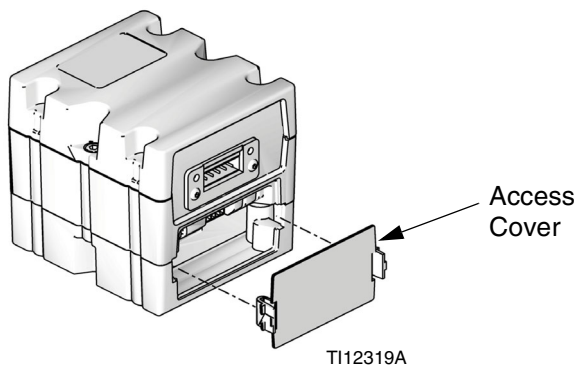

FIG. 45: Remove Access Cover

3. Insert and press map token firmly into slot.

NOTE: There is no preferred orientation of the token.

4. Press and hold the push button for three seconds and then release. The red indicator light (CK) will flash twice, pause, and then once after the data map is uploaded.

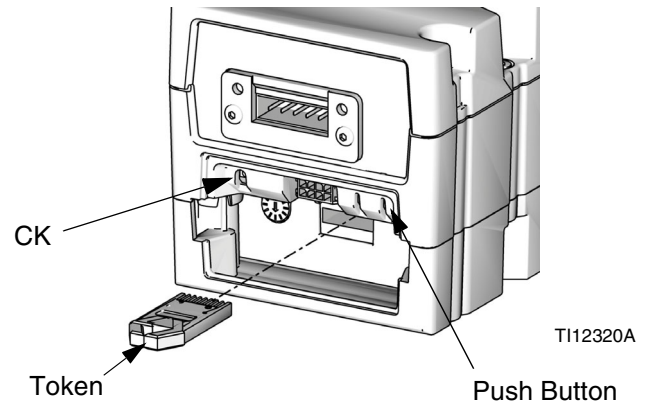

FIG. 46: Insert Token

5. Remove map token (CC) when software has successfully uploaded.
6. Replace access cover.

Upgrade Fluid Control Module (FCM) Software

NOTE: The FCM connection is temporarily disabled during the use of the upgrade token.

1. Turn off power to the system.
2. Remove access cover then remove key token (do not discard token).

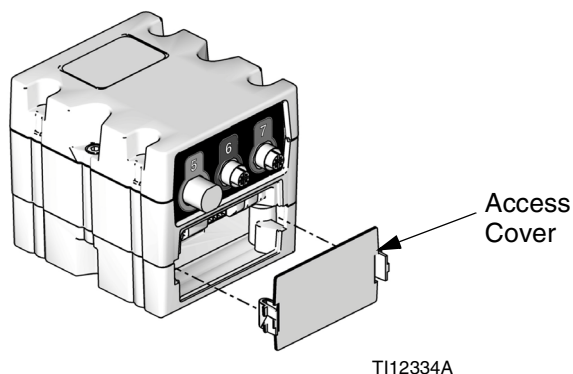

FIG. 47: Remove Access Cover

3. Insert and press software token firmly into slot.

NOTE: There is no preferred orientation of token.

4. Turn on power to the system. The red indicator light (CK) will flash until new software is completely loaded.

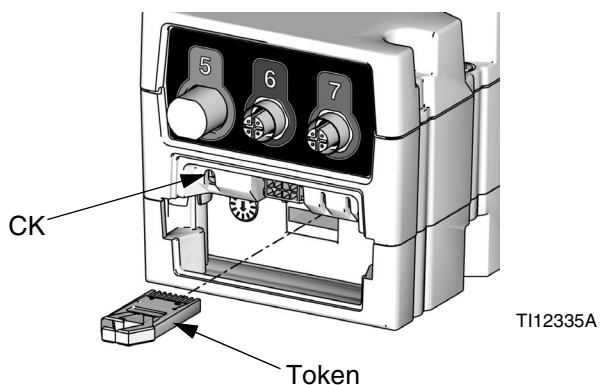

FIG. 48: Insert Token

5. After the red indicator light shuts off, turn off power to the system.
6. Remove software token.

7. Reinstall key token, and replace access cover.

Air Filter Maintenance

To prevent filter element damage, replace air filter every two years or when pressure drop becomes 100 kPa (1.0 bar, 14.5 psi) or greater; whichever occurs first.

Replacement Air Filters for Dual Filter Assembly (234967)

Part	Description
123091	5 micron air filter
123092	0.3 micron air filter

Swirl Dispensers

See manual 309403 for maintenance schedule.

Repair

Fluid Plate Assembly



This section describes how to remove and replace components on the fluid plate assembly.

Prepare Fluid Plate Assembly for Repair

1. Disconnect the CAN cable from the fluid plate.
2. Perform **Pressure Relief Procedure** on page 57.
3. Remove the fluid plate assembly shroud. See **Fluid Plate Assembly Parts**, page 94.

Repair Flow Meter

For complete flow meter (129) repair instructions refer to the maintenance and repair section of manual 309834.

Remove Flow Meter from Mounting Plate

1. **Prepare Fluid Plate Assembly for Repair**, page 80.
2. Disconnect the flow meter cable (131) from the flow meter sensor. See FIG. 49.
3. Disconnect the material hose.
4. Disconnect the swivel fitting (109) from the regulator.
5. Loosen the four screws (127) and washers (125, 126); remove the bracket (124) and flow meter (129).
6. The flow meter weighs approximately 15 lbs. (6.75 kg). Carefully lift it off the mounting plate (101).

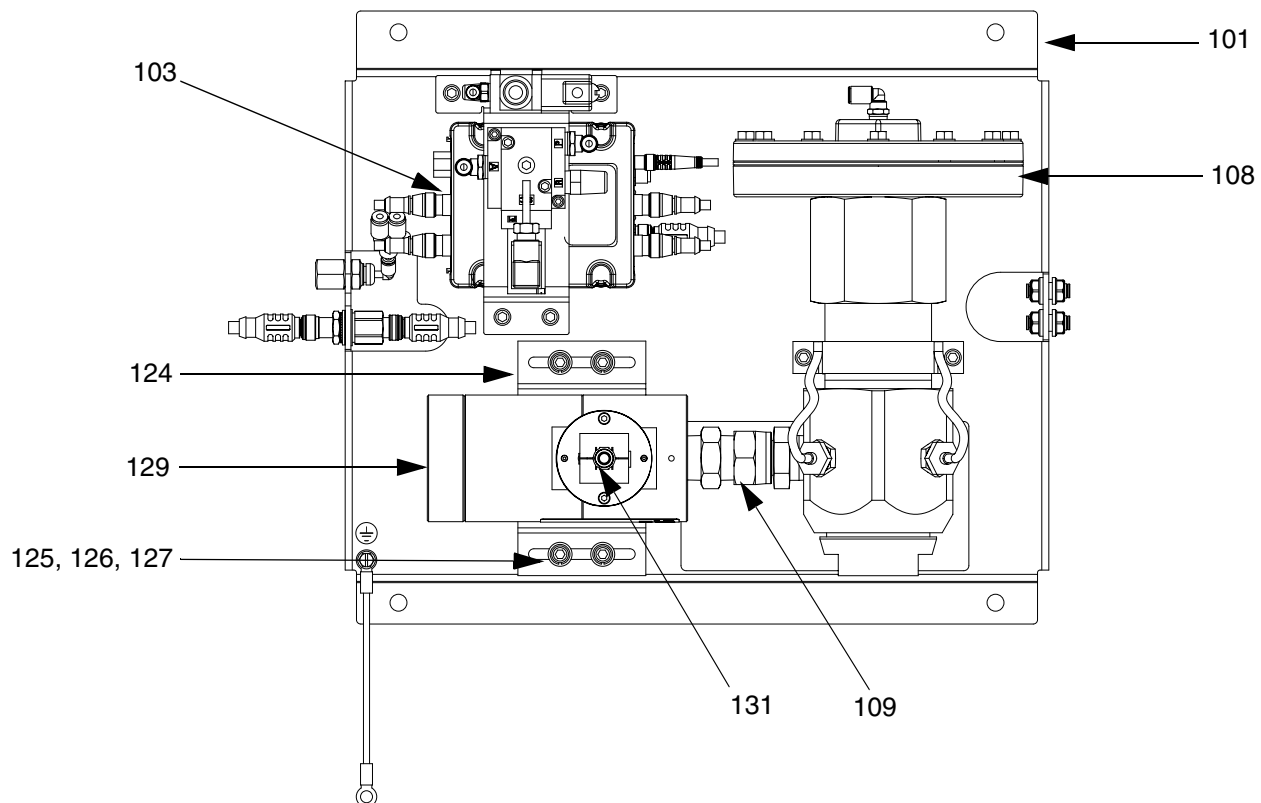

r_pf0000_313377_18a

FIG. 49: Fluid Plate Assembly

Install Flow Meter on Mounting Plate

1. Rest the flow meter (129) and bracket (124) on the fluid plate while threading the swivel fitting (109) onto the regulator material inlet. See FIG. 49.
2. Tighten the swivel fitting to the regulator material inlet.
3. Tighten the four screws (127) and washers (125, 126) to hold the bracket and flow meter in place.

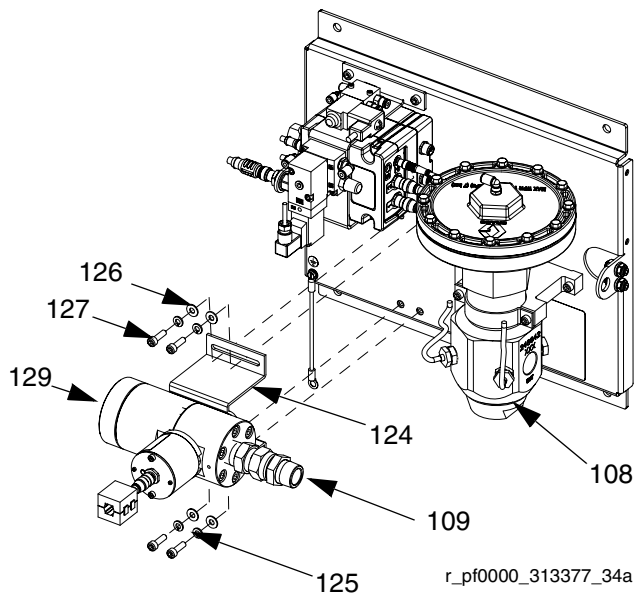

FIG. 50

4. Check that the flow meter and regulator (108) are still aligned.
5. Connect the material hose.
6. Connect the flow meter cable (131).

Replace Solenoid

1. Prepare Fluid Plate Assembly for Repair, page 80.
2. Disconnect FCM cable and all three air tubes.
3. Remove both screws (137) from transducer bracket (118).

4. Remove the dispense valve solenoid (132) and replace it with a new solenoid.

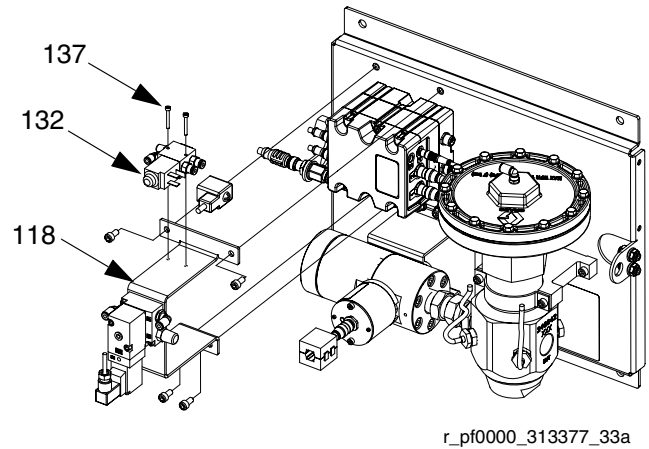

FIG. 51

5. Secure the new solenoid to the bracket with screws.
6. Reconnect the FCM cable and all three air tubes.

Replace Voltage to Pressure (V/P) Transducer

1. Prepare Fluid Plate Assembly for Repair, page 80.
2. Disconnect the FCM cable and both air tubes.
3. Remove both transducer screws (122) from transducer bracket (118).
4. Remove the V/P transducer (121) and replace it with a new V/P transducer.

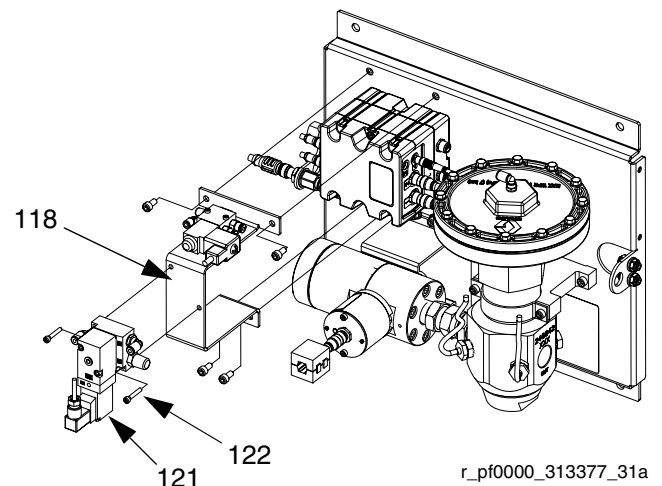

FIG. 52

5. Secure the new V/P transducer to the bracket with screws.
6. Reconnect the FCM cable and both air tubes.

Replace Fluid Control Module

1. **Prepare Fluid Plate Assembly for Repair**, page 80.
2. Remove the four screws (128) from the transducer bracket (118), and remove the bracket. (Leave the dispense valve solenoid (132) and V/P transducer (121) attached to the transducer bracket.)

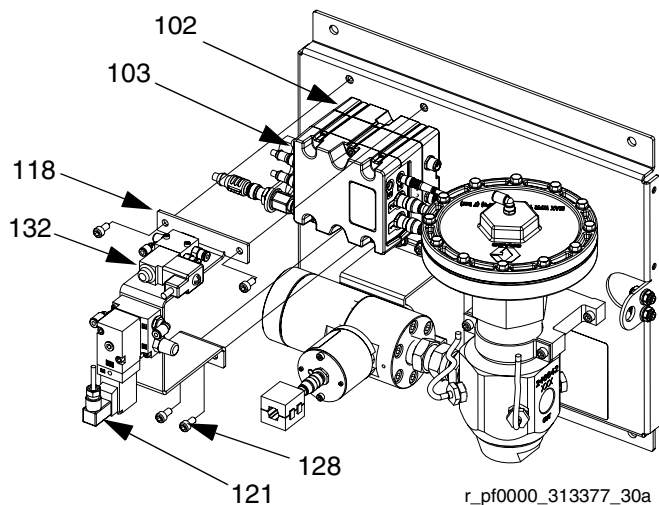

FIG. 53

3. Remove the following cables from FCM:
 - dispense valve solenoid cable
 - meter sensor cable
 - both V/P cables
 - I/O cable
 - inlet pressure transducer cable (ambient models only)
 - outlet pressure transducer cable
4. Remove the two screws from FCM (103) and replace with a new FCM.
5. Secure the new FCM to the base (102) with screws.
6. Reconnect the cables listed in step 3.
7. Reattach the transducer bracket using screws.

Replace Fluid Control Module Base

1. **Prepare Fluid Plate Assembly for Repair**, page 80.
2. Remove the FCM (103); follow **Replace Fluid Control Module**. (Leave the cables attached to the FCM.)
3. Remove the power supply cable from the base (102).
4. Remove the four screws (105) and ground screw (106) from the base and replace it with a new base.

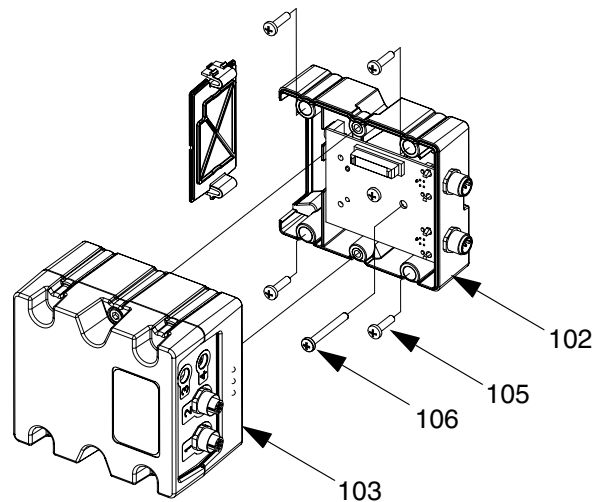

FIG. 54

5. Secure the base to the fluid plate (101) with screws.
6. Reconnect the power supply cable.
7. Reattach the FCM; follow **Replace Fluid Control Module**.

Replace Transducer O-Rings

1. Prepare Fluid Plate Assembly for Repair, page 80.
2. Remove the fluid outlet pressure sensor (117) from the regulator (108).

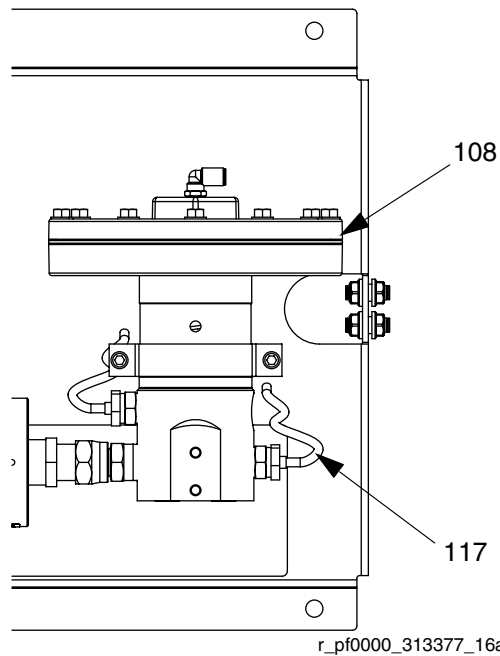

FIG. 55

3. Press the transducer (CG) out of the retainer nut (CH).
4. Remove the faulty o-ring (120) and replace with new.

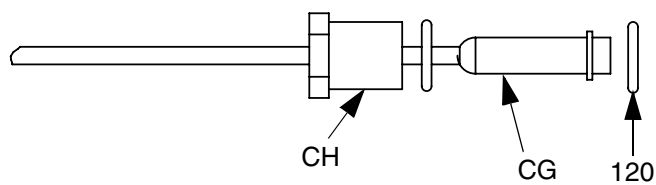

FIG. 56

5. Press the transducer back into the retainer nut.
6. Reconnect the fluid outlet pressure sensor to the regulator.

Repair Fluid Regulator

For complete cartridge fluid regulator repair refer to instruction manual 308647. For complete mastic fluid regulator repair refer to instruction manual 307517.

See FIG. 57 and perform the following steps.

NOTICE

Carefully handle the hard carbide ball, valve actuator, and valve seat to avoid damaging them.

1. **Prepare Fluid Plate Assembly for Repair**, page 80.
2. Remove the cartridge assembly by loosening the valve housing (CE) with a 6 mm hex wrench and pulling the cartridge assembly out of the base housing (CD).

NOTE: The retaining nut (CC) often loosens when removing the cartridge assembly from the base housing. Be sure to re-torque as described in step 4.

3. Inspect and clean the internal walls of the base housing (CD).

NOTE: Be careful to not scrape or gouge the internal walls of the base housing. They are a sealing surface.

4. Re-torque the retaining nut (CC) to 140-160 in-lb (16-18 N•m).

NOTE: You must re-torque the retaining nut before you install it in the base housing during step 5.

5. Install the new cartridge assembly in the base housing (CD), and torque the valve housing (CE) to 30-35 ft-lb (41-48 N•m).

NOTE: The valve seat is double sided and may be reversed for extended life. The o-ring and ball must be replaced. See instruction manual 308647.

Cartridge Regulator 244734 Shown

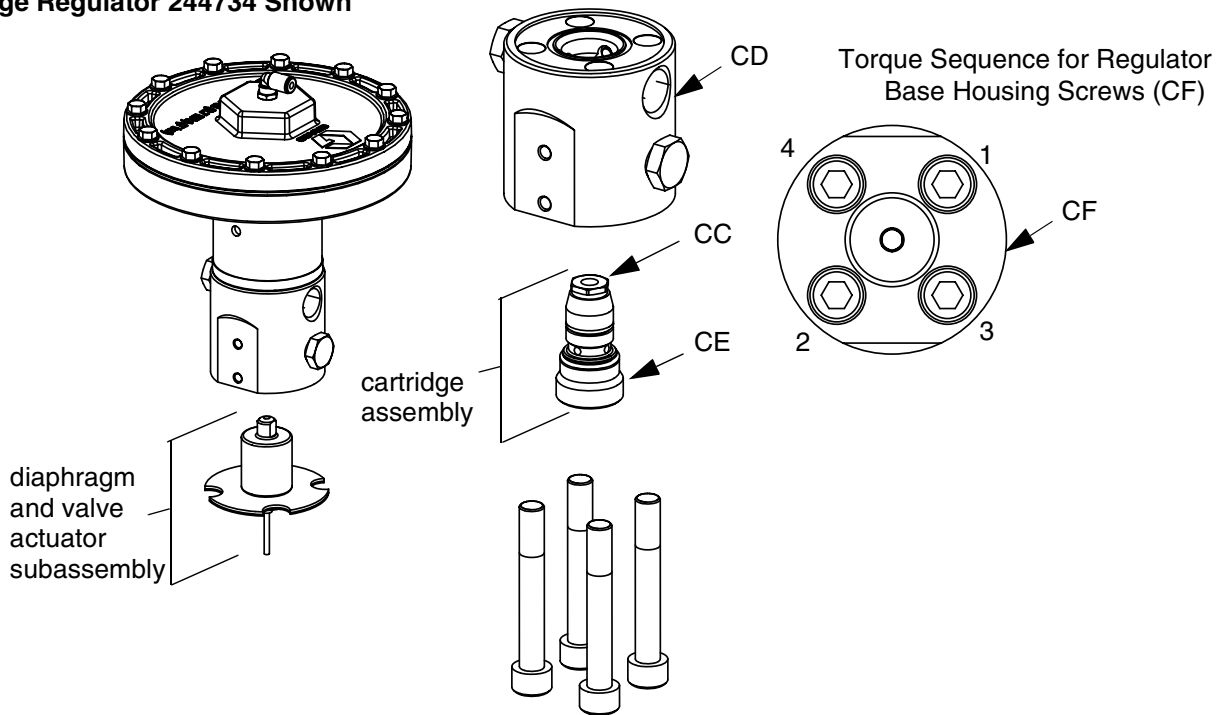

FIG. 57: Replace Cartridge Assembly

Replace Amplifier

(Heated fluid plates only)

1. **Prepare Fluid Plate Assembly for Repair**, page 80.
2. Disconnect pressure sensor cable (117) and power output cable.

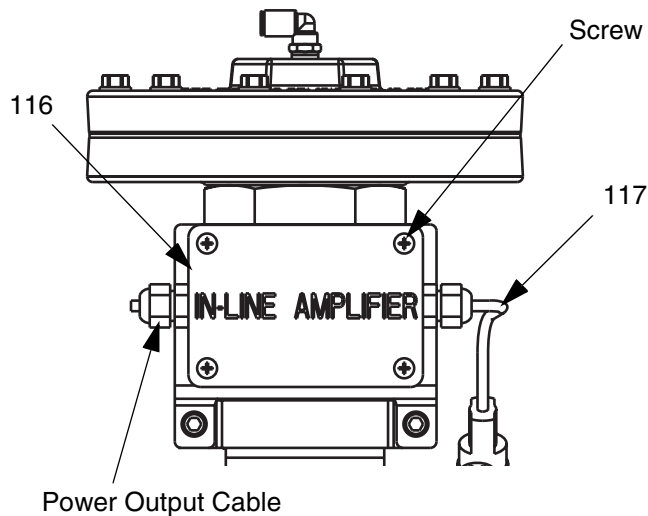

FIG. 58: Replace Amplifier

3. Loosen four screws on amplifier (116) cover, and then remove cover.
4. Remove four screws (105) securing amplifier to bracket.
5. Remove amplifier and replace with a new amplifier.
6. Secure new amplifier to bracket with four screws.
7. Replace amplifier cover and tighten screws.
8. Reconnect pressure sensor cable (117) and power output cable.

Calibrate Amplifier

(Heated fluid plates only)

1. **Prepare Fluid Plate Assembly for Repair**, page 80.
2. Remove outlet pressure sensor from outlet fitting to ensure there is no pressure applied to the sensor.

Adjust Display Settings

3. With the system in setup mode, navigate to the Advanced screens.

4. Press to scroll to Advanced screen 2.

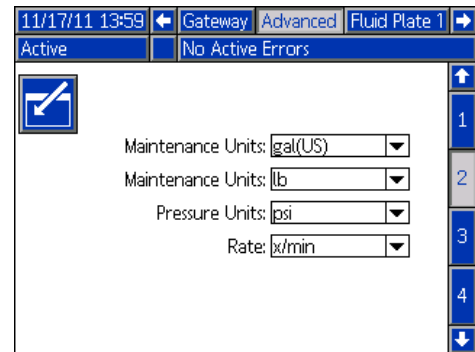

5. Press to access the fields to make changes.
6. Press to move the Pressure Units field. Press to open the drop-down list, and select psi. Press to enter the new units.

7. Press to exit edit mode.

8. With the system still in setup mode, navigate to Fluid Plate x, screen 5 (Pressure Sensors).

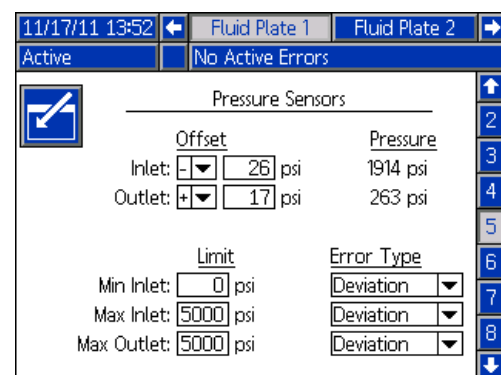

9. Press to access the fields to make changes.
10. Press to move the Outlet Offset field. Set the psi to 0. Press to enter the new setting.
11. Press to exit edit mode.

Adjust Amplifier Settings

12. Remove cover from amplifier (116). See **Replace Amplifier**, page 85.
13. Ensure the EXCITATION SELECTOR jumper is in the middle position (5 Vdc). See FIG. 59 on page 86.
14. Ensure the COARSE GAIN dipswitch 1 is set to ON. All others should be set to OFF.
15. Adjust the FINE ZERO potentiometer until the outlet pressure on the display reads 0.
16. Use a small piece of jumper wire or a paper clip to connect the SHUNT CAL and ENABLE terminals.

17. Use the data from the certificate of calibration for the pressure sensor (included with PCF documentation or the replacement pressure sensor) to calculate the Shunt Calibration Pressure using the following formula:

$$\text{Shunt Calibration Pressure} = (\text{Shunt Cal Factor} / \text{Calibration Factor}) * 5000 \text{ psi}$$
18. Adjust the FINE GAIN potentiometer until the Outlet Pressure on Fluid Plate x, screen 5 (Pressure Sensors) matches the calculated Shunt Calibration Pressure.
19. Remove the jumper wire or paper clip from the SHUNT CAL and ENABLE terminals.
20. Repeat steps 15 - 19 at least one additional time to ensure proper calibration.

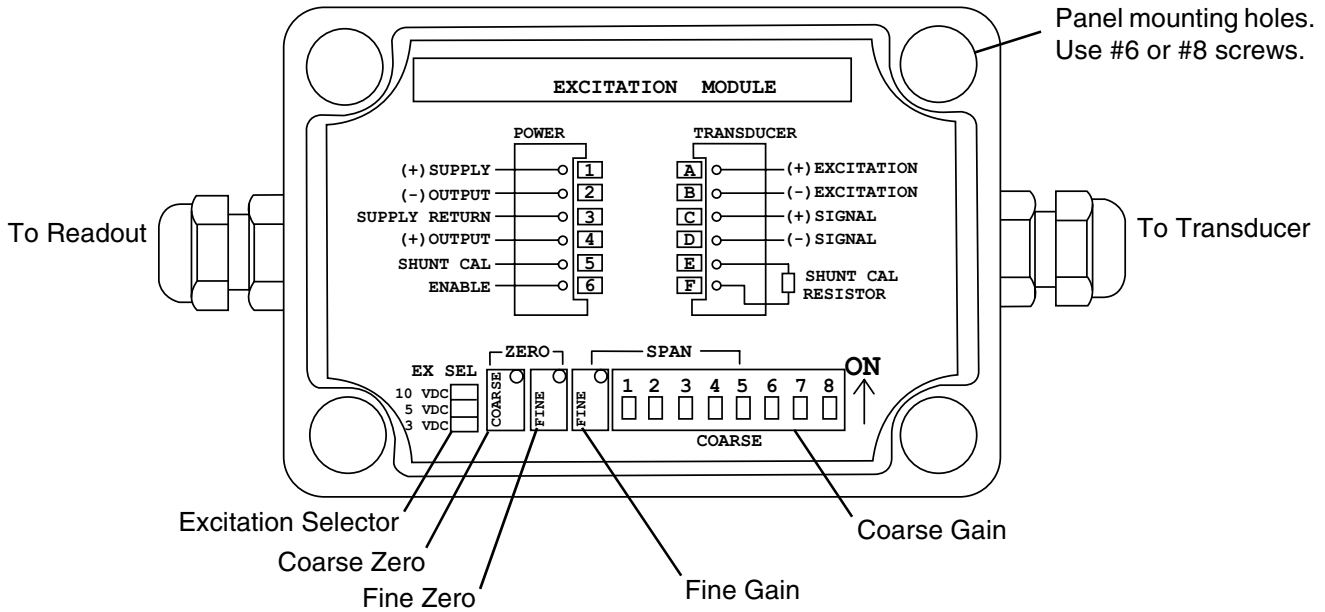
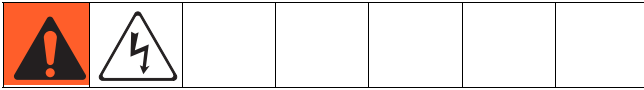

FIG. 59: Amplifier Settings

21. Replace the amplifier cover. See **Replace Amplifier**, page 85.
22. Reconnect the outlet pressure sensor cable if it was removed.
23. If desired, change pressure units to desired setting on Advanced screen 2.

Control Center Assembly



Prepare Control Center for Repair

1. Power off the display.
2. Disconnect main power to the control center assembly.
3. Remove the control center assembly front cover (20).

Replace Gateway Module

1. Prepare Control Center for Repair, page 87.
2. Remove the automation communications cable (AE).
3. Remove the two screws holding the Gateway module (5) to the base (3), and remove the module.

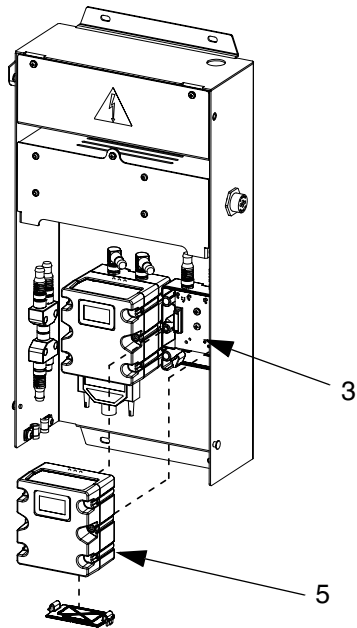

FIG. 60

4. Attach a new Gateway module to the base using two screws.
5. Reconnect the automation interface cable.
6. Upgrade software, page 77, then upgrade fieldbus map, page 78.

Replace Gateway Module Base

1. Prepare Control Center for Repair, page 87.
2. Remove the Gateway module (5); follow **Replace Gateway Module**. (Leave automation communications cable (AE) attached to Gateway module.)
3. Disconnect the CAN cable (19) and power supply cable (6) from the base (3).
4. Remove the four screws (16) and grounding screw (12) from the base and replace it with a new base.

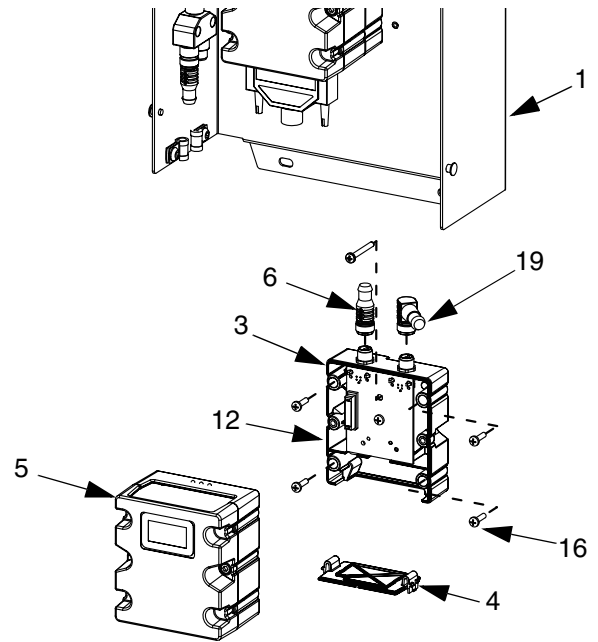

FIG. 61

5. Secure the new base to rear cover (1) using the five screws.
6. Reattach Gateway module; follow **Replace Gateway Module**.

Replace Swirl Board 16K570:

1. **Prepare Control Center for Repair**, page 87.
2. Remove screw (a) from swirl board cover. Open swirl board cover.
3. Remove cable connectors (b) from swirl board.
4. Remove the four screws (c) from the swirl board. Replace with new board and secure using the four screws (c).
5. Insert cable connectors (b) into the new board.
6. Reassemble the swirl board cover using screw (a).

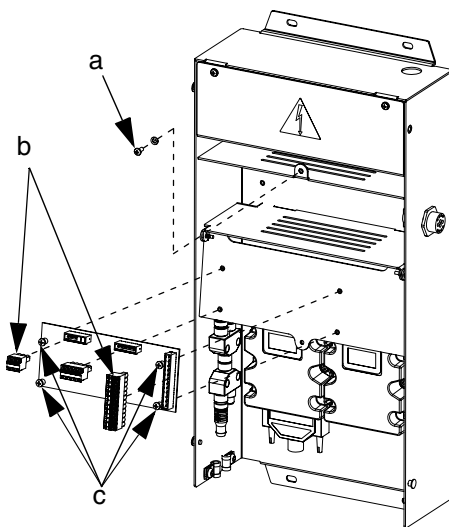

FIG. 62

Replace Advanced Display Module

1. **Prepare Control Center for Repair**, page 87.
2. Disconnect the CAN cable (18) from the ADM (2).

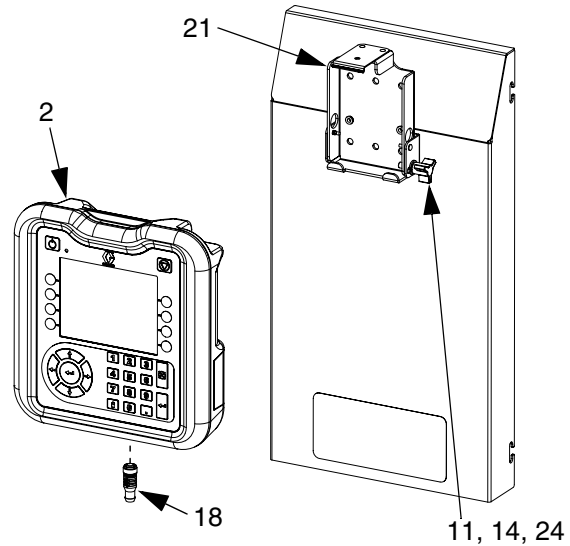

FIG. 63

3. Remove the ADM by snapping it out of the mounting bracket.
4. On old ADM, remove token access panel then remove key token. Do not discard token.
5. Connect the CAN cable to the new ADM.
6. Upgrade new ADM software, page 77.
7. Insert key token into new ADM. Replace token access panel.
8. Install the new ADM by snapping it into the mounting bracket.

Replace Advanced Display Module Bracket

1. **Prepare Control Center for Repair**, page 87.
2. Remove the ADM (2); follow **Replace Advanced Display Module**. (Leave the CAN cable attached to the ADM.)
3. Remove the speed clips (25) and rivets (26) from the mounting bracket (21).

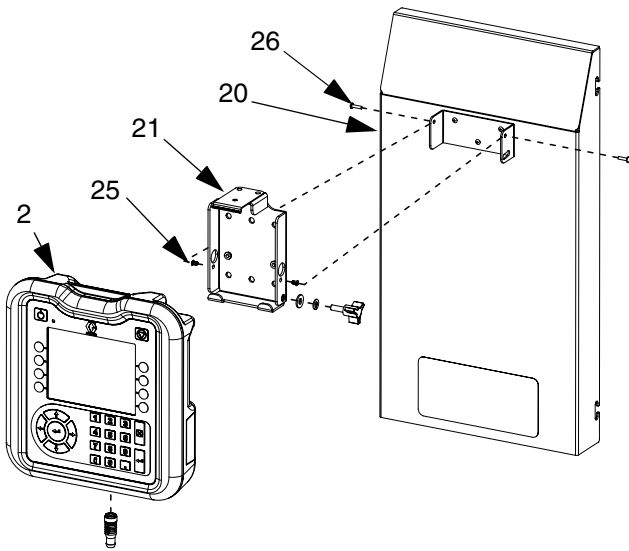

FIG. 64

4. Remove the mounting bracket from the front cover (20) and replace with a new bracket.
5. Secure the new bracket to the front cover with speed clips and rivets.
6. Reinstall the ADM.

Replace DIN Rail Assembly

1. **Prepare Control Center for Repair**, page 87.
2. Remove both screws (22) and washers (28) from the line voltage assembly cover (7). Remove the cover.

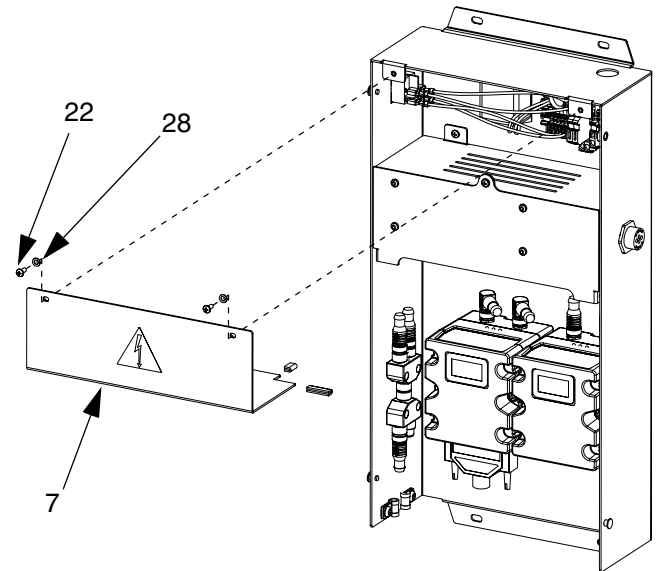

FIG. 65

3. Disconnect all wiring from the din rail module and filter.
4. Remove the four screws (40) from the din rail and filter.
5. Disconnect wires from rocker/rotary switch. Take note of wire positions for easy connection in Step 7.

Repair

- Remove the din rail, filter, and rocker switch (snaps into place). Replace with new components. Secure din rail and filter to the rear control center assembly cover (1) using the four screws (40). Snap rocker/rotary switch into position.

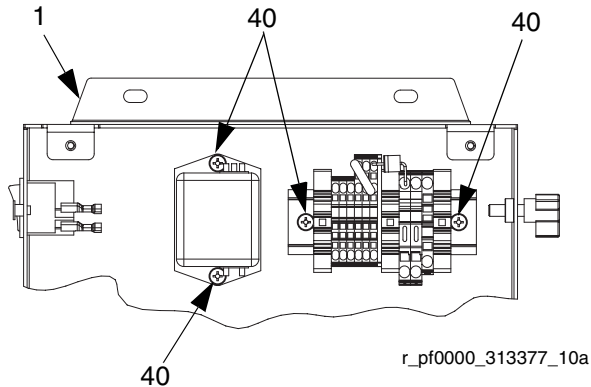

FIG. 66: 24 Vdc Din Rail Assembly

- Reconnect all wiring to the din rail module, filter, and rocker/rotary switch.
- Reassemble the line voltage assembly cover using the screws and washers.

Replace Fuses

Replace fuses on the din rail assembly.

- For 24 Vdc control centers: see **Technical Data** on page 140 for fuse specifications.
- For 100-240 Vac control centers: Order fuse 115805.

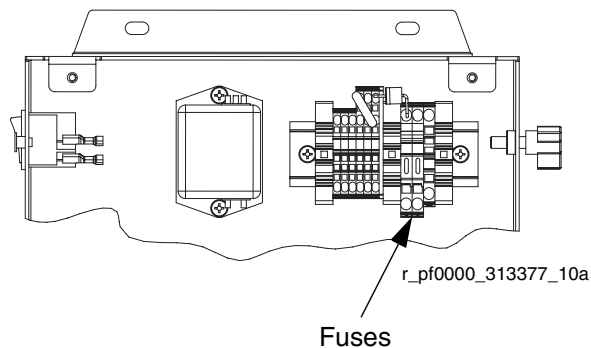

FIG. 67: Fuse Location

Parts

Control Centers

Software Upgrade Tokens

Part	Description
★ ✕ 16K743	Includes PCF software for the ADM, FCM, CGM, and DGM
★ * 16N601	PCF Gateway map token: Installs the CGM map starting on page 122.
★ 16K742	Historical PCF Gateway map token: Only for users that used the original PCF with a Gateway, have purchased a new PCF, and do not wish to change their Gateway setup from the old Gateway map to the new Gateway map.

Control Center Key Token Part Numbers

See **Key Tokens** on page 20 for more information about key tokens.

Part	Description
★16M217	ADM Key Token, Standard PCF

Gateway Module Part Numbers

PCF Model	User Interface Description	Gateway Part Number To Order
PFxx0x	Discrete	★24B681
PFxx1x	DeviceNet™	★15V759
PFxx2x	Ether-Net/IP™	★15V760
PFxx3x	PROFIBUS™	★15V761
PFxx4x	PROFINET™	★15V762

Control Center and Expansion Swirl Enclosure Parts

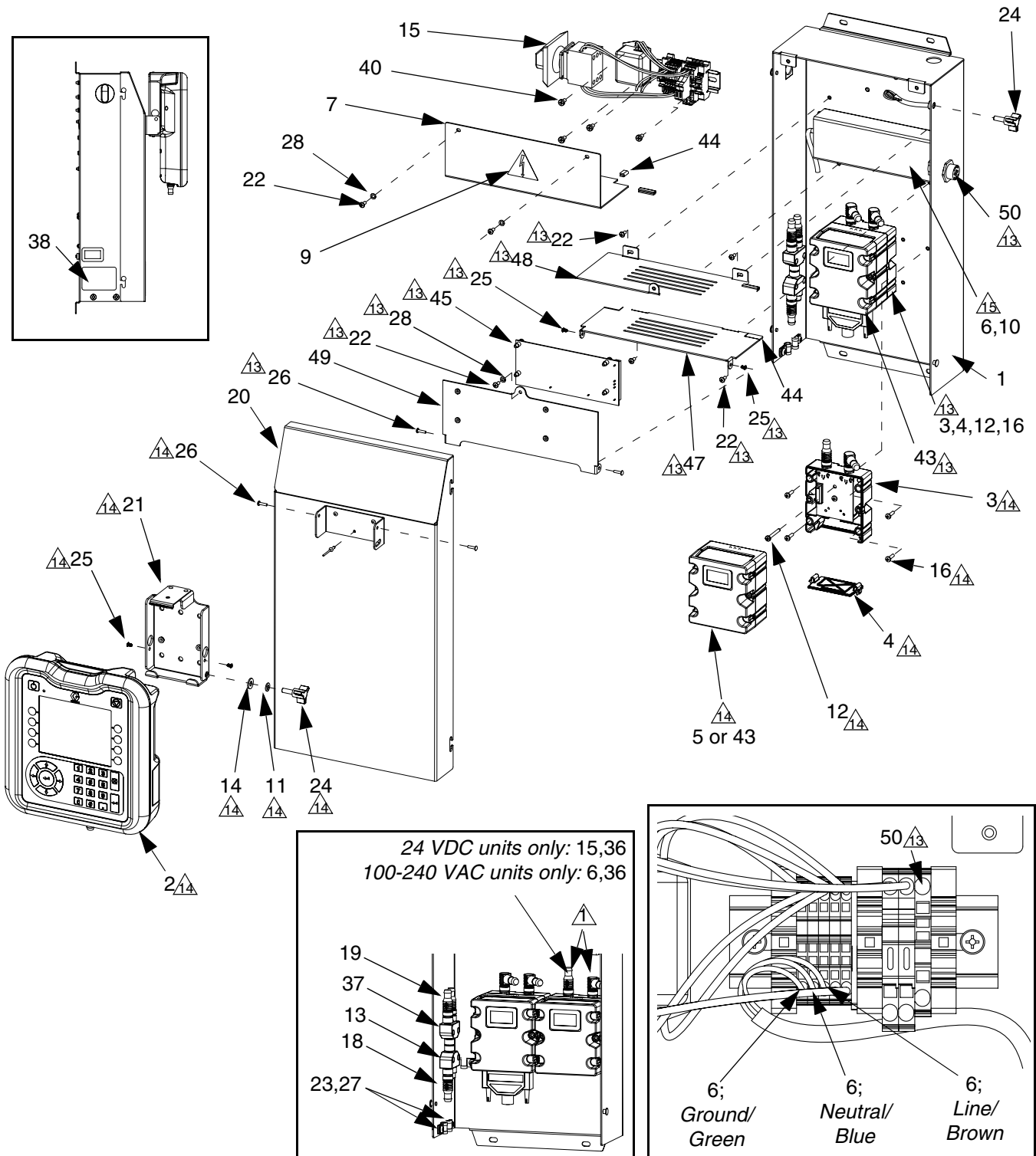

⚠ Add ferrite (36) to cable. Locate as close to cable connector as possible.

⚠ Control centers only. Not included in expansion swirl enclosures.

⚠ Included in swirl models only (both control centers and expansion swirl enclosures).

⚠ 100-240 Vac models only.

Control Center Assembly Parts

Ref.	Part	Description	Qty.	Ref.	Part	Description	Qty.
1	---	COVER, rear	1	43⊗	24B681	MODULE, DGM	1
2⊗	24E451	DISPLAY, with USB	1	44	---	GUARD, edging	1
3◆	289697	BASE, cube	1	45	16K570	BOARD, circuit, swirl	1
4◆	277674	ENCLOSURE, cube door	1	46	---	BRACKET, display pivot	1
5⊗	---	MODULE, Gateway; see table on page 91 for part number	1	47	---	COVER, swirl, hinge side	1
6‡	---	SUPPLY, power	1	48	---	COVER, swirl, latch side	1
7‡❖	---	COVER, line voltage	1	49	---	COVER, swirl, lid	1
8‡❖	---	GROMMET	1	50	24K455	CABLE, swirl board, panel mount	1
9▲‡	196548	LABEL, warning, electric shock	1	51	24K458	CABLE, SWIRL-DGM	1
10‡	---	SCREW, cap, socket hd; m4 x 6	4	52	121597	CABLE, CAN, 90 female/90 female	1
11❁	---	WASHER, lock	1	▲ Replacement Danger and Warning labels, tags, and cards are available at no cost.			
12◆	121820	SCREW, mach, pan hd; m4 x 35	1	‡ Parts included with 100-240 Vac Module kit 24B928.			
13	121807	CONNECTOR, splitter	1	❖ Parts included with 24 Vdc Module kit 24B929.			
14❁	110755	WASHER, plain	1	❁ Parts included with Display Mounting Bracket kit 24B930.			
15‡❖	---	MODULE, line voltage	1	⊗ Base electronic components do not have PCF-spe- cific software installed. Use software upgrade token (16K743) to install software before use.			
16◆	195875	SCREW, mach, pan hd	4	* Fieldbus Gateway modules do not have a PCF-spe- cific map installed. Use map token (16N601) to install map before use.			
18	121001	CABLE, CAN, female / female 1.0m	1	--- Not for sale.			
19	121000	CABLE, CAN, female / female 0.5m	1				
20	---	COVER, front	1				
21❁	---	BRACKET, mounting	1				
22‡❖	---	SCREW, mach, pan hd	2				
23	120143	GUIDE, strain relief	2				
24❁	121253	KNOB, display	2				
25❁	---	CLIP, speed, tubular	2				
26❁	---	RIVET, aluminum	1				
27	112925	SCREW, cap	2				
28	100020	WASHER, lock	2				
36	121901	SUPPRESSOR, box snap, ferrite	2				
37	124654	CONNECTOR, splitter	1				
38	---	LABEL	1				
40	---	SCREW, mach, pan hd	4				

Fluid Plate Assembly Parts

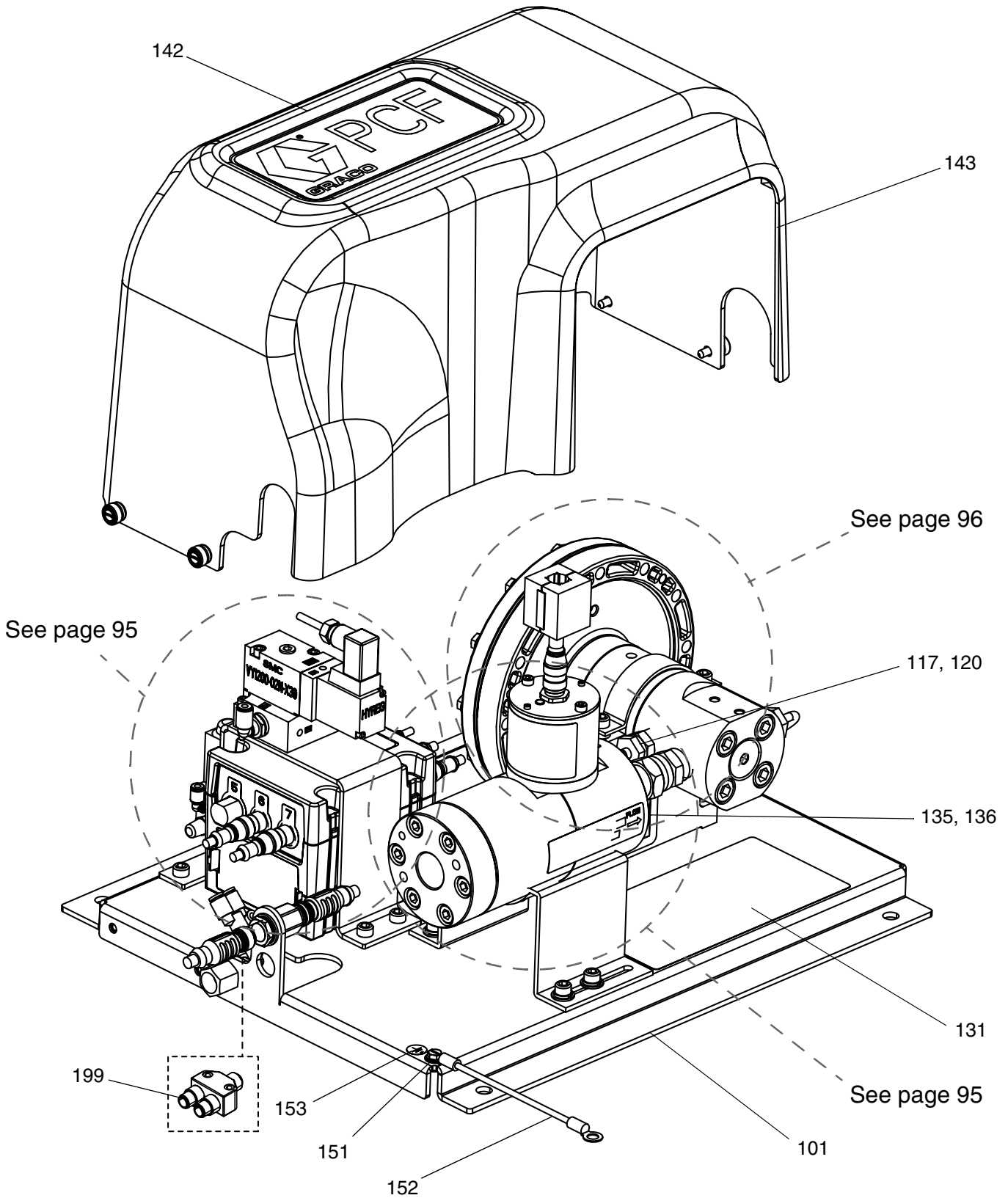

Fluid Plate Assembly Parts (continued)

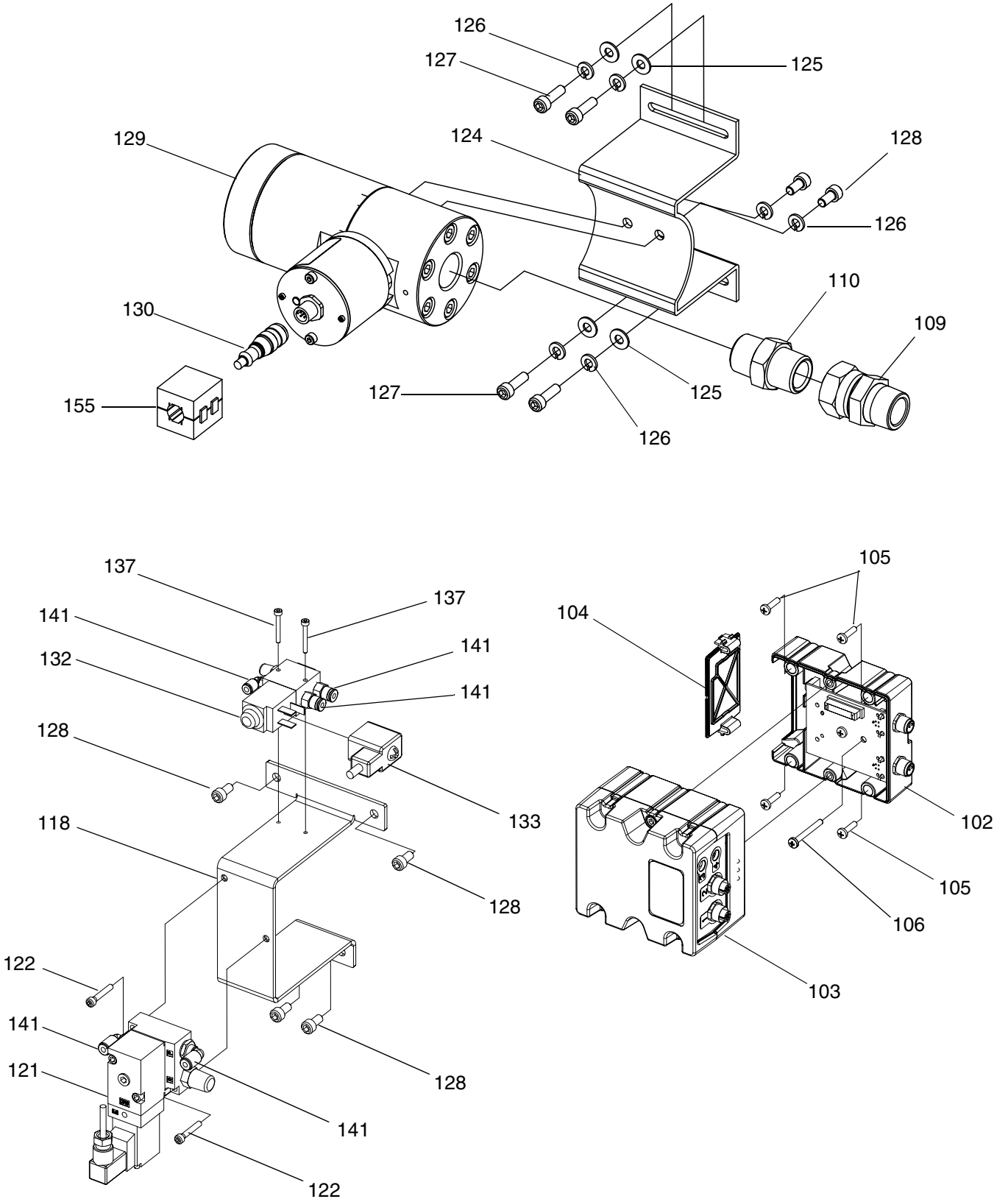

Fluid Plate Assembly Parts (continued)

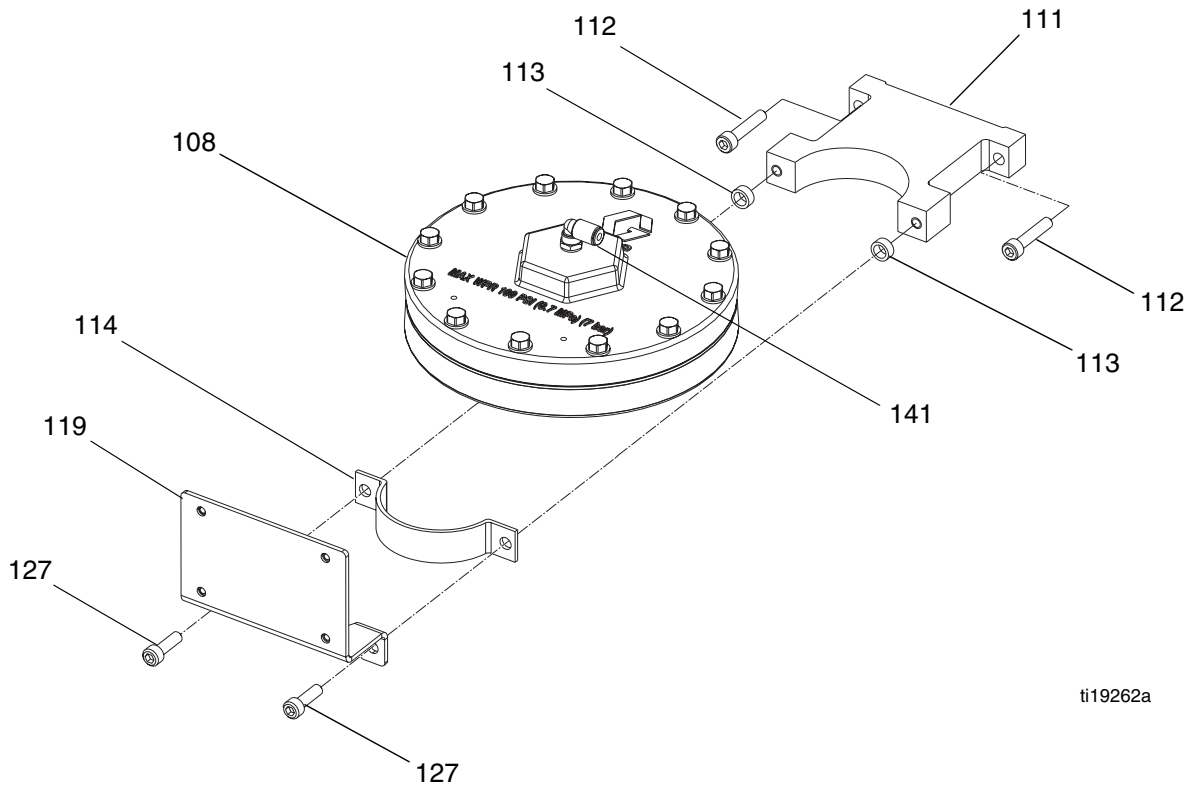

ti19262a

Fluid Plate 24B962 Shown

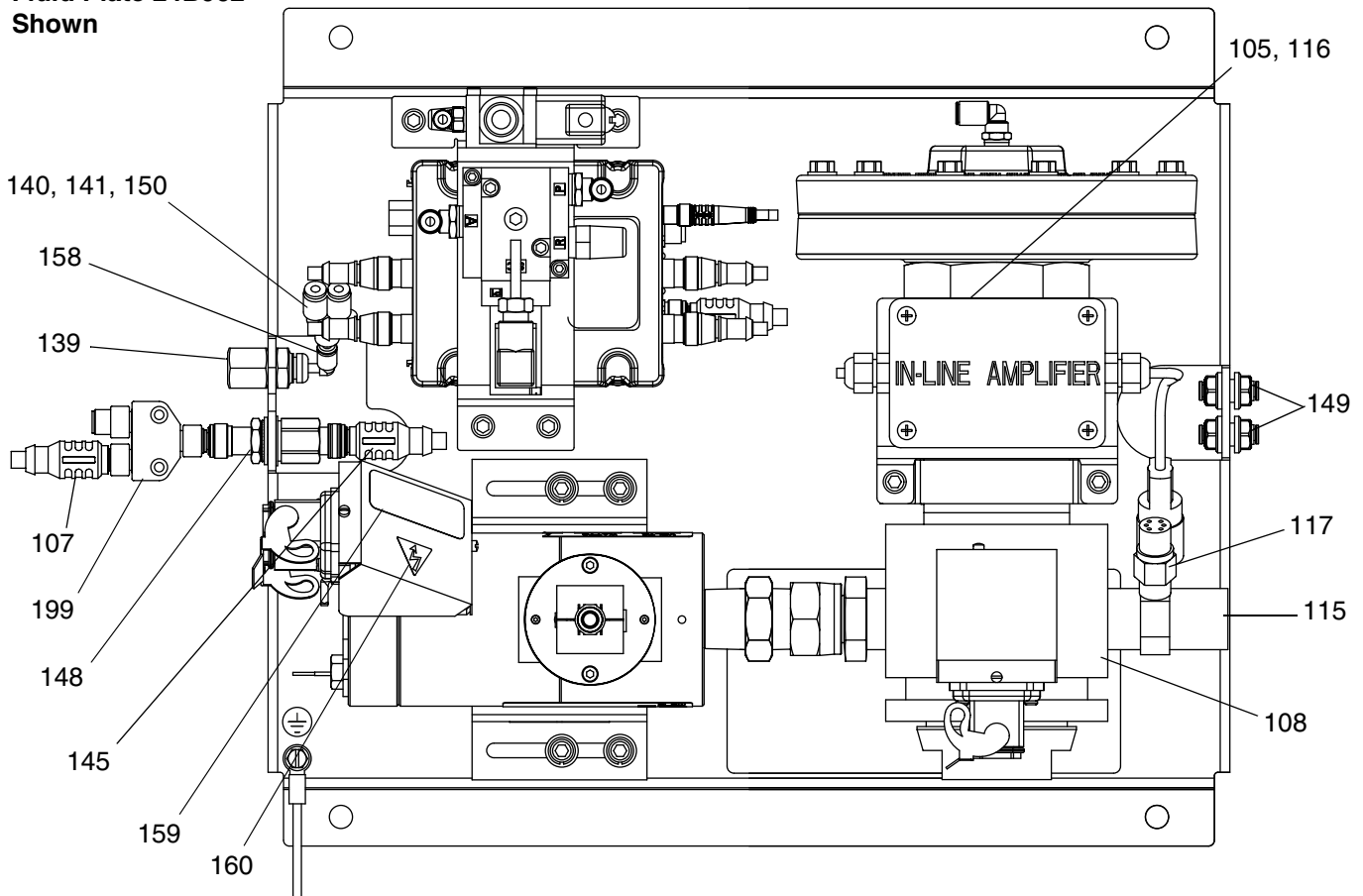

Fluid Plate Assembly Parts

Ref.	Part	Description	Qty.
101	---	PLATE, fluid	1
102	289697	BASE, cube	1
103✘	289696	FCM, cube	1
104	277674	ENCLOSURE, cube door	1
105✓	---	SCREW, mach, pan hd	1
106	121820	SCREW, machine, pan hd; m4 x 35	1
107	121228	CABLE, CAN, female/female; 15.0 m	1
108✓	---	REGULATOR, assy	1
109✓	---	UNION, adapter	1
110✓	---	NIPPLE, reducing, hex; 1/2 npt(f) x 3/4 npt(f)	1
111	198269	BRACKET, flow meter, lower	1
112	110580	SCREW, cap, socket hd	2
113✓	---	SPACER	1
114	198268	BRACKET, flow meter	1
115✘	624545	FITTING, tee; 3/4(m) x 1/4(f)	1
116✘	258530	AMPLIFIER, signal conditioner	1
117✓	---	SENSOR, pressure, fluid outlet	2
118	---	BRACKET, valve	1
119✘	16P819	BRACKET, signal conditioner	1
120✓	---	O-RING	1
121	120010	REGULATOR, I/P	1
122	111119	SCREW, valve	2
124✓	---	BRACKET, helical gear meter	1
125✓	---	WASHER, plain	1
126✓	---	WASHER, lock, spring; m6	1
127✓	---	SCREW, cap, socket hd	1
128✓	---	SCREW, cap, socket hd, hex	1
129✓	---	METER, assy	1
130✓	---	CABLE; m12-5p	1
131▲	15X756	LABEL, warning, main	1
132	258334	VALVE, dispense, fluid plate	1
133	121806	CABLE, solenoid	1
135▲✘	189285	LABEL, caution, hot surface	1
136	---	LABEL	1
137	117820	SCREW, cap, socket hd; m3	2
139	198179	FITTING, bulkhead, union	1
140	198175	FITTING, push	1
141	---	TUBE, nylon, round, black; 5.5	1
142	---	LABEL	1
143	---	SHROUD, fluid plate	1
145	121226	CABLE,CAN, male/female; 0.5 m	1
146★	234967	KIT, dual filter	1
147✓★	---	TOKEN, key	1
148	121612	CONNECTOR, thru; m12, m x f	1
149	121818	BULKHEAD, tube; 5/32	2
150	---	TAG, installation	1
151	114391	SCREW, grounding	1

Ref.	Part	Description	Qty.
152	194337	WIRE, grounding, door	1
153▲	186620	LABEL, ground	1
155✓	---	SUPPRESSOR, box snap, ferrite	1
158	122610	ELBOW	1
159▲	290228	LABEL, caution, hot surface	1
160▲	189930	LABEL, caution, electric shock	1
199*	124654	SPLITTER, CAN	1

▲ Replacement Danger and Warning labels, tags, and cards are available at no cost.

✓ See **Parts Varying by Assembly** table, page 98, for part number and quantity.

✘ Only included with fluid plates that use a heated mastic regulator.

✘ Base electronic components do not have PCF-specific software installed. Therefore, use software upgrade token (16K743) to install software before use.

★ Not shown.

--- Not for sale.

* CAN splitter is not included with the fluid plate assembly included in the PFxxxx assembly. It is included only with the additional fluid plate kits.

Fluid Plate Key Token Part Numbers

See **Key Tokens** on page 20 for more information about key tokens.

Part	Description
★16M100	FCM Key Token, 2 styles, Flow Meter
★16M101	FCM Key Token, 2 styles, No Flow Meter
★16M102	FCM Key Token, 16 styles, Flow Meter
★16M103	FCM Key Token, 16 styles, No Flow Meter
★16M104	FCM Key Token, 256 styles, Flow Meter
★16M105	FCM Key Token, 256 styles, No Flow Meter

Parts Varying by Assembly

The following table lists the varying part numbers by fluid plate assembly, and the quantity for each assembly.

Ref.	Part	Description	Fluid Plate Assemblies					
			Cartridge Regulator with High Resolution Meter	Cartridge Regulator with No Meter	Mastic Regulator with High Resolution Meter	Mastic Regulator with No Meter	Heated Mastic Regulator with Heated High Resolution Meter	Heated Mastic Regulator with No Meter
105	195875	SCREW, mach, pan hd	4	4	4	4	8	8
108	244734	REGULATOR, assy	1	1				
	246642				1	1		
	246643						1	1
109	156684	UNION, adapter	1	1				
	157785						1	
110	C20461	NIPPLE, reducing,	1					
	C20487	hex; 1/2 npt(f) x 3/4 npt(f)			1		1	
113	C34045	SPACER	2	2				
117	15M669	SENSOR, pressure,	2	2	2	2		
	117764	fluid outlet					1	1
120	111457	O-RING	2	2	2	2		
124	117670	BRACKET, helical gear meter	1		1		1	
125	C19197	WASHER, plain	4		4		4	
126	---	WASHER, lock, spring; m6	6		6		6	
127	108328	SCREW, cap, socket hd	6	2	6	2	6	2
128	107530	SCREW, cap, socket hd, hex	6	4	6	4	6	4
129	246652	METER, assy.	1		1			
	246340						1	
130	122030	CABLE; m12-5p	1		1		1	
147★	16M100	TOKEN, key, 2 styles, meter enabled	1		1		1	
	16M101	TOKEN, key, 2 styles, meter disabled		1		1		1
	16M102	TOKEN, key, 16 styles, meter enabled	1		1		1	
	16M103	TOKEN, key, 16 styles, meter disabled		1		1		1
	16M104	TOKEN, key, 256 styles, meter enabled	1		1		1	
	16M105	TOKEN, key, 256 styles, meter disabled		1		1		1
155	121901	SUPPRESSOR, box snap, ferrite	1		1		1	

--- Not for sale.

Appendix A - Advanced Display Module (ADM)

Display Overview

The ADM display is divided into two main functions: Setup Mode and Run Mode.

Setup Mode Functions

The setup mode functions enable users to:

- configure installed system components
- set units, adjust values, set formats, and view software information for each component
- set or change information regarding the Gateway module
- view information regarding the particular Gateway module used
- set controls and valve commands
- set on and off delays for valves and the regulator
- set k-factor, pressure, and flow rate variables
- set offsets for inlet and outlet pressures
- set error types
- set variables for maintenance advisories
- set up to 256 styles for models with a CGM and set up to 16 styles for models with a DGM

Run Mode Functions

The run mode functions enable users to:

- adjust the bead scale
- perform manual dispensing
- view a chronological list of system errors
- view a chronological list of jobs stored/performed in the system
- use a preventative maintenance schedule for the supply system, displacement pump, and air motor

Display Details

Power Up Screen

The following screen appears when the ADM is powered up. It remains on while the ADM runs through initialization and establishes communication with other modules in the system.



Menu Bar

The menu bar appears at the top of each screen.



Date and Time

The date and time are always displayed in one of the following formats. The time is always displayed as a 24-hour clock.

- DD/MM/YY HH:MM
- MM/DD/YY HH:MM
- YY/MM/DD HH:MM

Arrows

The left and right arrows indicate screen navigation.

Screen Menu



The screen menu indicates the currently active screen, which is highlighted. It also indicates the associated screens that are available by scrolling left and right.

System Mode

There are five modes: Active, Job in Cycle, Display Control, Swirl Setup, and System Off. The current system mode is displayed at the left of the menu bar.

Alarm/Deviation

If there is an active system error, one of the following icons is displayed in the middle of the menu bar. There are four possibilities:

Icon	Function	Description
No Icon	No information or no error has occurred	---
	Advisory	Informational
	Deviation	Important but will not shut down the affected fluid plate
	Alarm	Very important and will immediately shut down the affected fluid plate

Status

The current system status is displayed at the right of the menu bar.



Soft Keys

Icons next to the soft keys indicate which mode or action is associated with each soft key. Soft keys that do not have an icon next to them are not active in the current screen.



NOTICE



To prevent damage to the soft key buttons, do not press the buttons with sharp objects such as pens, plastic cards, or fingernails.





Jump In/Jump Out

In screens that have editable fields, press  to access the fields and make changes. When changes are complete press  again to exit edit mode.

Navigation within Screens



Press  to open drop-down menus on Setup screens. Also, press  to enter changes or make a selection.

Press   to navigate to new screens and to navigate left and right within a screen.

Press   to navigate to new screens and to navigate up and down within a screen. Also press   to move between fields within a drop-down menu, and to increment or decrement numbers within a field.





Setup Mode

Setup mode screens are divided into five sections: System setup, Advanced setup, Gateway setup, Fluid Plate setup, and Swirl setup. While in Run mode, press 

to enter Setup mode. Press   to navigate through the Setup mode screens.

If the setup screens are password protected, a password entry screen will appear after pressing . The password is defined in the Advanced setup screen. If the password is set to 0000, the password is disabled.

Advanced Setup Screens

There are four Advanced setup screens, which enable users to set units, adjust values, set formats, define USB settings, and view software information for each component. Press   to scroll through the Advanced setup screens. Once in the desired Advanced setup screen, press  to access the fields to make changes. Press  to exit edit mode.

NOTE: Users must be out of edit mode to scroll through the Advanced setup screens.

Advanced Setup Screen 1

This screen enables users to set the language, date format, current date and time, password, and number of minutes before the screen saver comes on. The time does not automatically update for daylight savings time.

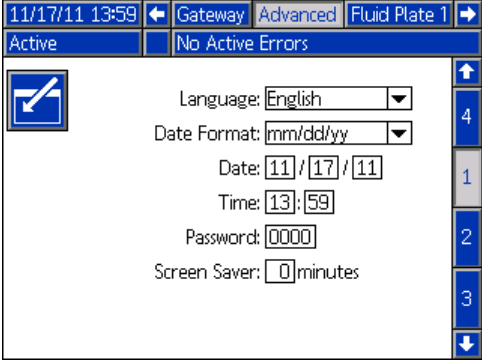

Advanced Setup Screen 2

This screen enables users to set the units of measure for maintenance volume, maintenance mass, pressure, and flow rate.

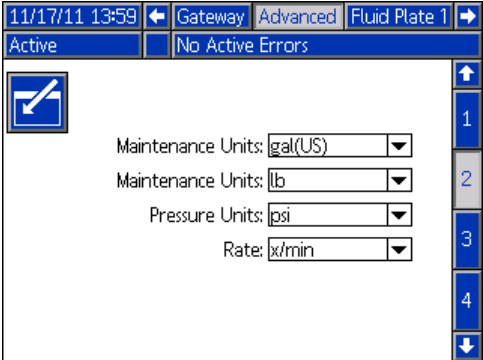

Advanced Setup Screen 3

This screen enables users to setup USB-related settings. The Disable USB Log Errors option disables recording events when the logs are at least 90% full.

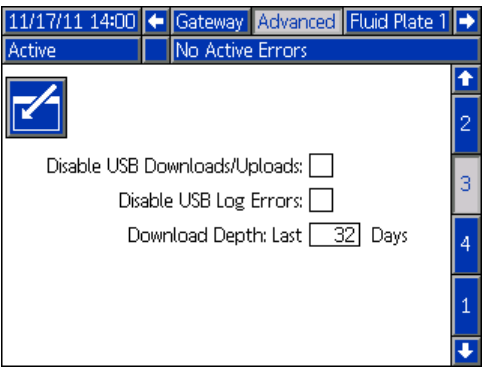

Advanced Setup Screen 4



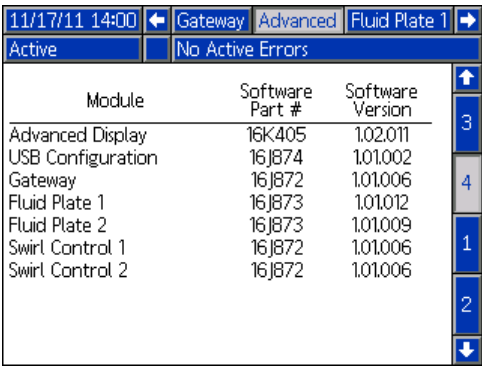

This screen displays the software part number and version for the ADM, USB configuration, Gateway module, and fluid plates.



Module	Software Part #	Software Version
Advanced Display	16K405	1.02.011
USB Configuration	16J874	1.01.002
Gateway	16J872	1.01.006
Fluid Plate 1	16J873	1.01.012
Fluid Plate 2	16J873	1.01.009
Swirl Control 1	16J872	1.01.006
Swirl Control 2	16J872	1.01.006

Automation Gateway Setup Screens

There are up to three automation Gateway Setup screens (depending on fieldbus), which enable users to set or change information regarding the automation Gateway module used on the PCF system. These screens also enable users to view information regarding the particular automation Gateway module used.

Press   to scroll through the Gateway Setup screens. Once in the desired Advanced Setup screen, press  to access the fields to make changes. Press  to exit edit mode.

NOTE: Users must be out of edit mode to scroll through the Gateway Setup screens.

Gateway Setup Screen 1 - DeviceNet

This screen enables users to set the device address and the baud rate. The DeviceNet screen displays the hardware revision number, system serial number, map ID, name, revision number, and install date.

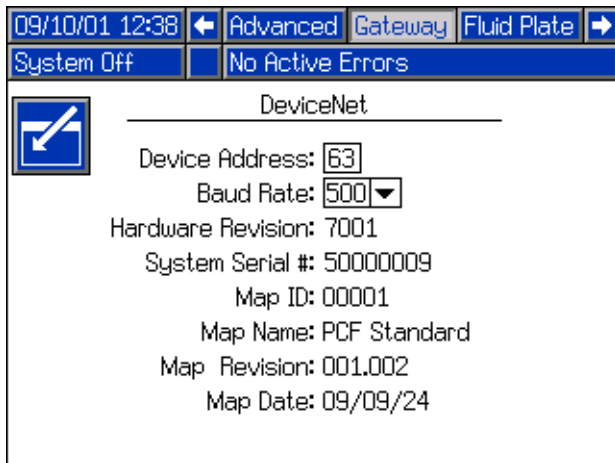

Gateway Setup Screen 1 - EtherNet/IP

This screen enables users to set the IP address, subnet mask, Gateway, DNS 1, DNS 2, and if a DHCP is used.

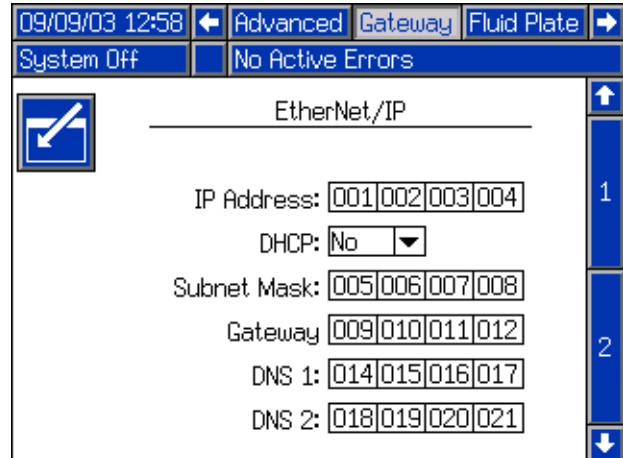

Gateway Setup Screen 2 - EtherNet/IP

This screen is the same for EtherNet/IP and PROFIBUS. It enables users to view the following information regarding the Gateway module used on the PCF system:

- hardware revision number
- system serial number
- map ID number
- map name
- map revision number
- date the map was created

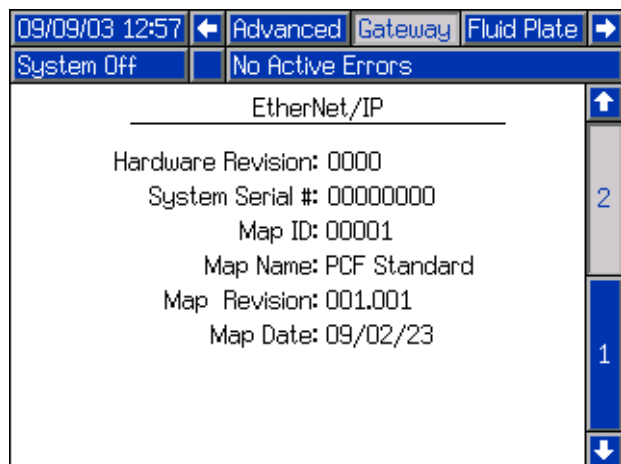

Gateway Setup Screen 1 - PROFIBUS

This screen enables users to set the device address, install date, location tag, function tag, and system description.

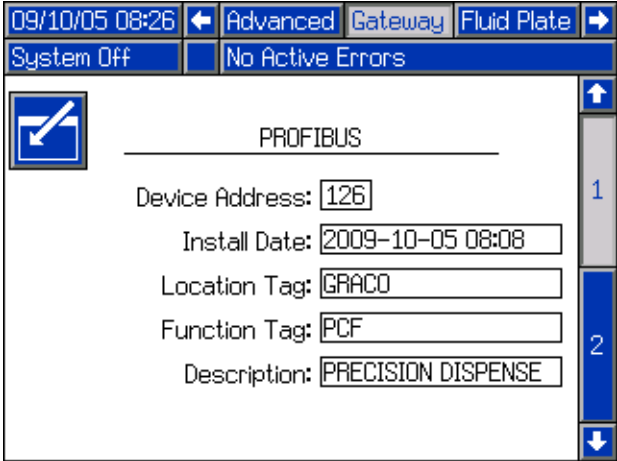

Gateway Setup Screen 2 - PROFINET

This screen enables users to set the device address, install date, location tag, function tag, and system description.

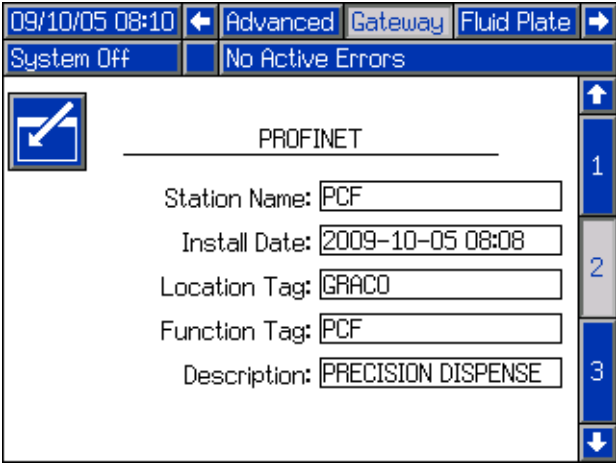

Gateway Setup Screen 2 - PROFIBUS

This screen is the same for EtherNet/IP and PROFIBUS. See Gateway Setup Screen 2 - EtherNet/IP, page 102, for details.

Gateway Setup Screen 3 - PROFINET

This screen enables users to view the following information regarding the Gateway module used on the PCF system:

Gateway Setup Screen 1 - PROFINET

This screen enables users to set the IP address, subnet mask, Gateway, DNS 1, DNS 2, and if a DHCP is used.

- hardware revision number
- system serial number
- map ID number
- map name
- map revision number
- date the map was created

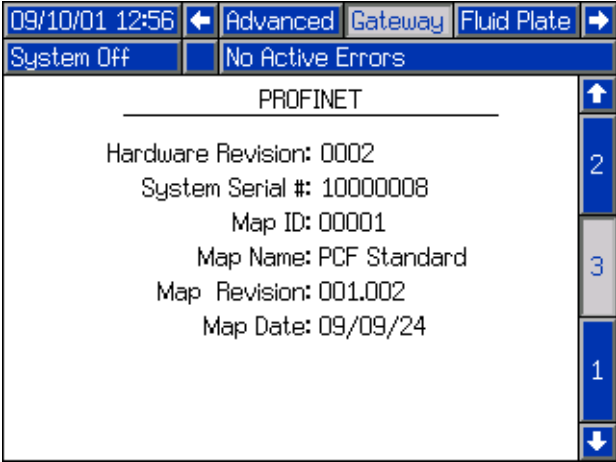
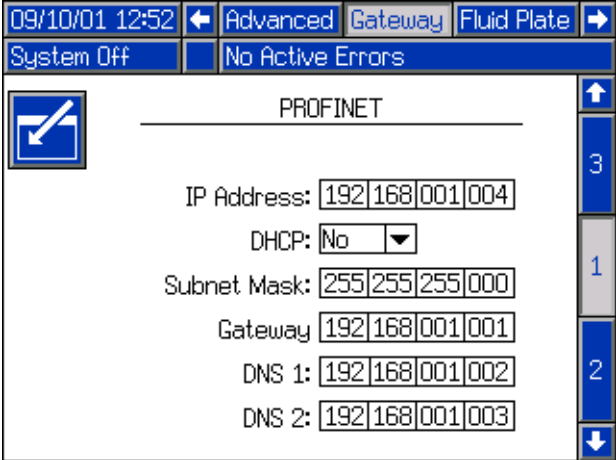

Discrete Gateway (Automation) Setup Screen

NOTE: The Discrete Gateway Setup screen is not available if an automation Discrete Gateway Module (DGM) is not attached to the system.

NOTE: If Swirl Dispensers are installed, a Swirl Discrete Gateway Module will be installed. This section is not related to that module. See **Control Center Assembly Overview** on page 16 for gateway identification.

This screen enables users to set Active Errors to High (default) or Low. If High is selected, alarm and error signals are low during normal operation and high if an alarm or error exists. If Low is selected, alarm and error signals are high under normal operation and low if an alarm or error exists.

This screen also enables users to select the Command Value Type signal (Analog or Digital) the automation system will provide to PCF. If Analog control is selected, the user must provide an analog voltage to the proper input on the DGM. See **Appendix B - Discrete Gateway Module (DGM) Connection Details**, page 115, for connection details.

If Digital control is selected and one fluid plate is installed, the user can define three digital settings for each dispense valve. If Digital control is selected and two fluid plates are installed, the user can define two digital settings for each dispense valve. The user must provide two digital signals to the proper inputs on the DGM. See **Appendix B - Discrete Gateway Module (DGM) Connection Details**, page 115, and the **Digital Command Logic Table** for connection details.

NOTE: The control mode for each dispense valve is set in the **Fluid Plate x, Screen 2 (Mode Settings)**, page 105. For example, if Valve 1 is set to Pressure mode on the **Fluid Plate x, Screen 2 (Mode Settings)**, then the digital commands for Valve 1 are pressure values.



The Digital Command Logic Table indicates which value each input must be set to in order to select a particular setting.

Digital Command Logic Table (Single Fluid Plate Systems)

Digital Command Input 1	Digital Command Input 2	Resulting Digital Command Selection
Low	Low	Setting #1
High	Low	Setting #2
---	High	Setting #3

Digital Command Logic Table (2-Fluid Plate Systems)

Digital Command Input 1	Digital Command Input 2	Resulting Digital Command Selection
Low	---	Fluid Plate 1, Setting #1
High	---	Fluid Plate 1, Setting #2
---	Low	Fluid Plate 2, Setting #1
---	High	Fluid Plate 2, Setting #2

Press  to access the fields to make changes. Press  to exit edit mode.





Single fluid plate system

2-fluid plate system

Fluid Plate Setup Screens

There are nine fluid plate setup screens, which enable users to:

- Set controls and valve commands
- Set on and off delays for valves and the regulator
- Set k-factor, pressure, and flow rate variables
- Set offsets for inlet and outlet pressures
- Set error types
- Set variables for maintenance advisories
- Define styles
- Associate swirl dispenser with fluid plate

Press   to scroll through the fluid plate setup screens. Once in the desired screen, press  to access the fields to make changes. Press  to exit edit mode.

NOTE: Users must be out of edit mode to scroll through the fluid plate setup screens.

Fluid Plate x, Screen 1 (Control Settings)

This screen enables users to:

- Set the dispense trigger source to Gateway, Command Cable, Command Cable 3x, or Combined. If it is set to Command Cable, users can enable the valves.
- Set the command value source to Gateway, Command Cable, or Display.
- Set the Job End Timer to Timer or Gateway. If this field is set to Timer, users can set Job End Delay.
- Set the Display Control Password to Enable or Disable. When entering maintenance mode, a password prompt will appear if the Display Control Password is set to Enable and a password is set in the Advanced setup screens.

- Set the Run Mode Bead Adjust to Enable or Disable.

NOTE: Run mode bead adjust allows a user to quickly adjust flow rate or pressure from the run screen.

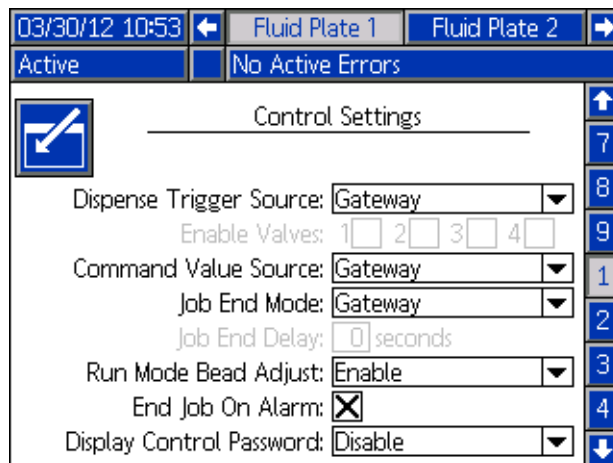

Fluid Plate x, Screen 2 (Mode Settings)

This screen enables users to set valve commands. Use this screen to select a mode (pressure, bead, shot, or full open) for each valve. Users can also set the flow rate or pressure for each valve, and adjust the bead scale.

NOTE: The ability to dispense from multiple valves simultaneously is only allowed in either of the following scenarios.

- Each valve is set to Pressure mode and has identical command values.
- Each valve is set to Full Open mode.

Attempting to dispense from multiple valves simultaneously using any other combination will cause an Incompatible Valves Settings alarm.

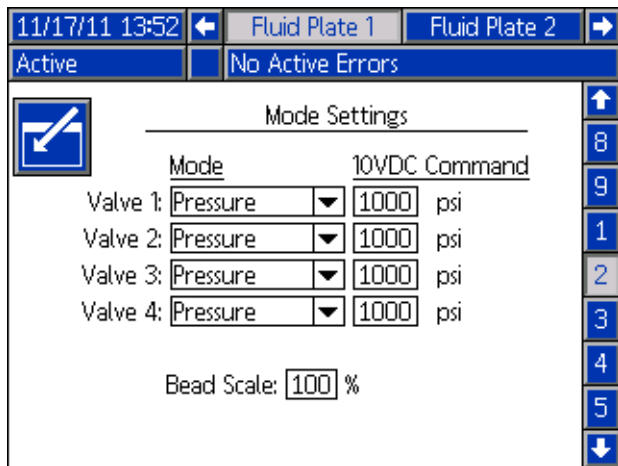

Fluid Plate x, Screen 3 (Delay Settings)

This screen enables users to set on and off delays (in milliseconds) for each valve and the regulator. For an explanation of the on and off delays, refer to the **On/Off Delays** section on page 39.

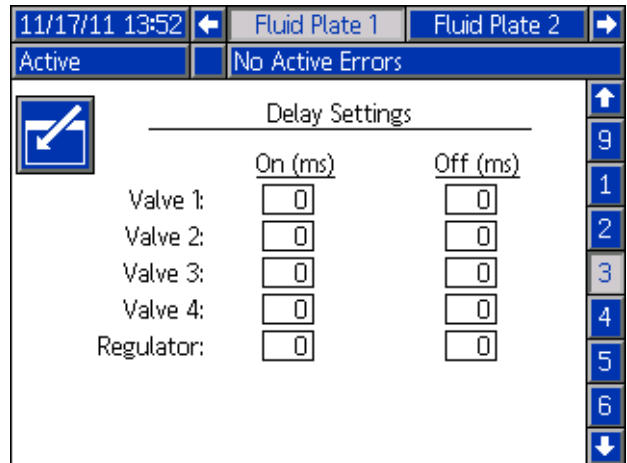

Fluid Plate x, Screen 4 (Control Loop and Flowmeter Settings)

This screen enables users to set the meter type (volume or mass) and the K-Factor for the flowmeter. Users can also set the Kp, Ki, and Kd for the pressure control loop as well as Kp and Ki for bead control loop.

NOTE: In systems without a flow meter, the flow meter settings will be grayed out.

NOTE: It is recommended that these values not be changed from the factory defaults of 32.00 for Kp, 128.00 for Ki, and 0.00 for Kd.

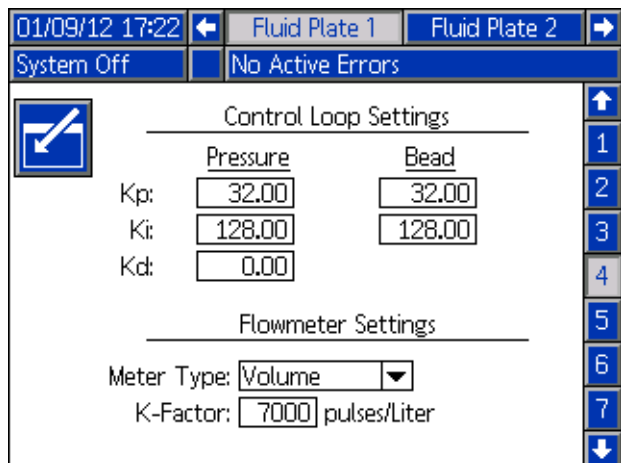

Fluid Plate x, Screen 5 (Pressure Sensors)

NOTE: Inlet sensor settings will be grayed out on this screen for systems with heated fluid plates.

This screen enables users to:

- Set the offset for the inlet and outlet pressures.
NOTE: The offset value must be set to a non-zero value before '-' can be selected from the +/- drop-down menu.
- Set the minimum and maximum pressure limits for the inlet, and the maximum pressure limit for the outlet.
- Set the error type (alarm or deviation) that will be issued if the inlet and/or outlet pressure go outside of the set limits.

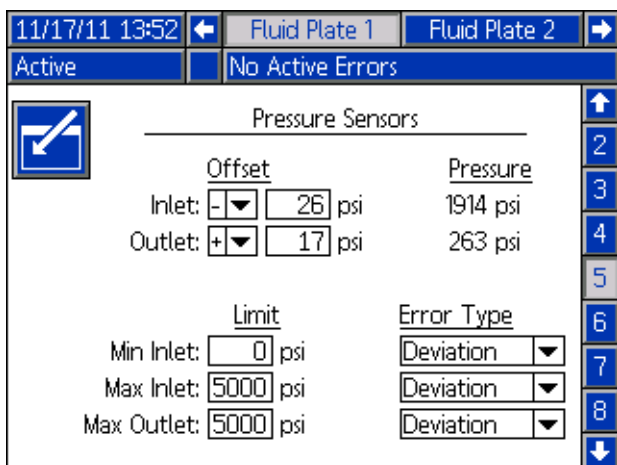

Fluid Plate x, Screen 6 (Error Type)

This screen enables users to set the error type (none, alarm, or deviation) that will be issued if the pressure, flow rate, volume, or computed target goes outside the tolerance settings of the active style. See **Configure Errors** on page 36.

NOTE: Only the low/high pressure errors will be enabled for systems without a flow meter.

- The pressure and flow rate errors are relative to the value commanded (through the command cable, gateway or display)
- The volume is relative to the requested volume and computed target errors are relative to the target volume defined in the style

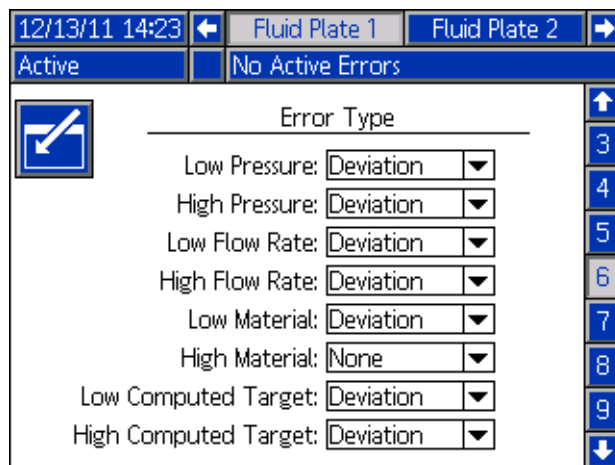

Fluid Plate x, Screen 7 (Maintenance Advisory Limits)

This screen enables users to set volume (or hours) limit that will trigger a maintenance advisory for the air supply, voltage to pressure (V/P) transducer, fluid regulator, flow meter, and all four valves.

NOTE: Hours is shown instead of Volume for fluid plates without a flow meter.

The Volume (or Hours) column displays the current totalizer value. If this value exceeds the set limit, the value will turn red and a maintenance advisory is issued. See **Fluid Plate x, Screen 3 (Maintenance Totalizers)**, page 113, for more information about maintenance totalizers.

	Limit	Volume
Supply:	0	79.251 gal(US)
V/P:	0	26.416 gal(US)
Regulator:	0	0.132 gal(US)
Flowmeter:	0	0.475 gal(US)
Valve 1:	0	17.313 gal(US)
Valve 2:	0	7.473 gal(US)
Valve 3:	0	0.006 gal(US)
Valve 4:	0	0.001 gal(US)

Fluid Plate x, Screen 8 (Style)

This screen enables users to set up to 256 styles, depending on system configuration. Press  to access the style setup fields. Enter the style number in the Style field, the target volume in the Volume field, and the tolerance percentage in the Tolerance field.

NOTE: The number of possible styles is dependent on the model type.

To enter the style name, press  while in the Style Name field. See **Keyboard Screen**, page 109, for instructions on using the keyboard screen to enter the style name.

01/10/12 13:37 Fluid Plate 1 Fluid Plate 2

System Off No Active Errors

 Style

Style: 1

Style Name:

Volume: 0.0 cc

Tolerances: -0% +0%

Pre-Charge

Mode: Display

Pressure: 0 psi

Fluid Plate x, Screen 9 (Swirl Association)

This screen enables users to set the swirl to fluid plate association. This allows the system to apply errors to the correct fluid plate when a swirl error occurs, and to stop the correct fluid plate from dispensing when certain swirl errors occur.

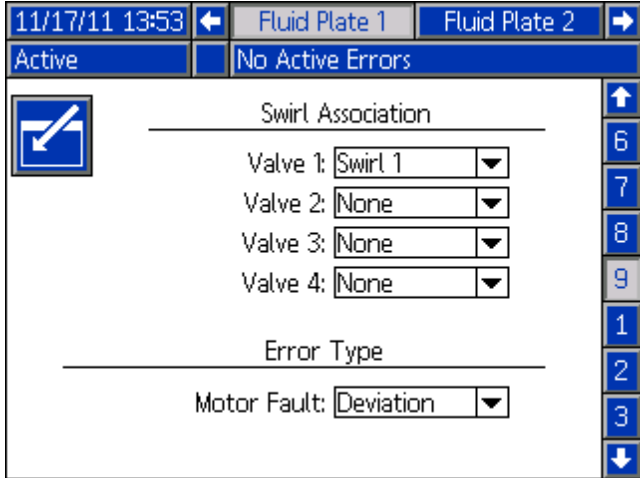

Keyboard Screen

The keyboard screen appears when text is edited. Use all four arrow buttons to select each letter; press to enter the letter. To back space, press . To delete the entire style name entered, press . To enter the style name, press . To cancel the entry and exit the keyboard screen, press .

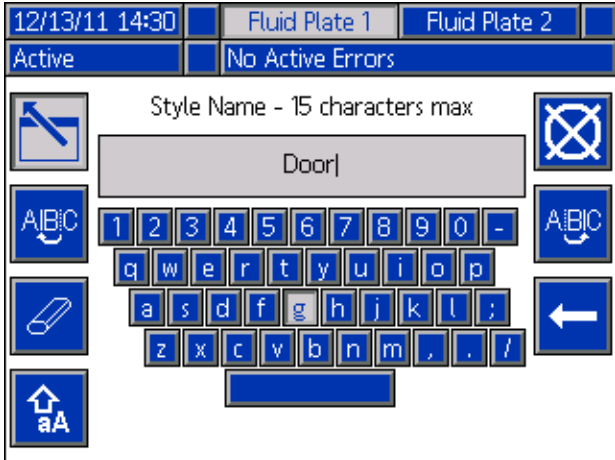

Swirl Setup Screen

This screen enables users to:

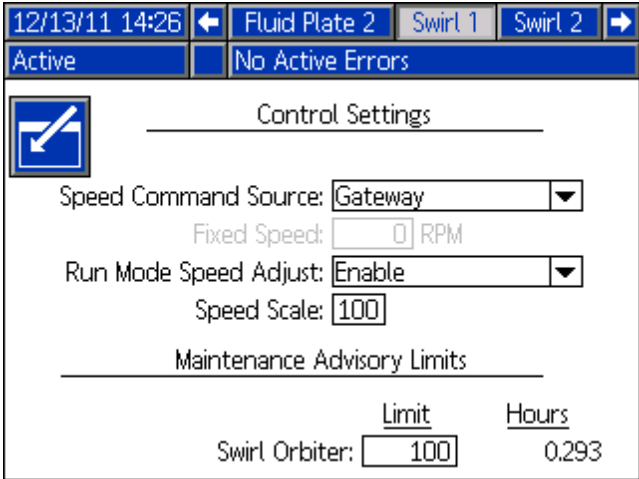

- Set the Speed Command Source to Display or Gateway. If it is set to Display, users can set the fixed speed
- Set the Run Mode Speed Adjust to Enable or Disable
- Set the speed scale from 50-150%
- Set the Swirl Orbiter Maintenance Advisory Limit



Run Mode

Run mode screens are divided into six sections: home, fluid plates, swirls, events, errors, and jobs. While in

Setup mode press  to enter Run mode. Press

  to navigate through the Run mode screens.

Fluid Plate Home Screen

NOTE: This screen only appears if more than one fluid plate is installed.

The Fluid Plate Home screen shows an overview for each of the individual fluid plates. The screen displays the following items:

- Open dispense valves
- Active style number and name
- Flow rate
- Inlet and outlet pressures
- Progress bar indicating actual amount dispensed (blue shaded portion), requested volume (upper and lower arrows) and target volume (end of white bar).

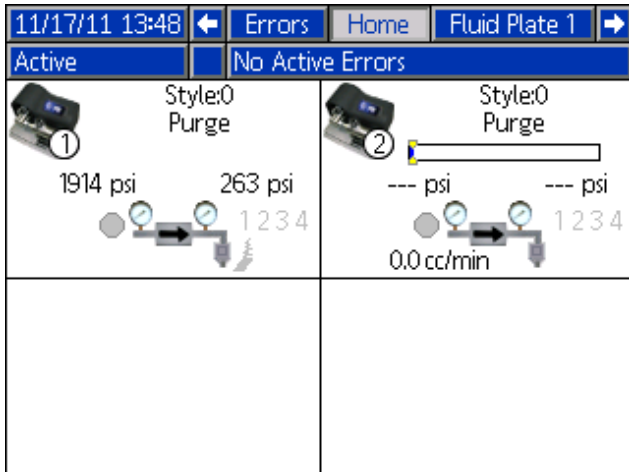

Swirl Home Screen

NOTE: This screen only appears if more than one Swirl Dispenser is installed.

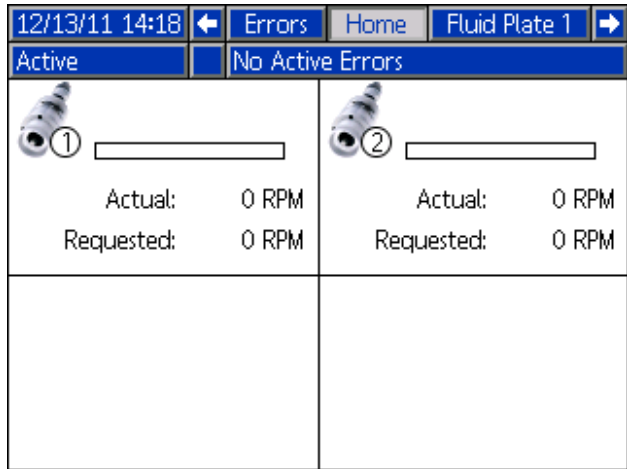

To access the Swirl Home screen, press the down arrow key from the Fluid Plate Home screen. The Swirl Home screen shows an overview for each of the individual Swirl Dispensers. The screen displays the following items:

- Requested motor speed
- Actual motor speed
- Progress bar indicating requested and actual motor speed



Fluid Plate x, Screen 1

This screen displays the current dispense control mode used, the current pressure, and the current style being dispensed. It also displays the target dispense volume, the actual dispense volume, and the requested dispense volume.

From this screen users can adjust the bead scale and enter maintenance mode. Press  and  to change the bead scale. Press  to enter maintenance mode.

The PCF system has two operating modes:

- **Dispense mode** – enables the module to begin dispensing when it receives a command from the automation unit.
- **Maintenance mode** – enables the module to begin dispensing when the user presses the manual dispense button. Dispense parameters and duration depend on the selected control.

Dispensing continues for as long as the manual dispense button  is pressed.

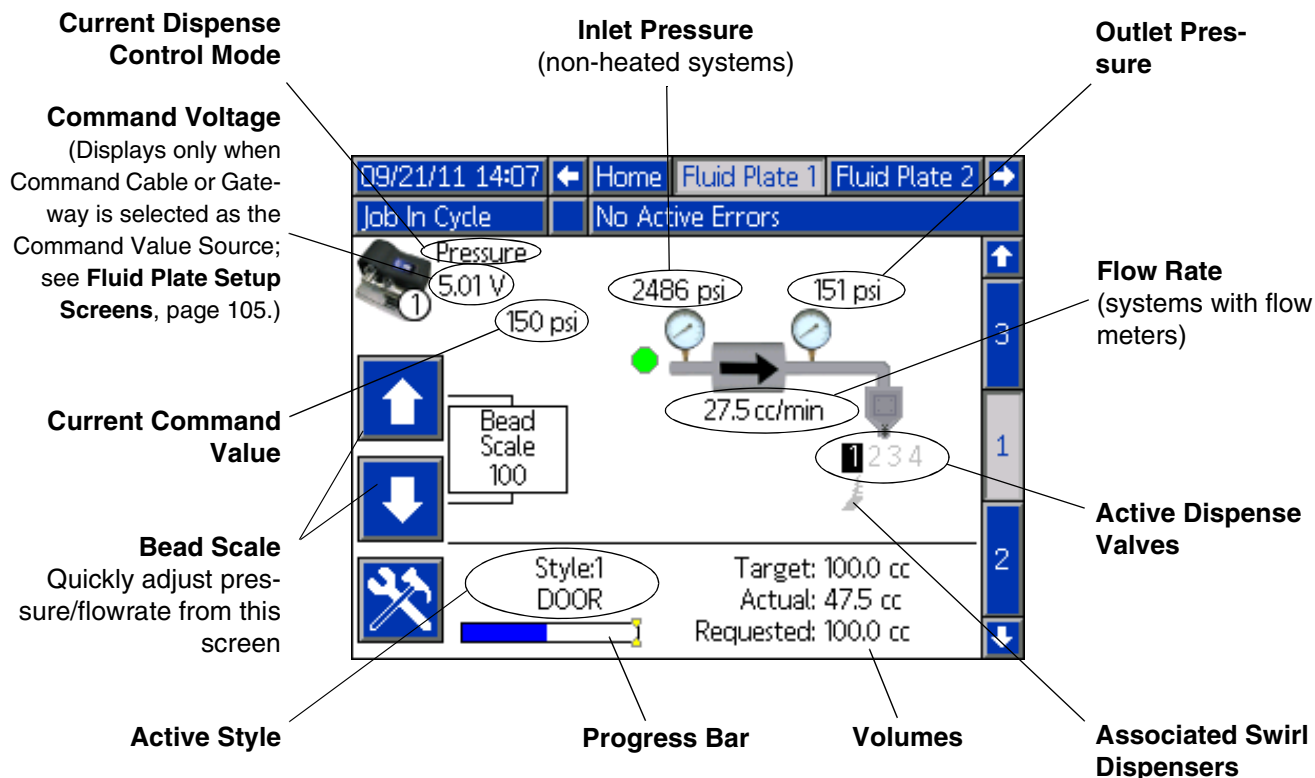

Maintenance Mode

Press  from Fluid Plate x, screen 1 (Control Center) to enter maintenance mode. Maintenance mode enables users to change the control mode, volume to be dispensed, target pressure, and number of dispense valves used in the system.

NOTE: Volume, pressure, and dispense valve options change according to mode.

See **Maintenance Mode Operation**, page 41, for instructions on changing the control mode, target pressure, and number of dispense valves used.

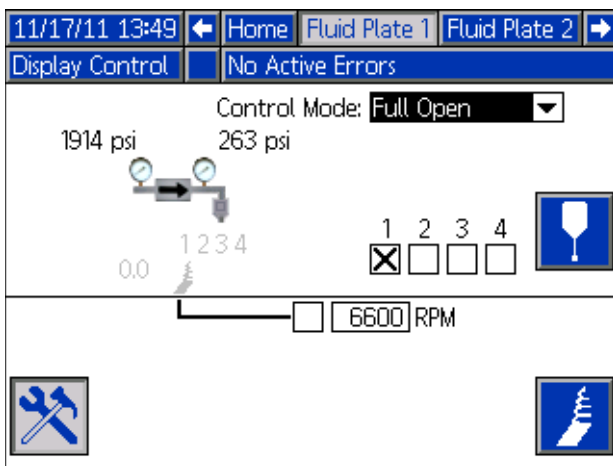

Dispense Control Modes

The PCF system has four fluid dispensing control modes.

- **Bead Control** – the system controls the flow rate of the material being dispensed. The regulator outlet pressure is varied to control the fluid flow rate to the requested value. Use the bead control when a consistent bead size is required.
- **Shot Control** – the regulator outlet pressure is controlled to the requested value. The dispense valve is closed when the target volume is reached or when the automation controller provides a signal.
- **Pressure Control** – the regulator outlet pressure is controlled to the requested value.
- **Full Open Control** – the PCF system does not control fluid pressure or flow. Instead the regulator opens to allow for recirculation applications.

Fluid Plate x, Screen 2 (Control Center)

NOTE: Users must be out of maintenance mode in Fluid Plate x, screen 1 in order to scroll to this screen.

NOTE: The term “Robot” on this screen refers to the automation controller.

This screen enables users to view and monitor the current status of the “robot” outputs and inputs. An X is displayed in the applicable check box when:

- Using a style strobe
- The dispense is complete
- A dispense trigger occurs
- The dispenser (fluid plate) is ready
- The dispense is in process
- There are no alarms or errors
- The dispense volume is correct

This screen also displays the current dispense style, command voltage, Gateway error number/code, and the volume dispensed.

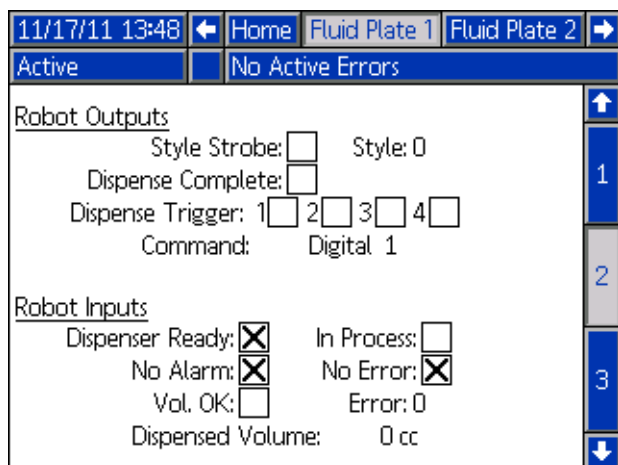

Fluid Plate x, Screen 3 (Maintenance Totalizers)

This screen enables users to view the maintenance totalizers for each system component and the limits set that will trigger a maintenance advisory.

Maintenance totalizers keep track of the total volume (or hours) that each system component has been running. If the totalizer value exceeds the set limit, the totalizer value will turn red and a maintenance advisory is issued.

The limits are set in the **Fluid Plate x, Screen 7 (Maintenance Advisory Limits)**, page 108, for the air supply, voltage to pressure (V/P) transducer, fluid regulator, flow meter, and all four valves.

NOTE: If a flow meter is not included in the system, this screen shows hours instead of volume and the flow meter entry is grayed out.

The screenshot shows the 'Maintenance Totalizers' screen for Fluid Plate 1. At the top, it displays the date and time '01/09/12 17:18' and navigation buttons for 'Home', 'Fluid Plate 1', and 'Fluid Plate 2'. Below this, a status bar indicates 'System Off' and 'No Active Errors'. The main content is a table with three columns: 'Volume' and 'Limit'. The 'Volume' column contains numerical values (0.000) and the 'Limit' column contains '0 gal(US)'. The rows are: 'Supply:', 'V/P:', 'Regulator:', 'Flowmeter:', 'Valve 1:', 'Valve 2:', 'Valve 3:', and 'Valve 4:'. A vertical scroll bar on the right side of the table has a '3' next to it.

	Volume	Limit
Supply:	0.000	0 gal(US)
V/P:	0.000	0 gal(US)
Regulator:	0.000	0 gal(US)
Flowmeter:	0.000	0 gal(US)
Valve 1:	0.000	0 gal(US)
Valve 2:	0.000	0 gal(US)
Valve 3:	0.000	0 gal(US)
Valve 4:	0.000	0 gal(US)

Swirl X Screen

There is one Swirl X screen for each installed swirl dispenser. This screen displays the following items:

- Swirl Enable signal from the automation interface
- Speed command voltage from automation interface
- Actual and requested speed
- Active time and maintenance advisory limit

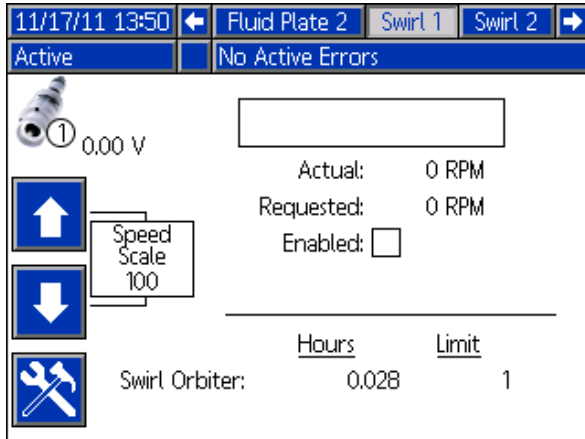

Press to scroll through each event report screen.

11/17/11 13:51					Jobs	Events	Errors	Home
Active		No Active Errors						
Date	Time	Code	Description					
11/17/11	13:51	EBD2-R	Maint. Mode Exited-SW2	18				
11/17/11	13:51	EAD2-R	Maint. Mode Entered-SW2	19				
11/17/11	13:50	EBD1-R	Maint. Mode Exited-SW1	20				
11/17/11	13:50	EAD1-R	Maint. Mode Entered-SW1	1				
11/17/11	13:50	EBC2-R	Maint. Mode Exited-FP2	2				
11/17/11	13:50	EAC2-R	Maint. Mode Entered-FP2	3				
11/17/11	13:49	EBD1-R	Maint. Mode Exited-SW1	4				
11/17/11	13:49	EBC1-R	Maint. Mode Exited-FP1					
11/17/11	13:49	EAD1-R	Maint. Mode Entered-SW1					
11/17/11	13:49	EAC1-R	Maint. Mode Entered-FP1					

Error Report Screens

The error report screens display a chronological list of system errors. These screens display the last 200 errors. Each error report screen displays the date, time, error code, and description for each error. See **Errors**, page 66, for more information on errors, a list of error codes, and information on error troubleshooting.

Press to scroll through each error report screen.

11/17/11 13:51					Events	Errors	Home
Active		No Active Errors					
Date	Time	Code	Description				
11/17/11	13:42	CAC2-A	Gateway Comm. Error-FP2	18			
11/17/11	13:42	CAC1-A	Gateway Comm. Error-FP1	19			
11/17/11	13:40	WBD2-A	Swirl Motor Fault-SW2	20			
11/17/11	13:40	CR42-A	Valve 4 Swirl Comm Error-FP2	1			
11/17/11	13:40	CR12-A	Valve 1 Swirl Comm Error-FP2	2			
11/17/11	13:39	P6D1-A	Outlet Pressure Sensor-FP1	3			
11/17/11	13:38	CBR2-A	Comm. Error-SW2	4			
11/17/11	13:38	CBD2-A	Comm. Error-FP2				
11/17/11	13:36	P6D1-A	Outlet Pressure Sensor-FP1				

Job Report Screens

The job report screens store and display a chronological list of 180 jobs performed by the system. Each job record includes the date and time the job was completed; the style dispensed; the error percentage; and the target, requested, and actual dispense volumes.

Press to scroll through each job report screen.

12/13/11 14:21					Swirl 2	Jobs	Events	Errors
Active		No Active Errors						
Date	Time	Target	Actual					
Dispenser	Style	Requested	% Error					
12/07/11	12:19	10.0	0.0	28				
2	1	0.0	0.0 %	29				
12/07/11	12:18	10.0	0.0	30				
2	1	10.0	100.0 %	1				
12/07/11	12:17	0.0	0.0	2				
2	1	0.0	0.0 %	3				
12/07/11	12:17	0.0	0.0	4				
2	1	0.0	0.0 %					
12/07/11	12:14	10.0 cc	0.0 cc					
1	1	10.0 cc	100.0 %					
12/07/11	12:12	10.0 cc	0.0 cc					
1	1	10.0 cc	100.0 %					

Event Report Screens

The event report screens display a chronological list of system events. These screens display the last 200 events. Each event report screen displays the date, time, event code, and description for each event.

Appendix B - Discrete Gateway Module (DGM) Connection Details

D-Sub Cable 123793

The D-sub cable 123793 is only compatible with single fluid plate systems. Systems with 2 fluid plates must use cable 123792 and breakout board 123783.

The cable length of interface cable assembly 123793 is 50 ft (15.2 m). The following table identifies the cable interface signals.

NOTE: See **Appendix D - I/O Signal Descriptions**, page 138, for I/O signal descriptions.

Wire Color	Description	Pin Type	D-Sub Pin No.
Green/Yellow	Isolated Logic Power Supply	Supply	51 and 27
Gray	Isolated Logic GND	Supply	70
Blue/Green	Dispense Ready	Digital Output	9
Brown/Green	Dispense Error*	Digital Output	11
Blue/Orange	Dispense In Process	Digital Output	12
White	Dispense Purge	Digital Output	15
Blue	Dispense Remote Start	Digital Output	16
White/Yellow	Style Bit 1	Digital Input	52
Blue/Yellow	Style Bit 2	Digital Input	53
Brown/Yellow	Style Bit 3	Digital Input	54
Black/Red	Style Bit 4	Digital Input	55
White/Red	Style Strobe	Digital Input	56
Blue/Red	Dispense Complete	Digital Input	57
Brown/Red	Error Reset	Digital Input	58
Black	Remote Start/Purge	Digital Input	59
Black/Gray	Dispense Valve 1	Digital Input	73
Brown/Orange	Dispense Valve 2	Digital Input	74
Brown	Command Value	Analog Input	1
Black/Yellow	Analog GND	Analog Input	2
White/Gray	---		3
Blue/Gray	Swirl 1 Speed Command ♦	Analog Input	21
Brown/Gray	Swirl 2 Speed Command ♦	Analog Input	23
White/Orange	Dispense Valve 3/ Swirl 1 Enable♦	Digital Input	75
Black/Orange	Dispense Valve 4/ Swirl 2 Enable♦	Digital Input	76
Black/Green	Digital CMD 1	Digital Input	77
White/Green	Digital CMD 2	Digital Input	78
Orange	---		N/C

♦ Swirl-related inputs apply only to systems with Swirl Dispensers.

* Dispense Error may be active high or low, depending on the setting on the Gateway setup screen. See **Discrete Gateway (Automation) Setup Screen**, page 104.

D-Sub Cable 123792 and Breakout Board 123783

The cable length of the interface cable assembly 123792 is 50 ft (15.2 m). The following table identifies the pin assignments for the 78-pin breakout board.

NOTE: See **Appendix D - I/O Signal Descriptions** on page 138.

D-Sub Pin No.	Description	Pin Type	Voltage (Vdc)
1	Command Value (Fluid Plate 1)	Analog In	0 - 10
2	Command Value Ground (Fluid Plate 1)	Analog In Ground	0
3	Command Value (Fluid Plate 2)	Analog In	0 - 10
4	Command Value Ground (Fluid Plate 2)	Analog In Ground	0
5			
6			
7			
8			
9	◆ Dispense Ready	Digital Out - Bank 1	0 - voltage connected to Pin 27
10	◆† Dispense Alarm/Error on Data	Digital Out - Bank 1	0 - voltage connected to Pin 27
11	◆† Dispense Error	Digital Out - Bank 1	0 - voltage connected to Pin 27
12	◆ Dispense In Process	Digital Out - Bank 1	0 - voltage connected to Pin 27
13	◆ Dispense Volume OK	Digital Out - Bank 1	0 - voltage connected to Pin 27
14	Fluid Plate Selected	Fluid Plate Selected	Fluid Plate Selected
15	◆ Dispense Purge	Digital Out - Bank 1	0 - voltage connected to Pin 27
16	◆ Dispense Remote Start	Digital Out - Bank 1	0 - voltage connected to Pin 27
17	◆ * Data 1	Digital Out - Bank 2	0 - voltage connected to Pin 68
18	◆ * Data 2	Digital Out - Bank 2	0 - voltage connected to Pin 68
19	◆ * Data 4	Digital Out - Bank 2	0 - voltage connected to Pin 68
20	◆ * Data 8	Digital Out - Bank 2	0 - voltage connected to Pin 68
21	Swirl 1 Speed Command	Analog In	0 - 10
22	Swirl 1 Speed Command Ground	Analog In Ground	0
23	Swirl 2 Speed Command	Analog In	0 - 10
24	Swirl 2 Speed Command Ground	Analog In Ground	0
25			
26			
27	Digital Out Supply - Bank 1	Isolated Logic Supply V+	10-30
28	◆ * Data 16	Digital Out - Bank 2	0 - voltage connected to Pin 68
29	◆ * Data 32	Digital Out - Bank 2	0 - voltage connected to Pin 68
30	◆ * Data 64	Digital Out - Bank 2	0 - voltage connected to Pin 68
31	◆ * Data 128	Digital Out - Bank 2	0 - voltage connected to Pin 68
32	◆ * Data 256	Digital Out - Bank 3	0 - voltage connected to Pin 69
33	◆ * Data 512	Digital Out - Bank 3	0 - voltage connected to Pin 69
34	◆ * Data 1024	Digital Out - Bank 3	0 - voltage connected to Pin 69
35	◆ * Data 2048	Digital Out - Bank 3	0 - voltage connected to Pin 69
36	◆ * Data 4096	Digital Out - Bank 3	0 - voltage connected to Pin 69
37	◆ * Data 8192	Digital Out - Bank 3	0 - voltage connected to Pin 69
38	◆ * Data 16384	Digital Out - Bank 3	0 - voltage connected to Pin 69
39	◆ * Data 32768	Digital Out - Bank 3	0 - voltage connected to Pin 69
40	Swirl 1 Actual Speed	Analog Out	0 - 10
41	Swirl 1 Actual Speed Ground	Analog Out Ground	0
42	Swirl 2 Actual Speed	Analog Out	0 - 10
43	Swirl 2 Actual Speed Ground	Analog Out Ground	0
44 - 50			
51	Isolated Logic Power Supply	Isolated Logic Supply V+	10-30
52	Style Bit 1	Digital In	0-30
53	Style Bit 2	Digital In	0-30
54	Style Bit 3	Digital In	0-30
55	Style Bit 4	Digital In	0-30
56	Style Strobe Fluid Plate 1	Digital In	0-30

D-Sub Pin No.	Description	Pin Type	Voltage (Vdc)
57	◆ Dispense Complete	Digital In	0-30
58	◆ Error Reset	Digital In	0-30
59	◆ Remote Start/Purge	Digital In	0-30
60 -67			
68	Digital Out Supply - Bank 2	Isolated Logic Supply V+	10-30
69	Digital Out Supply - Bank 3	Isolated Logic Supply V+	10-30
70	Isolated Logic GND	Isolated Ground	0
71	Style Strobe Fluid Plate 2	Digital In	0-30
72	◆ Fluid Plate Selector	Digital In	0-30
73	1 installed fluid plate, no swirl: Fluid Plate 1, Dispense Valve 1 2 installed fluid plates, no swirl: Fluid Plate 1, Dispense Valve 1 1 installed fluid plate, one or more swirl: Fluid Plate 1, Dispense Valve 1 2 installed fluid plates, one or more swirl: Fluid Plate 1, Dispense Valve 1	Digital In	0-30
74	1 installed fluid plate, no swirl: Fluid Plate 1, Dispense Valve 2 2 installed fluid plates, no swirl: Fluid Plate 1, Dispense Valve 2 1 installed fluid plate, one or more swirl: Fluid Plate 1, Dispense Valve 2 2 installed fluid plates, one or more swirl: Fluid Plate 2, Dispense Valve 1	Digital In	0-30
75	1 installed fluid plate, no swirl: Fluid Plate 1, Dispense Valve 3 2 installed fluid plates, no swirl: Fluid Plate 2, Dispense Valve 1 1 installed fluid plate, one or more swirl: Swirl 1 Enable 2 installed fluid plates, one or more swirl: Swirl 1 Enable	Digital In	0-30
76	1 installed fluid plate, no swirl: Fluid Plate 1, Dispense Valve 4 2 installed fluid plates, no swirl: Fluid Plate 2, Dispense Valve 2 1 installed fluid plate, one or more swirl: Swirl 2 Enable 2 installed fluid plates, one or more swirl: Swirl 2 Enable	Digital In	0-30
77	Digital CMD 1	Digital In	0-30
78	Digital CMD 2	Digital In	0-30

* 16-bit data outputs contain either volume or error information depending on state of dispense alarm/error on data.

- ◆ Fluid plate selector input (pin 72) toggles the plate to which these inputs and outputs will apply:
Pin 72 = 0: Inputs and outputs apply to fluid plate 1.
Pin 72 = 1: Inputs and outputs apply to fluid plate 2.

† Alarm and Error signals may be active high or low, depending on the setting on the Gateway setup screen. See **Discrete Gateway (Automation) Setup Screen**, page 104.

Pin References

NOTE: To avoid ground loops and noise immunity issues, do not ground the shield of the D-subminiature connector cable; it is already grounded through the mounting screw on the base of the DGM.

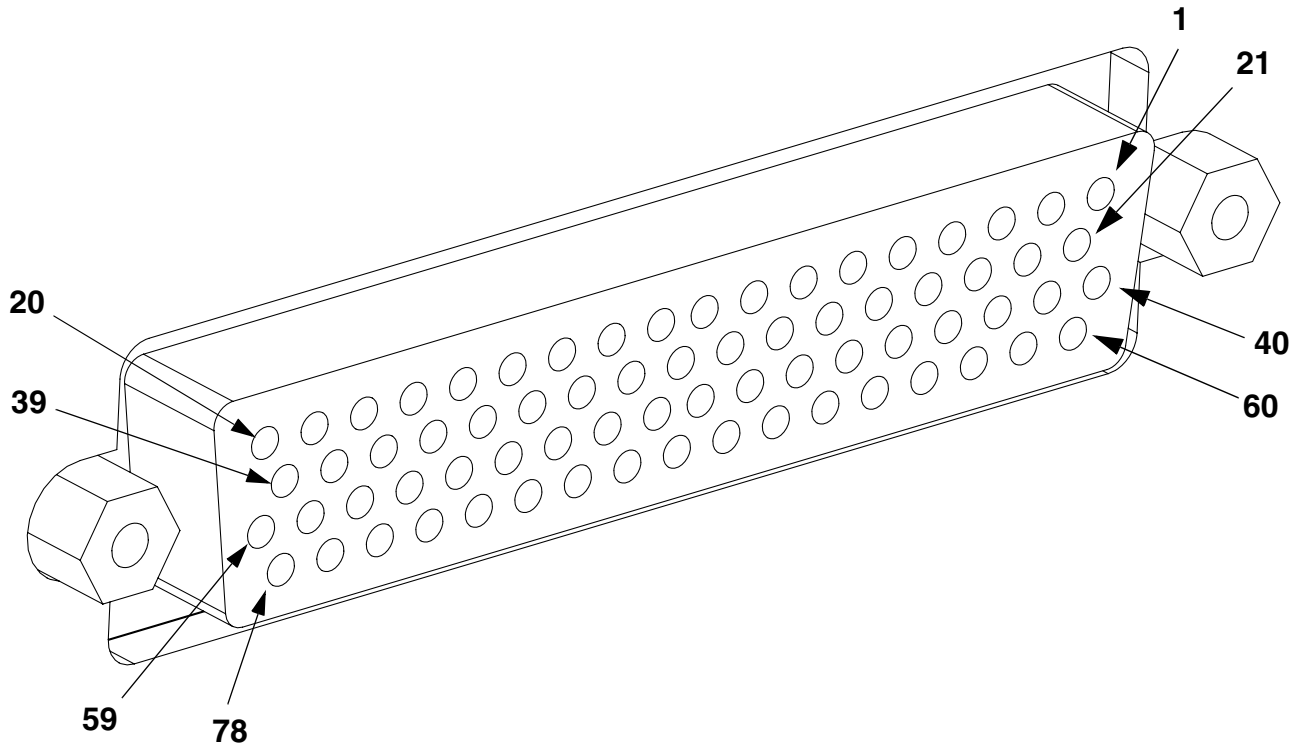
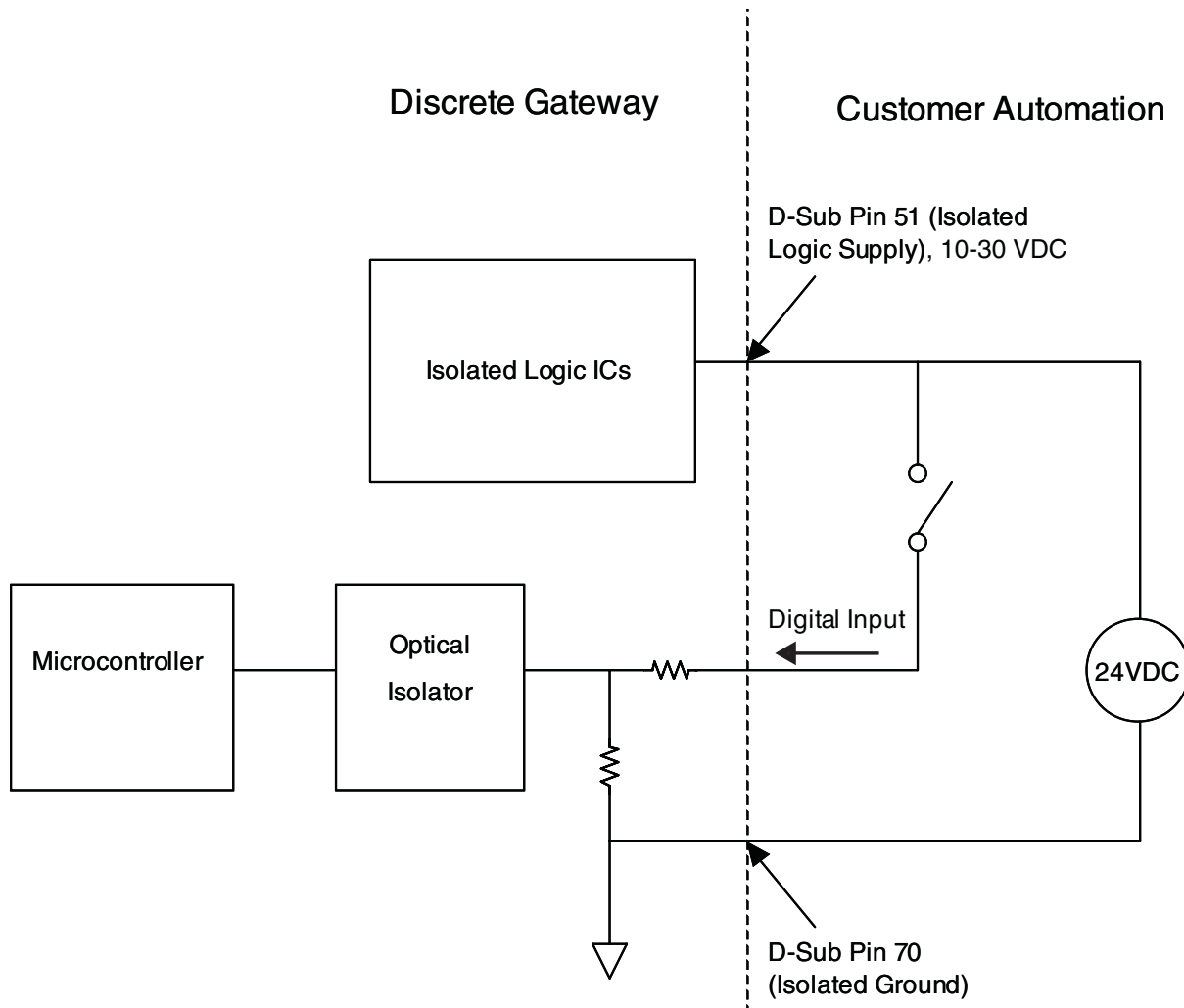

FIG. 68: D-Subminiature Connector - Pin References

DGM Digital Input

The digital inputs function only when power is supplied to pin 51 and there is a ground connection to pin 70. See **Pin References**, page 118, for details. The digital input is rated at 0-30 Vdc, and requires an NEC Class 2 power supply connected to pin 51. The DGM provides optical isolation as shown in the following illustration.

- Pins: 52 – 59, 71-78
- Type: Sinking
- Maximum current draw: 3.6 mA



DGM Digital Outputs

The digital outputs function only when power is supplied to pins 27, 68, and 69 and there is a ground connection to pin 70. See **Pin References**, page 118, for details. The digital output is rated at 0-30 Vdc, and requires an NEC Class 2 power supply connected to pin 27 for supply bank 1, pin 69 for supply bank 2, and pin 68 for supply bank 3. The DGM provides optical isolation as shown in the following illustration.

- Pins: 9-20, 28-39
- Type: Sourcing
- Maximum continuous current output: 350 mA (sourced from customer supply)
- Recommended continuous current: 100 mA

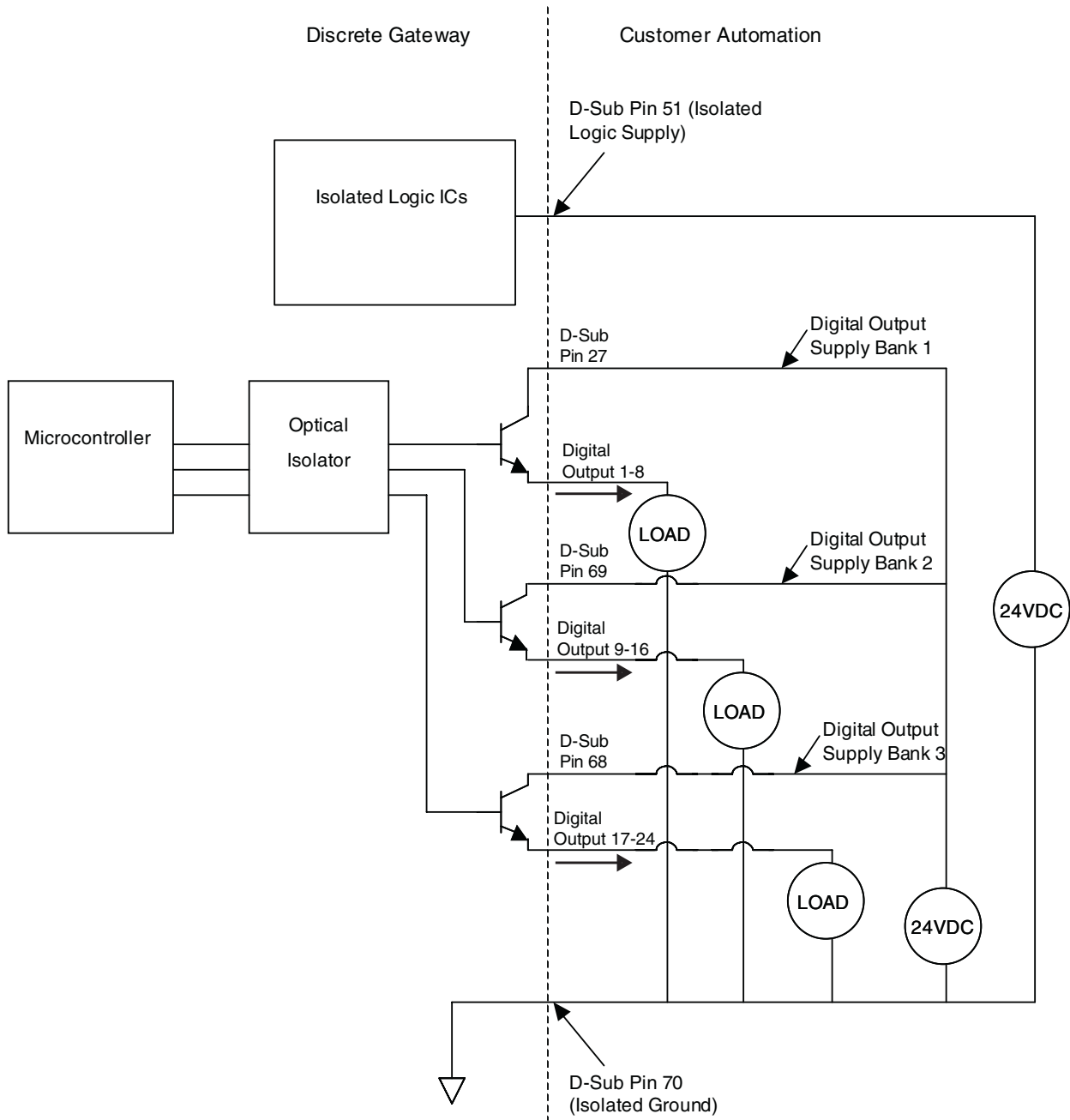

DGM Analog Inputs

The analog inputs function only when the DGM is connected to a power supply through the CAN connection. Each analog input has a corresponding reference (ground) pin. See **Pin References**, page 118, for details.

- Type: Sinking
- Voltage Rating: 0-10 Vdc
- Input Impedance: 20 k Ω

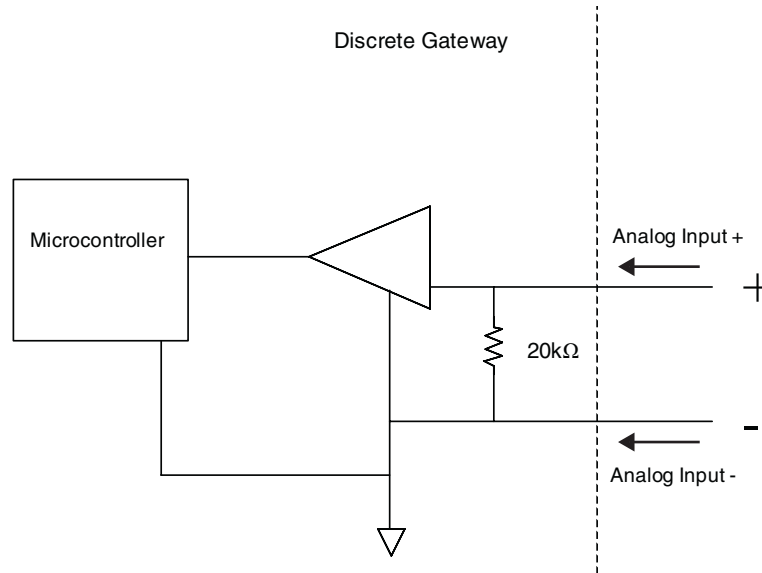

DGM Analog Outputs

The analog outputs function only when the DGM is connected to a power supply through the CAN connection. Each analog output has a corresponding reference (ground) pin. See **Pin References**, page 118, for details.

- Type: Sourcing
- Voltage Rating: 0-10 Vdc, 10 mA at 10 Vdc

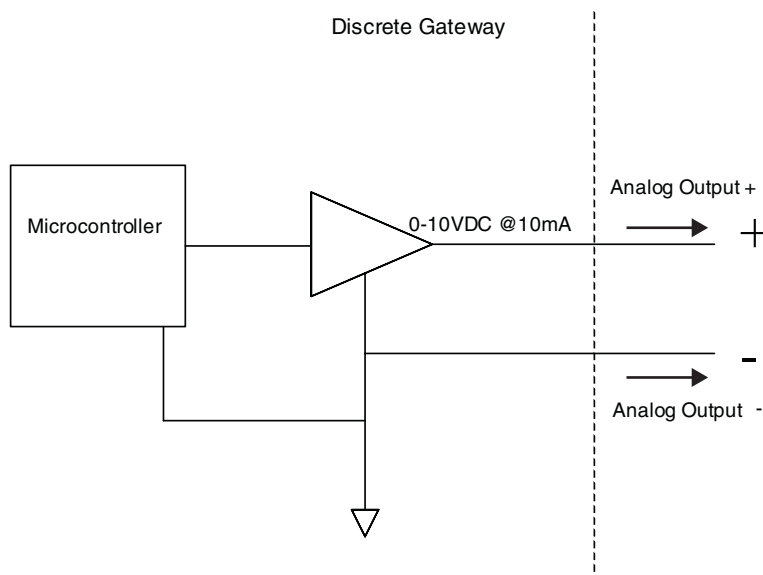

Appendix C - Communications Gateway Module (CGM) Connection Details

Install Fieldbus Connections

Connect cables to fieldbus per fieldbus standards.

PROFINET

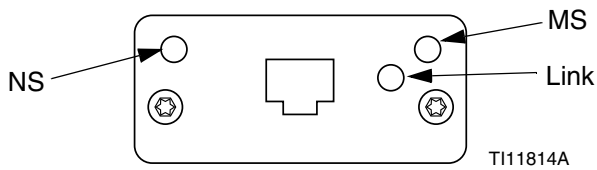

Fig. 69: PROFINET Fieldbus Connections

The Ethernet interface operates at 100Mbit, full duplex, as required by PROFINET. The Ethernet interface is auto-polarity sensing and auto-crossover capable.

Network Status (NS)

State	Description	Comments
Off	Offline	<ul style="list-style-type: none"> No power No connection with IO Controller
Green	On-line, (RUN)	<ul style="list-style-type: none"> Connection with IO Controller established IO Controller with RUN state
Flashing Green	On-line, (STOP)	<ul style="list-style-type: none"> Connection with IO Controller established IO Controller in STOP state

Module Status (MS)

State	Description	Comments
Off	Not initialized	No power or module in "SETUP" or "NW_INIT" state
Green	Normal operation	Diagnostic event(s) present
Flashing Green	Initialized, diagnostic event(s) present	Used by engineering tools to identify node on network
Red	Exception error	Module in state "EXCEPTION"
Red (1 flash)	Configuration error	Expected Identification differs from Real Identification
Red (2 flashes)	IP Address not set	Set IP address via system monitor or DNS server
Red (3 flashes)	Station Name not set	Set Station Name via system monitor
Red (4 flashes)	Major Internal Error	Cycle system power; replace module

Link/Activity (Link)

State	Description
Off	No Link, no communication present
Green	Link established, no communication present
Green, flashing	Link established, communication present

EtherNet/IP

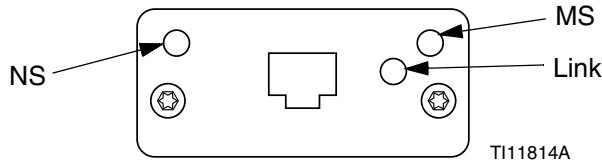

FIG. 70: EtherNet/IP Fieldbus Connections

The Ethernet interface operates at 100Mbit, full duplex, as required by PROFINET. The Ethernet interface is auto-polarity sensing and auto-crossover capable.

Network Status (NS)

State	Description
Off	No power or no IP address
Green	On-line, one or more connections established (CIP Class 1 or 3)
Flashing Green	On-line, no connections established
Red	Duplicate IP address, FATAL error
Flashing Red	One or more connections timed out (CIP Class 1 or 3)

Module Status (MS)

State	Description
Off	No power
Green	Controlled by a Scanner in Run state
Flashing Green	Not configured, or Scanner in Idle state
Red	Major fault (EXCEPTION-state, FATAL error etc.)
Flashing Red	Recoverable fault(s)

LINK/Activity (Link)

State	Description
Off	No link, no activity
Green	Link established
Flashing Green	Activity

DeviceNet

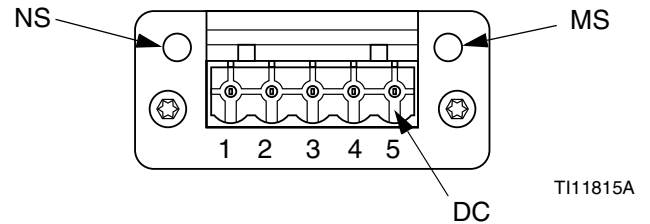

FIG. 71: DeviceNet Fieldbus Connections

Network Status (NS)

State	Description
Off	Not online / No power
Green	On-line, one or more connections are established
Flashing Green (1 Hz)	On-line, no connections established
Red	Critical link failure
Flashing Red (1 Hz)	One or more connections timed-out
Alternating Red/Green	Self test

Module Status (MS)

State	Description
Off	No power or not initialized
Green	Initialized
Flashing Green (1 Hz)	Missing or incomplete configuration, device needs commissioning
Red	Unrecoverable Fault(s)
Flashing Red (1 Hz)	Recoverable Fault(s)
Alternating Red/Green	Self test

DeviceNet Connector (DC)

Pin	Signal	Description
1	V-	Negative bus supply voltage
2	CAN_L	CAN low bus line
3	SHIELD	Cable shield
4	CAN_H	CAN high bus line
5	V+	Positive bus supply voltage

PROFIBUS

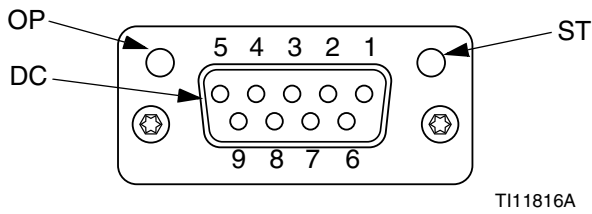

FIG. 72: PROFIBUS Fieldbus Connections

Operation Mode (OP)

State	Description
Off	Not online / No power
Green	On-line, data exchange
Flashing Green	On-line, clear
Flashing Red (1 flash)	Parameterization error
Flashing Red (2 flashes)	PROFIBUS Configuration error

Status Mode (ST)

State	Description
Off	No power or not initialized
Green	Initialized
Flashing Green	Initialized, diagnostic event(s) present
Red	Exception error

PROFIBUS Connector (DC)

Pin	Signal	Description
1	-	-
2	-	-
3	B Line	Positive RxD/TxD, RS485 level
4	RTS	Request to send
5	GND Bus	Ground (isolated)
6	+5V Bus Output	+5V termination power (isolated)
7	-	-
8	A Line	Negative RxD/TxD, RS485 level
9	-	-
Housing	Cable Shield	Internally connected to the Anybus protective earth via cable shield filters according to the PROFIBUS standard.

CGM I/O Data Map

See Appendix D - I/O Signal Descriptions on page 138.

Automation Inputs (signals from PCF)

Byte	Input Bit	Description	Zone
0	I00	Dispenser (Fluid Plate) Ready	Fluid Plate 1
	I01	Dispenser (Fluid Plate) No Alarm	
	I02	Dispense No Error	
	I03	Dispense in Process	
	I04	Dispense Volume OK	
	I05	---	
	I06	Dispenser (Fluid Plate) Purge Request	
1	I07	Dispenser (Fluid Plate) Remote Start / Purge In Process	Fluid Plate 1
	I08	Pressure Units - Bit 0	
	I09	Pressure Units - Bit 1	
	I10	---	
	I11	---	
	I12	---	
	I13	---	
	I14	---	
2	I15	---	Fluid Plate 1
	I16	---	
	I17	---	
	I18	---	
	I19	---	
	I20	---	
	I21	---	
3	I22	---	Fluid Plate 1
	I23	---	
	I24	Error - 1	
	I25	Error - 2	
	I26	Error - 4	
	I27	Error - 8	
	I28	Error - 16	
4	I29	Error - 32	Fluid Plate 2
	I30	Error - 64	
	I31	Error - 128	
	I32	Dispenser (Fluid Plate) Ready	
	I33	Dispenser (Fluid Plate) No Alarm	
	I34	Dispense No Error	
	I35	Dispense in Process	
10	I36	Dispense Volume OK	Fluid Plate 3
	I37	---	
	I38	Dispenser (Fluid Plate) Purge Request	
	I39	Dispenser (Fluid Plate) Remote Start / Purge In Process	

Byte	Input Bit	Description	Zone
5	I40	Pressure Units - Bit 0	Fluid Plate 2
	I41	Pressure Units - Bit 1	
	I42	---	
	I43	---	
	I44	---	
	I45	---	
	I46	---	
6	I47	---	Fluid Plate 2
	I48	---	
	I49	---	
	I50	---	
	I51	---	
	I52	---	
	I53	---	
	I54	---	
	I55	---	
7	I56	Error - 1	Fluid Plate 2
	I57	Error - 2	
	I58	Error - 4	
	I59	Error - 8	
	I60	Error - 16	
	I61	Error - 32	
	I62	Error - 64	
8	I63	Error - 128	Fluid Plate 3
	I64	Dispenser (Fluid Plate) Ready	
	I65	Dispenser (Fluid Plate) No Alarm	
	I66	Dispense No Error	
	I67	Dispense in Process	
	I68	Dispense Volume OK	
	I69	---	
9	I70	Dispenser (Fluid Plate) Purge Request	Fluid Plate 3
	I71	Dispenser (Fluid Plate) Remote Start / Purge In Process	
	I72	Pressure Units - Bit 0	
	I73	Pressure Units - Bit 1	
	I74	---	
	I75	---	
	I76	---	
	I77	---	
	I78	---	
	I79	---	
10	I80	---	Fluid Plate 3
	I81	---	
	I82	---	
	I83	---	
	I84	---	
	I85	---	
	I86	---	
I87	---		

Appendix C - Communications Gateway Module (CGM) Connection Details

Byte	Input Bit	Description	Zone
11	I88	Error - 1	Fluid Plate 3
	I89	Error - 2	
	I90	Error - 4	
	I91	Error - 8	
	I92	Error - 16	
	I93	Error - 32	
	I94	Error - 64	
	I95	Error - 128	
12	I96	Dispenser (Fluid Plate) Ready	Fluid Plate 4
	I97	Dispenser (Fluid Plate) No Alarm	
	I98	Dispense No Error	
	I99	Dispense in Process	
	I100	Dispense Volume OK	
	I101	---	
	I102	Dispenser (Fluid Plate) Purge Request	
13	I103	Dispenser (Fluid Plate) Remote Start / Purge In Process	Fluid Plate 4
	I104	Pressure Units - Bit 0	
	I105	Pressure Units - Bit 1	
	I106	---	
	I107	---	
	I108	---	
	I109	---	
	I110	---	
14	I111	---	Fluid Plate 4
	I112	---	
	I113	---	
	I114	---	
	I115	---	
	I116	---	
	I117	---	
15	I118	---	Fluid Plate 4
	I119	---	
	I120	Error - 1	
	I121	Error - 2	
	I122	Error - 4	
	I123	Error - 8	
	I124	Error - 16	
16	I125	Error - 32	All Fluid Plates/Swirls
	I126	Error - 64	
	I127	Error - 128	
	I128	Command Interface - Value - Bit 0 See CGM Command Interface on page 131 for command interface details.	
	I129	Command Interface - Value - Bit 1	
	I130	Command Interface - Value - Bit 2	
	I131	Command Interface - Value - Bit 3	
	I132	Command Interface - Value - Bit 4	
I133	Command Interface - Value - Bit 5		
I134	Command Interface - Value - Bit 6		
I135	Command Interface - Value - Bit 7		

Byte	Input Bit	Description	Zone
17	I136	Command Interface - Value - Bit 8	All Fluid Plates/Swirls
	I137	Command Interface - Value - Bit 9	
	I138	Command Interface - Value - Bit 10	
	I139	Command Interface - Value - Bit 11	
	I140	Command Interface - Value - Bit 12	
	I141	Command Interface - Value - Bit 13	
	I142	Command Interface - Value - Bit 14	
	I143	Command Interface - Value - Bit 15	
18	I144	Command Interface - Value - Bit 16	All Fluid Plates/Swirls
	I145	Command Interface - Value - Bit 17	
	I146	Command Interface - Value - Bit 18	
	I147	Command Interface - Value - Bit 19	
	I148	Command Interface - Value - Bit 20	
	I149	Command Interface - Value - Bit 21	
	I150	Command Interface - Value - Bit 22	
19	I151	Command Interface - Value - Bit 23	All Fluid Plates/Swirls
	I152	Command Interface - Value - Bit 24	
	I153	Command Interface - Value - Bit 25	
	I154	Command Interface - Value - Bit 26	
	I155	Command Interface - Value - Bit 27	
	I156	Command Interface - Value - Bit 28	
	I157	Command Interface - Value - Bit 29	
20	I158	Command Interface - Value - Bit 30	All Fluid Plates/Swirls
	I159	Command Interface - Value - Bit 31	
	I160	Command Interface Status - Command Active	
	I161	Command Interface Status - Command Success	
	I162	Command Interface Status - Command Failure	
	I163	Command Interface Status - Value Coerced	
	I164	---	
21-25	I165	---	---
	I166	---	
	I167	---	
	I168-I207	---	

Automation Outputs (signals to PCF)

Byte	Output Bit	Description	Zone
0	O00	Style Strobe	Fluid Plate 1
	O01	Dispense Complete	
	O02	Dispense Valve 1 On	
	O03	Dispense Valve 2 On	
	O04	Dispense Valve 3 On	
	O05	Dispense Valve 4 On	
	O06	Error Reset / Cancel Job	
	O07	Remote Start / Purge	
1	O08	Swirl Enable	Swirl 1
	O09	---	
	O10	---	
	O11	---	
	O12	---	
	O13	---	
	O14	---	
	O15	---	
2	O16	Style - 1	Fluid Plate 1
	O17	Style - 2	
	O18	Style - 4	
	O19	Style - 8	
	O20	Style - 16	
	O21	Style - 32	
	O22	Style - 64	
	O23	Style - 128	
3	O24	Dispense Valve 1 Precharge On	Fluid Plate 1
	O25	Dispense Valve 2 Precharge On	
	O26	Dispense Valve 3 Precharge On	
	O27	Dispense Valve 4 Precharge On	
	O28	---	
	O29	---	
	O30	---	
	O31	---	
4	O32	Command Value - 1	Fluid Plate 1
	O33	Command Value - 2	
	O34	Command Value - 4	
	O35	Command Value - 8	
	O36	Command Value - 16	
	O37	Command Value - 32	
	O38	Command Value - 64	
	O39	Command Value - 128	
5	O40	Command Value - 256	Fluid Plate 1
	O41	Command Value - 512	
	O42	Command Value - 1024	
	O43	Command Value - 2048	
	O44	---	
	O45	---	
	O46	---	
	O47	---	

Byte	Output Bit	Description	Zone
6	O48	Swirl Command Value - 1	Swirl 1
	O49	Swirl Command Value - 2	
	O50	Swirl Command Value - 4	
	O51	Swirl Command Value - 8	
	O52	Swirl Command Value - 16	
	O53	Swirl Command Value - 32	
	O54	Swirl Command Value - 64	
	O55	Swirl Command Value - 128	
7	O56	Swirl Command Value - 256	Swirl 1
	O57	Swirl Command Value - 512	
	O58	Swirl Command Value - 1024	
	O59	Swirl Command Value - 2048	
	O60	---	
	O61	---	
	O62	---	
	O63	---	
8	O64	Style Strobe	Fluid Plate 2
	O65	Dispense Complete	
	O66	Dispense Valve 1 On	
	O67	Dispense Valve 2 On	
	O68	Dispense Valve 3 On	
	O69	Dispense Valve 4 On	
	O70	Error Reset / Cancel Job	
	O71	Remote Start / Purge	
9	O72	Swirl Enable	Swirl 2
	O73	---	
	O74	---	
	O75	---	
	O76	---	
	O77	---	
	O78	---	
	O79	---	
10	O80	Style - 1	Fluid Plate 2
	O81	Style - 2	
	O82	Style - 4	
	O83	Style - 8	
	O84	Style - 16	
	O85	Style - 32	
	O86	Style - 64	
	O87	Style - 128	
11	O88	Dispense Valve 1 Precharge On	Fluid Plate 2
	O89	Dispense Valve 2 Precharge On	
	O90	Dispense Valve 3 Precharge On	
	O91	Dispense Valve 4 Precharge On	
	O92	---	
	O93	---	
	O94	---	
	O95	---	

Appendix C - Communications Gateway Module (CGM) Connection Details

Byte	Output Bit	Description	Zone
12	O96	Command Value - 1	Fluid Plate 2
	O97	Command Value - 2	
	O98	Command Value - 4	
	O99	Command Value - 8	
	O100	Command Value - 16	
	O101	Command Value - 32	
	O102	Command Value - 64	
	O103	Command Value - 128	
13	O104	Command Value - 256	Fluid Plate 2
	O105	Command Value - 512	
	O106	Command Value - 1024	
	O107	Command Value - 2048	
	O108	---	
	O109	---	
	O110	---	
14	O112	Swirl Command Value - 1	Swirl 2
	O113	Swirl Command Value - 2	
	O114	Swirl Command Value - 4	
	O115	Swirl Command Value - 8	
	O116	Swirl Command Value - 16	
	O117	Swirl Command Value - 32	
	O118	Swirl Command Value - 64	
	O119	Swirl Command Value - 128	
15	O120	Swirl Command Value - 256	Swirl 2
	O121	Swirl Command Value - 512	
	O122	Swirl Command Value - 1024	
	O123	Swirl Command Value - 2048	
	O124	---	
	O125	---	
	O126	---	
16	O128	Style Strobe	Fluid Plate 3
	O129	Dispense Complete	
	O130	Dispense Valve 1 On	
	O131	Dispense Valve 2 On	
	O132	Dispense Valve 3 On	
	O133	Dispense Valve 4 On	
	O134	Error Reset / Cancel Job	
	O135	Remote Start / Purge	
17	O136	Swirl Enable	Swirl 3
	O137	---	
	O138	---	
	O139	---	
	O140	---	
	O141	---	
	O142	---	
	O143	---	
18	O144	Style - 1	Fluid Plate 3
	O145	Style - 2	
	O146	Style - 4	
	O147	Style - 8	
	O148	Style - 16	
	O149	Style - 32	
	O150	Style - 64	
	O151	Style - 128	

Byte	Output Bit	Description	Zone
19	O152	Dispense Valve 1 Precharge On	Fluid Plate 3
	O153	Dispense Valve 2 Precharge On	
	O154	Dispense Valve 3 Precharge On	
	O155	Dispense Valve 4 Precharge On	
	O156	---	
	O157	---	
	O158	---	
	O159	---	
20	O160	Command Value - 1	Fluid Plate 3
	O161	Command Value - 2	
	O162	Command Value - 4	
	O163	Command Value - 8	
	O164	Command Value - 16	
	O165	Command Value - 32	
	O166	Command Value - 64	
	O167	Command Value - 128	
21	O168	Command Value - 256	Fluid Plate 3
	O169	Command Value - 512	
	O170	Command Value - 1024	
	O171	Command Value - 2048	
	O172	---	
	O173	---	
	O174	---	
	O175	---	
22	O176	Swirl Command Value - 1	Swirl 3
	O177	Swirl Command Value - 2	
	O178	Swirl Command Value - 4	
	O179	Swirl Command Value - 8	
	O180	Swirl Command Value - 16	
	O181	Swirl Command Value - 32	
	O182	Swirl Command Value - 64	
	O183	Swirl Command Value - 128	
23	O184	Swirl Command Value - 256	Swirl 3
	O185	Swirl Command Value - 512	
	O186	Swirl Command Value - 1024	
	O187	Swirl Command Value - 2048	
	O188	---	
	O189	---	
	O190	---	
	O191	---	
24	O192	Style Strobe	Fluid Plate 4
	O193	Dispense Complete	
	O194	Dispense Valve 1 On	
	O195	Dispense Valve 2 On	
	O196	Dispense Valve 3 On	
	O197	Dispense Valve 4 On	
	O198	Error Reset / Cancel Job	
	O199	Remote Start / Purge	
25	O200	Swirl Enable	Swirl 4
	O201	---	
	O202	---	
	O203	---	
	O204	---	
	O205	---	
	O206	---	
	O207	---	

Byte	Output Bit	Description	Zone
26	O208	Style - 1	Fluid Plate 4
	O209	Style - 2	
	O210	Style - 4	
	O211	Style - 8	
	O212	Style - 16	
	O213	Style - 32	
	O214	Style - 64	
27	O215	Style - 128	Fluid Plate 4
	O216	Dispense Valve 1 Precharge On	
	O217	Dispense Valve 2 Precharge On	
	O218	Dispense Valve 3 Precharge On	
	O219	Dispense Valve 4 Precharge On	
	O220	---	
	O221	---	
28	O222	---	Fluid Plate 4
	O223	---	
	O224	Command Value - 1	
	O225	Command Value - 2	
	O226	Command Value - 4	
	O227	Command Value - 8	
	O228	Command Value - 16	
29	O229	Command Value - 32	Fluid Plate 4
	O230	Command Value - 64	
	O231	Command Value - 128	
	O232	Command Value - 256	
	O233	Command Value - 512	
	O234	Command Value - 1024	
	O235	Command Value - 2048	
30	O236	---	Swirl 4
	O237	---	
	O238	---	
	O239	---	
	O240	Swirl Command Value - 1	
	O241	Swirl Command Value - 2	
	O242	Swirl Command Value - 4	
31	O243	Swirl Command Value - 8	Swirl 4
	O244	Swirl Command Value - 16	
	O245	Swirl Command Value - 32	
	O246	Swirl Command Value - 64	
	O247	Swirl Command Value - 128	
	O248	Swirl Command Value - 256	
	O249	Swirl Command Value - 512	
31	O250	Swirl Command Value - 1024	Swirl 4
	O251	Swirl Command Value - 2048	
	O252	---	
	O253	---	
	O254	---	
	O255	---	

Byte	Output Bit	Description	Zone
32	O256	Command Interface - Command - Bit 0 See CGM Command Interface on page 131 for command interface details.	All Fluid Plates/S wirls
	O257	Command Interface - Command - Bit 1	
	O258	Command Interface - Command - Bit 2	
	O259	Command Interface - Command - Bit 3	
	O260	Command Interface - Command - Bit 4	
	O261	Command Interface - Command - Bit 5	
	O262	Command Interface - Command - Bit 6	
33	O263	Command Interface - Command - Bit 7	All Fluid Plates/S wirls
	O264	Command Interface - Command - Bit 8	
	O265	Command Interface - Command - Bit 9	
	O266	Command Interface - Command - Bit 10	
	O267	Command Interface - Command - Bit 11	
	O268	Command Interface - Command - Bit 12	
	O269	Command Interface - Command - Bit 13	
34	O270	Command Interface - Command - Bit 14	All Fluid Plates/S wirls
	O271	Command Interface - Command - Bit 15	
	O272	Command Interface - Command - Bit 16	
34	O273	Command Interface - Command - Bit 17	All Fluid Plates/S wirls
	O274	Command Interface - Command - Bit 18	
	O275	Command Interface - Command - Bit 19	
	O276	---	
	O277	---	
	O278	---	
	O279	---	
35	O280-O287	---	---

Appendix C - Communications Gateway Module (CGM) Connection Details

Byte	Output Bit	Description	Zone
36	O288	Command Interface - Value - Bit 0 See CGM Command Interface on page 131 for command interface details.	All Fluid Plates/S wirls
	O289	Command Interface - Value - Bit 1	
	O290	Command Interface - Value - Bit 2	
	O291	Command Interface - Value - Bit 3	
	O292	Command Interface - Value - Bit 4	
	O293	Command Interface - Value - Bit 5	
	O294	Command Interface - Value - Bit 6	
	O295	Command Interface - Value - Bit 7	
37	O296	Command Interface - Value - Bit 8	All Fluid Plates/S wirls
	O297	Command Interface - Value - Bit 9	
	O298	Command Interface - Value - Bit 10	
	O299	Command Interface - Value - Bit 11	
	O300	Command Interface - Value - Bit 12	
	O301	Command Interface - Value - Bit 13	
	O302	Command Interface - Value - Bit 14	
38	O303	Command Interface - Value - Bit 15	All Fluid Plates/S wirls
	O304	Command Interface - Value - Bit 16	
	O305	Command Interface - Value - Bit 17	
	O306	Command Interface - Value - Bit 18	
	O307	Command Interface - Value - Bit 19	
	O308	Command Interface - Value - Bit 20	
	O309	Command Interface - Value - Bit 21	
39	O310	Command Interface - Value - Bit 22	All Fluid Plates/S wirls
	O311	Command Interface - Value - Bit 23	
	O312	Command Interface - Value - Bit 24	
	O313	Command Interface - Value - Bit 25	
	O314	Command Interface - Value - Bit 26	
	O315	Command Interface - Value - Bit 27	
	O316	Command Interface - Value - Bit 28	
	O317	Command Interface - Value - Bit 29	
O318	Command Interface - Value - Bit 30		
40	O319	Command Interface - Value - Bit 31	All Fluid Plates/S wirls
	O320	Command Interface - Control Bits - Read	
	O321	Command Interface - Control Bits - Write	
	O322	---	
	O323	---	
	O324	---	
	O325	---	
41	O326	---	---
	O327	---	
	O328- O335	---	

CGM Command Interface

NOTE: The CGM command interface is only available for fluid plates with 16 or 256 styles.

The CGM command interface utilizes bits in the **CGM I/O Data Map**, page 125, to support many additional functions that are not available in the other CGM I/O bits.

NOTE: When changes are made over the command interface, the ADM screen may not update immediately. It may be necessary to navigate away from the screen then back to it.

The CGM command interface uses automation output bits 256 to 327. These bits can be used to request the value of a current system setting (read) or change a system setting (write).

- Output bits 256-267 are used to identify the individual command. Each bit will have a single binary value to create the hex code listed in the commands table.
- Output bits 268-275 are used to identify the individual Fluid Plate or Swirl dispenser to which the commands will apply.
- Output bits 288-319 are used to identify the value of the command specified by bits 256-267 and 268-275.
- Output bit 321 identifies the command as a write command.
- Output bit 320 identifies the command as a read command.

The CGM command interface uses automation input bits 128-159 to read the current system values. It also uses input bits 160-163 to identify the status of commands:

- Bit 160: Command Active
- Bit 161: Command Success
- Bit 162: Command Failure
- Bit 163: Value Coerced

NOTE: If both output bits 320 (read) and 321 (write) are high during a command the result will be a command failure identified by input bit 162 (command failure) going high.

Examples

NOTE: See the timing diagram and tables starting on page 132 for detailed descriptions of the input and output bits.

Example 1: if output bits 256-275 are 0xB0203, output bits 288-319 are 0x0004, and output bit 321 is high, this means:

- The command relates to the purge period in minutes (0x__203)
- The command relates to fluid plate 1 (0xB0__)
- The command is a write command (bit 321 high)
- The value of the command is 4 (0x0004)

Combine these individual pieces to understand the command as a whole: *Change the purge period setting on fluid plate 1 to 4 minutes.*

Example 2: if output bits 256-275 are 0xB3212, input bits 288-319 are 0x0000, and output bit 320 is high, this means:

- The command relates to whether valve 1 is enabled (0x__212)
- The command relates to fluid plate 4 (0xB3__)
- The command is a read command (bit 320 high)
- The value of the command is 0 (0x0000)

Combined, this means: *Valve 1 on fluid plate 4 is disabled.*

Command Interface Timing Diagram

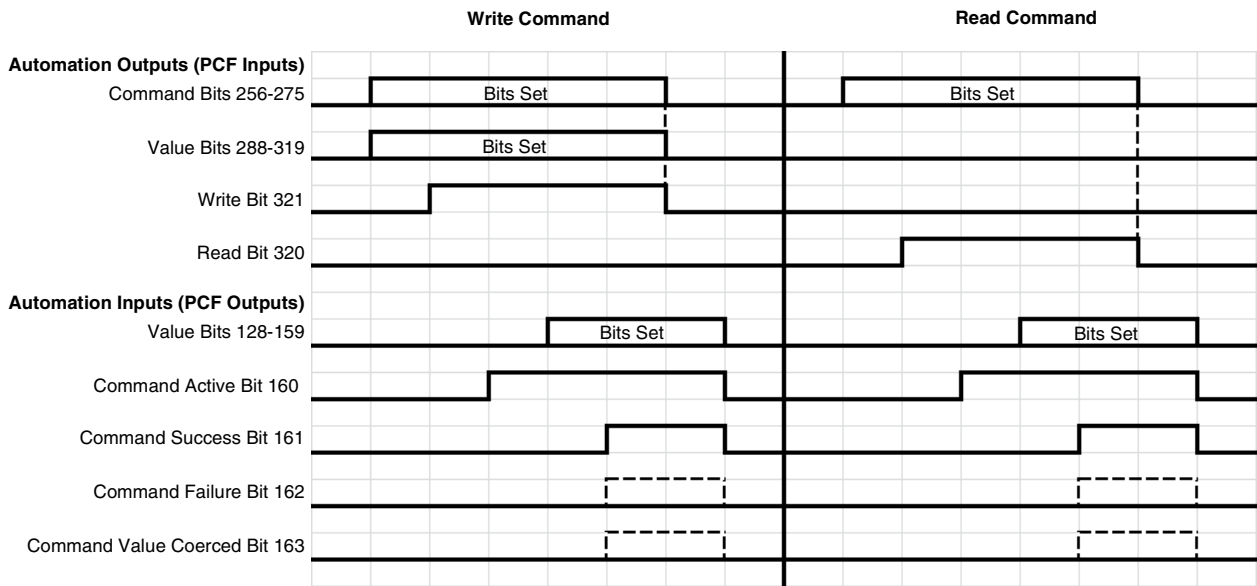

FIG. 73: CGM Command Interface Timing Diagram

Command Interface Write Operation

1. Set Command Identification Bits and Fluid Plate/Swirl Identification Bits to the desired values.
2. Set Value Bits (Output) with the value that is desired to be written.
3. Set Write Bit.
4. Wait for the Command Active Bit to become set. This indicates that an operation is in process.
5. Wait for the Command Success Bit, Command Failure Bit, or Command Value Coerced Bit to become set.

NOTE: The Value Bits (Input) now contain the value that was actually written.

6. Clear the Write Bit to end the write command operation.

Command Interface Read Operation

1. Set Command Identification Bits and Fluid Plate/Swirl Identification Bits to the desired values.
2. Set Read Bit.
3. Wait for the Command Active Bit to become set. This indicates that an operation is in process.

4. Wait for the Command Success Bit or Command Failure Bit to become set.

NOTE: If Command Success Bit has been set, valid data will be present within the Value Bits (Input).

5. Clear the Read Bit to end the read command operation.

Fluid Plate/Swirl Identification Commands

Output Bits 268-275	Description
0xB0	Fluid Plate 1
0xB1	Fluid Plate 2
0xB2	Fluid Plate 3
0xB3	Fluid Plate 4
0xE1	Swirl 1
0xE2	Swirl 2
0xE3	Swirl 3
0xE4	Swirl 4

Fluid Plate Commands

Output Bits 256-267	Description	Units *See Units Definitions, page 137	Read or Write
0x004	Software Part Number	STR_3_0	Read Only
0x005	Software Part Number	STR_7_4	Read Only
0x006	Software Part Number	STR_11_8	Read Only

Output Bits 256-267	Description	Units *See Units Definitions, page 137	Read or Write
0x007	Software Part Number	STR_15_12	Read Only
0x008	Software Version	Version	Read Only
0x0DD	Maintenance Units Type	Maintenance Units Enumeration	Read Only
0x0DF	Enabled Styles	###	Read Only
0x203	Purge Period	##### (minutes)	Read / Write
0x204	Dispense Trigger Source	Dispense Trigger Source Enumeration	Read / Write
0x208	Command Value Source	Command Value Source Enumeration	Read / Write
0x20F	Bead Scale	### (percent)	Read / Write
0x210	Job End Mode	Job End Mode Enumeration	Read / Write
0x211	Job End Delay Time	Integer (Seconds)	Read / Write
0x2B5	End Job On Alarm	Boolean	
0x212	Valve 1 Enable	Boolean	Read / Write
0x213	Valve 2 Enable	Boolean	Read / Write
0x214	Valve 3 Enable	Boolean	Read / Write
0x215	Valve 4 Enable	Boolean	Read / Write
0x216	Regulator On Delay	### (mS)	Read / Write
0x217	Regulator Off Delay	### (mS)	Read / Write
0x218	Valve 1 On Delay	### (mS)	Read / Write
0x219	Valve 2 On Delay	### (mS)	Read / Write
0x21A	Valve 3 On Delay	### (mS)	Read / Write
0x21B	Valve 4 On Delay	### (mS)	Read / Write
0x21C	Valve 1 Off Delay	### (mS)	Read / Write
0x21D	Valve 2 Off Delay	### (mS)	Read / Write
0x21E	Valve 3 Off Delay	### (mS)	Read / Write
0x21F	Valve 4 Off Delay	### (mS)	Read / Write
0x230	Flow Meter Type	Flow Meter Type Enumeration	Read / Write

Output Bits 256-267	Description	Units *See Units Definitions, page 137	Read or Write
0x231	Flow Meter K-Factor	##### (pulses/Liter, pulses/kg)	Read / Write
0x23C	Outlet Pressure Sensor User Offset	sint32; ##### (psi); ###.# (bar); ##.## (Mpa)	Read / Write
0x23D	Inlet Pressure Sensor User Offset	sint32; ##### (psi); ###.# (bar); ##.## (Mpa)	Read / Write
0x241	Maximum Outlet Pressure	uint32; ##### (psi); ###.# (bar); ##.## (Mpa)	Read / Write
0x244	Minimum Inlet Pressure	uint32; ##### (psi); ###.# (bar); ##.## (Mpa)	Read / Write
0x245	Maximum Inlet Pressure	uint32; ##### (psi); ###.# (bar); ##.## (Mpa)	Read / Write
0x248	Pressure Kp	#####.##	Read / Write
0x249	Pressure Ki	#####.##	Read / Write
0x247	Pressure Kd	#####.##	Read / Write
0x254	Bead Kp	#####.##	Read / Write
0x255	Bead Ki	#####.##	Read / Write
0x260	Regulator Time Advisory Limit	##### (hours)	Read / Write
0x262	Regulator Volume/Mass Advisory Limit	Volume: ##### (gal(US)); ##### (gal(UK)); ##### (Liters); Mass: ##### (lb), ##### (kg)	Read / Write
0x264	Flow meter Time Advisory Limit	##### (hours)	Read / Write
0x266	Flow meter Volume/Mass Advisory Limit	Volume: ##### (gal(US)); ##### (gal(UK)); ##### (Liters); Mass: ##### (lb), ##### (kg)	Read / Write
0x268	Supply Time Advisory Limit	##### (hours)	Read / Write
0x26A	Supply Volume/Mass Advisory Limit	Volume: ##### (gal(US)); ##### (gal(UK)); ##### (Liters); Mass: ##### (lb), ##### (kg)	Read / Write
0x26C	V/P Time Advisory Limit	##### (hours)	Read / Write

Appendix C - Communications Gateway Module (CGM) Connection Details

Output Bits 256-267	Description	Units *See Units Definitions, page 137	Read or Write
0x26E	V/P Volume/Mass Advisory Limit	Volume: ##### (gal(US)); ##### (gal(Uk)); ##### (Liters); Mass: ##### (lb), ##### (kg)	Read / Write
0x270	Valve 1 Time Advisory Limit	##### (hours)	Read / Write
0x271	Valve 2 Time Advisory Limit	##### (hours)	Read / Write
0x272	Valve 3 Time Advisory Limit	##### (hours)	Read / Write
0x273	Valve 4 Time Advisory Limit	##### (hours)	Read / Write
0x278	Valve 1 Volume/Mass Advisory Limit	Volume: ##### (gal(US)); ##### (gal(Uk)); ##### (Liters); Mass: ##### (lb), ##### (kg)	Read / Write
0x279	Valve 2 Volume/Mass Advisory Limit	Volume: ##### (gal(US)); ##### (gal(Uk)); ##### (Liters); Mass: ##### (lb), ##### (kg)	Read / Write
0x27A	Valve 3 Volume/Mass Advisory Limit	Volume: ##### (gal(US)); ##### (gal(Uk)); ##### (Liters); Mass: ##### (lb), ##### (kg)	Read / Write
0x27B	Valve 4 Volume/Mass Advisory Limit	Volume: ##### (gal(US)); ##### (gal(Uk)); ##### (Liters); Mass: ##### (lb), ##### (kg)	Read / Write
0x283	Swirl Fault Error Type	Error Type Enumeration 2	
0x284	Low Flow Rate Error Type	Error Type Enumeration 1	Read / Write
0x285	High Flow Rate Error Type	Error Type Enumeration 1	Read / Write
0x286	Low Pressure Error Type	Error Type Enumeration 1	Read / Write
0x287	High Pressure Error Type	Error Type Enumeration 1	Read / Write
0x289	High Outlet Pressure Error Type	Error Type Enumeration 2	Read / Write
0x28A	Low Volume Error Type	Error Type Enumeration 1	Read / Write
0x28B	High Volume Error Type	Error Type Enumeration 1	Read / Write
0x28C	Low Computed Target Error Type	Error Type Enumeration 1	Read / Write

Output Bits 256-267	Description	Units *See Units Definitions, page 137	Read or Write
0x28D	High Computed Target Error Type	Error Type Enumeration 1	Read / Write
0x28E	Low Inlet Pressure Error Type	Error Type Enumeration 2	Read / Write
0x28F	High Inlet Pressure Error Type	Error Type Enumeration 2	Read / Write
0x292	Valve 1 Mode	Valve Mode Enumeration	Read / Write
0x293	Valve 2 Mode	Valve Mode Enumeration	Read / Write
0x294	Valve 3 Mode	Valve Mode Enumeration	Read / Write
0x295	Valve 4 Mode	Valve Mode Enumeration	Read / Write
0x296	Valve 1 10 VDC Analog Scale Flow rate	Volume: ##### (cc/sec); ##### (cc/min); Mass: ##### (g/sec); ##### (g/min)	Read / Write
0x297	Valve 2 10 VDC Analog Scale Flow rate	Volume: ##### (cc/sec); ##### (cc/min); Mass: ##### (g/sec); ##### (g/min)	Read / Write
0x298	Valve 3 10 VDC Analog Scale Flow rate	Volume: ##### (cc/sec); ##### (cc/min); Mass: ##### (g/sec); ##### (g/min)	Read / Write
0x299	Valve 4 10 VDC Analog Scale Flow rate	Volume: ##### (cc/sec); ##### (cc/min); Mass: ##### (g/sec); ##### (g/min)	Read / Write
0x29A	Valve 1 10 VDC Analog Scale Pressure	Pressure: ##### (psi); ###.# (bar); ##.## (Mpa)	Read / Write
0x29B	Valve 2 10 VDC Analog Scale Pressure	Pressure: ##### (psi); ###.# (bar); ##.## (Mpa)	Read / Write
0x29C	Valve 3 10 VDC Analog Scale Pressure	Pressure: ##### (psi); ###.# (bar); ##.## (Mpa)	Read / Write
0x29D	Valve 4 10 VDC Analog Scale Pressure	Pressure: ##### (psi); ###.# (bar); ##.## (Mpa)	Read / Write
0x302	Regulator Maintenance - Dispensed Volume*	Volume: ##### (gal(US)); ##### (gal(Uk)); ##### (Liters); Mass: ##### (lb), ##### (kg)	Read / Write
0x303	Flow meter Maintenance - Dispensed Volume*	Volume: ##### (gal(US)); ##### (gal(Uk)); ##### (Liters); Mass: ##### (lb), ##### (kg)	Read / Write

Output Bits 256-267	Description	Units *See Units Definitions, page 137	Read or Write
0x304	Supply Maintenance - Dispensed Volume*	Volume: ##### (gal(US)); ##### (gal(Uk)); ##### (Liters); Mass: ##### (lb), ##### (kg)	Read / Write
0x305	V/P Maintenance - Dispensed Volume*	Volume: ##### (gal(US)); ##### (gal(Uk)); ##### (Liters); Mass: ##### (lb), ##### (kg)	Read / Write
0x308	Valve 1 Maintenance - Dispensed Volume*	Volume: ##### (gal(US)); ##### (gal(Uk)); ##### (Liters); Mass: ##### (lb), ##### (kg)	Read / Write
0x309	Valve 2 Maintenance - Dispensed Volume*	Volume: ##### (gal(US)); ##### (gal(Uk)); ##### (Liters); Mass: ##### (lb), ##### (kg)	Read / Write
0x30A	Valve 3 Maintenance - Dispensed Volume*	Volume: ##### (gal(US)); ##### (gal(Uk)); ##### (Liters); Mass: ##### (lb), ##### (kg)	Read / Write
0x30B	Valve 4 Maintenance - Dispensed Volume*	Volume: ##### (gal(US)); ##### (gal(Uk)); ##### (Liters); Mass: ##### (lb), ##### (kg)	Read / Write
0x312	Regulator Maintenance - Dispense Time*	##### (hours)	Read / Write
0x313	Flow meter Maintenance - Dispense Time*	##### (hours)	Read / Write
0x314	Supply Maintenance - Dispense Time*	##### (hours)	Read / Write
0x315	V/P Maintenance - Dispense Time*	##### (hours)	Read / Write
0x318	Valve 1 Maintenance - Dispense Time*	##### (hours)	Read / Write
0x319	Valve 2 Maintenance - Dispense Time*	##### (hours)	Read / Write
0x31A	Valve 3 Maintenance - Dispense Time*	##### (hours)	Read / Write

Output Bits 256-267	Description	Units *See Units Definitions, page 137	Read or Write
0x31B	Valve 4 Maintenance - Dispense Time*	##### (hours)	Read / Write
0x800	Purge Definition - Volume	#####.# (cc)	Read / Write
0x801	Purge Definition - Pressure	Pressure: ##### (psi); ###.# (bar); ##.## (Mpa)	Read / Write
0x802	Purge Definition - Tolerances	Tolerances Type	Read / Write
0x803	Purge Definition - Duration	#### (seconds)	Read / Write
0x804	Style 1 Definition - Volume	#####.# (cc)	Read / Write
0x805	Style 1 Definition - Pressure	Pressure: ##### (psi); ###.# (bar); ##.## (Mpa)	Read / Write
0x806	Style 1 Definition - Tolerances	Tolerances Type	Read / Write
0x807	Style 1 Definition - Precharge Settings	Precharge Settings Type	Read / Write
0xBFC	Style 255 Definition - Volume	#####.# (cc)	Read / Write
0xBFD	Style 255 Definition - Pressure	Pressure: ##### (psi); ###.# (bar); ##.## (Mpa)	Read / Write
0xBFE	Style 255 Definition - Tolerances	Tolerances Type	Read / Write
0xBFF	Style 255 Definition - Precharge Settings	Precharge Settings Type	---
0xC04	Style 1 Definition - Name	STR_3_0	Read / Write
0xC05	Style 1 Definition - Name	STR_7_4	Read / Write
0xC06	Style 1 Definition - Name	STR_11_8	Read / Write
0xC07	Style 1 Definition - Name	STR_15_12	Read / Write
0xC3C	Style 15 Definition - Name	STR_3_0	Read / Write
0xC3D	Style 15 Definition - Name	STR_7_4	Read / Write
0xC3E	Style 15 Definition - Name	STR_11_8	Read / Write
0xC3F	Style 15 Definition - Name	STR_15_12	Read / Write

Output Bits 256-267	Description	Units *See Units Definitions, page 137	Read or Write
0x29E	Pressure Units	Pressure Units Enumeration	Read / Write
0x29F	Rate Units	Rate Units Enumeration	Read / Write
0x2A0	Maintenance Volume Units	Volume Units Enumeration	Read / Write
0x2A1	Maintenance Mass Units	Mass Units Enumeration	Read / Write
0x2A2	Maintenance Time Units	Mass Units Enumeration	Read / Write
0x2AD	Valve 1 Swirl Association (Swirl Zone)	Swirl Enumeration	Read / Write
0x2AE	Valve 2 Swirl Association (Swirl Zone)	Swirl Enumeration	Read / Write
0x2AF	Valve 3 Swirl Association (Swirl Zone)	Swirl Enumeration	Read / Write
0x2B0	Valve 4 Swirl Association (Swirl Zone)	Swirl Enumeration	Read / Write
0x2B5	End Job On Alarm	Boolean	Read / Write
0x3FB	Style Bits	###	Read / Write
0x115	Command Value	uint12	Read / Write
0x116	Error Reset / Remote Start	Dispense Control 2 Bit-field	Read / Write
0x118	Disable Dispensing	Boolean	Read / Write
0x3FF	Dispense Control	Dispense Control 1 Bit-field	Read / Write
0x0FB	Inlet Pressure	Pressure: #### (psi); ###.# (bar); ##.## (Mpa)	Read Only
0x0FC	Outlet Pressure	Pressure: #### (psi); ###.# (bar); ##.## (Mpa)	Read Only
0x0DC	Pressure Command	Pressure: #### (psi); ###.# (bar); ##.## (Mpa)	Read Only
0x403	Flowrate Command	##### cc/min	Read Only
0x404	Flowrate Actual	##### cc/min	Read Only
0x406	Fluid Plate Status 0	Fluid Plate Status 0 bitfield	Read Only
0x409	Fluid Plate Faults	Gateway Error Number	Read Only

Output Bits 256-267	Description	Units *See Units Definitions, page 137	Read or Write
0x0FF	Fluid Plate Dispensed Volume	#####.# (cc)	Read Only
0x0DB	Active Fault Error Code	Fault Error Code	Read Only
0x0F8	Fluid Plate Status Bits	Fluid Plate Status bit-field	Read Only
0x0FE	Requested Volume	#####.# (cc)	Read Only

* Maintenance dispensed volume/time can only be set to 0.

Swirl Commands

Output Bits 264-275	Description	Gateway Units	Read or Write
0x004	Software Part Number	STR_3_0	Read Only
0x005	Software Part Number	STR_7_4	Read Only
0x006	Software Part Number	STR_11_8	Read Only
0x007	Software Part Number	STR_15_12	Read Only
0x00B	Software Version	Version	Read Only
0x400	Swirl Speed Source	Speed Source Enumeration	Read / Write
0x401	Swirl Fixed Speed	##### (RPM)	Read / Write
0x403	Swirl Speed Scaling	### (percent)	Read / Write
0x404	Swirl Maintenance Time Advisory Limit	##### (hours)	Read / Write
0x3FF	Swirl - Actual Run Time	##### (hours)	Read / Write
0x2FC	Swirl Status Bits 1	Swirl Status Bit-field 1	Read Only
0x4FE	Swirl Actual Speed	##### (RPM)	Read Only
0x500	Swirl Control	Swirl Control Enumeration	Read / Write
0x501	Swirl Requested Speed	uint12	Read / Write

Units Definitions

Unit s String	Definition																																																																		
Command Value Source Enumeration	0 - Display, 1 - Command Cable, 2 - Gateway																																																																		
Dispense Control 1 Bitfield	<table border="0"> <tr> <td>Bit</td> <td>Function</td> <td>3</td> <td>Valve 2 On</td> <td>6</td> <td>Error Reset</td> </tr> <tr> <td>0</td> <td>Style Strobe</td> <td>4</td> <td>Valve 3 On</td> <td>7</td> <td>Remote Start/Purge</td> </tr> <tr> <td>1</td> <td>Dispense Complete</td> <td>5</td> <td>Valve 4 On</td> <td></td> <td></td> </tr> <tr> <td>2</td> <td>Valve 1 On</td> <td></td> <td></td> <td></td> <td></td> </tr> </table>	Bit	Function	3	Valve 2 On	6	Error Reset	0	Style Strobe	4	Valve 3 On	7	Remote Start/Purge	1	Dispense Complete	5	Valve 4 On			2	Valve 1 On																																														
Bit	Function	3	Valve 2 On	6	Error Reset																																																														
0	Style Strobe	4	Valve 3 On	7	Remote Start/Purge																																																														
1	Dispense Complete	5	Valve 4 On																																																																
2	Valve 1 On																																																																		
Dispense Control 2 Bitfield	Bit 14 - Error Reset, Bit 15 - Remote Start																																																																		
Dispense Trigger Source Enumeration	0 - Command Cable, 1 - Gateway, 2 - Combined, 3 - Command Cable 3x																																																																		
Error Type Enumeration 1	0 - None, 1 - Alarm, 2 - Deviation																																																																		
Error Type Enumeration 2	1 - Alarm, 2 - Deviation																																																																		
Fault Error Code	A 32-bit string in the format of 0xDDCCBBAA where 0xAA represents the most significant character in the string and 0xDD represents the least significant character in the string.																																																																		
Flow Meter Type Enumeration	1 - Volume, 2 - Mass																																																																		
Fluid Plate Status 0 Bitfield	<table border="0"> <tr> <td>Bit</td> <td>Function</td> <td>3</td> <td>Dispense In Process</td> <td>7</td> <td>Purge in Process/Remote Start in Process</td> </tr> <tr> <td>0</td> <td>Dispenser Ready</td> <td>4</td> <td>Dispensed Volume OK</td> <td></td> <td></td> </tr> <tr> <td>1</td> <td>Dispense No Alarm</td> <td>5</td> <td>---</td> <td></td> <td></td> </tr> <tr> <td>2</td> <td>Dispense No Error</td> <td>6</td> <td>Dispenser Purge Request</td> <td></td> <td></td> </tr> </table>	Bit	Function	3	Dispense In Process	7	Purge in Process/Remote Start in Process	0	Dispenser Ready	4	Dispensed Volume OK			1	Dispense No Alarm	5	---			2	Dispense No Error	6	Dispenser Purge Request																																												
Bit	Function	3	Dispense In Process	7	Purge in Process/Remote Start in Process																																																														
0	Dispenser Ready	4	Dispensed Volume OK																																																																
1	Dispense No Alarm	5	---																																																																
2	Dispense No Error	6	Dispenser Purge Request																																																																
Fluid Plate Status Bitfield	<table border="0"> <tr> <td>Bit</td> <td>Function</td> <td>11</td> <td>Alarm Active</td> <td>24</td> <td>Valve 3 Swirl Installed</td> </tr> <tr> <td>0-2</td> <td>Operation Mode (see Valve Mode Enumeration)</td> <td>12</td> <td>Deviation Active</td> <td>25</td> <td>Valve 4 Swirl Installed</td> </tr> <tr> <td>3</td> <td>Precharge Active</td> <td>13</td> <td>Advisory Active</td> <td>26</td> <td>Valve 1 Swirl Active</td> </tr> <tr> <td>4</td> <td>Valve 1 State</td> <td>14</td> <td>Dispensing Disabled</td> <td>27</td> <td>Valve 2 Swirl Active</td> </tr> <tr> <td>5</td> <td>Valve 2 State</td> <td>15</td> <td>Fluid Plate Enabled</td> <td>28</td> <td>Valve 3 Swirl Active</td> </tr> <tr> <td>6</td> <td>Valve 3 State</td> <td>16</td> <td>Flowmeter Enabled</td> <td>29</td> <td>Valve 4 Swirl Active</td> </tr> <tr> <td>7</td> <td>Valve 4 State</td> <td>17</td> <td>Inlet Sensor Enabled</td> <td>30</td> <td>Fault Reset</td> </tr> <tr> <td>8</td> <td>Ready to Dispense</td> <td>18</td> <td>Heated Plate</td> <td>31</td> <td>Remote Start/Purge</td> </tr> <tr> <td>9</td> <td>In Job Cycle</td> <td>19</td> <td>Integrator Enabled</td> <td></td> <td></td> </tr> <tr> <td>10</td> <td>Job Cycle Complete</td> <td>22</td> <td>Valve 1 Swirl Installed</td> <td></td> <td></td> </tr> <tr> <td></td> <td></td> <td>23</td> <td>Valve 2 Swirl Installed</td> <td></td> <td></td> </tr> </table>	Bit	Function	11	Alarm Active	24	Valve 3 Swirl Installed	0-2	Operation Mode (see Valve Mode Enumeration)	12	Deviation Active	25	Valve 4 Swirl Installed	3	Precharge Active	13	Advisory Active	26	Valve 1 Swirl Active	4	Valve 1 State	14	Dispensing Disabled	27	Valve 2 Swirl Active	5	Valve 2 State	15	Fluid Plate Enabled	28	Valve 3 Swirl Active	6	Valve 3 State	16	Flowmeter Enabled	29	Valve 4 Swirl Active	7	Valve 4 State	17	Inlet Sensor Enabled	30	Fault Reset	8	Ready to Dispense	18	Heated Plate	31	Remote Start/Purge	9	In Job Cycle	19	Integrator Enabled			10	Job Cycle Complete	22	Valve 1 Swirl Installed					23	Valve 2 Swirl Installed		
Bit	Function	11	Alarm Active	24	Valve 3 Swirl Installed																																																														
0-2	Operation Mode (see Valve Mode Enumeration)	12	Deviation Active	25	Valve 4 Swirl Installed																																																														
3	Precharge Active	13	Advisory Active	26	Valve 1 Swirl Active																																																														
4	Valve 1 State	14	Dispensing Disabled	27	Valve 2 Swirl Active																																																														
5	Valve 2 State	15	Fluid Plate Enabled	28	Valve 3 Swirl Active																																																														
6	Valve 3 State	16	Flowmeter Enabled	29	Valve 4 Swirl Active																																																														
7	Valve 4 State	17	Inlet Sensor Enabled	30	Fault Reset																																																														
8	Ready to Dispense	18	Heated Plate	31	Remote Start/Purge																																																														
9	In Job Cycle	19	Integrator Enabled																																																																
10	Job Cycle Complete	22	Valve 1 Swirl Installed																																																																
		23	Valve 2 Swirl Installed																																																																
Job End Mode Enumeration	0 - Timer, 1 - Gateway																																																																		
Maintenance Units Enumeration	0 - Volume, 1 - Mass, 2 - Time																																																																		
Mass Units Enumeration	0 - lb, 1 - kg																																																																		
Precharge Settings Type	<p>A 32 bit value in the format of 0xDDCCBBA:</p> <p>0xA.....Precharge mode enumeration: 0 - Display, 1 - Gateway, 2 - Valve 1</p> <p>0xB...Precharge valve opening duration (ms)</p> <p>0xCC.....Precharge scale - valve closed (%)</p> <p>0xDD.....Precharge scale - valve opening (%)</p>																																																																		
Pressure Units Enumeration	0 - psi, 1 - bar, 2 - MPa																																																																		
Rate Units Enumeration	0 - x/min, 1 - x/sec																																																																		
sint32	A 32 bit positive or negative value																																																																		
Speed Source Enumeration	0 - Display, 1 - Gateway																																																																		
STR_X_Y	A 32 bit value where X signifies which character in the string that the most significant byte represents and Y signifies which character in the string that the least significant byte represents.																																																																		
Swirl Control Enumeration	0 - Swirl Enable																																																																		
Swirl Enumeration	0 - None, 1 - Swirl 1, 2 - Swirl 2, 3 - Swirl 3, 4 - Swirl 4																																																																		
Swirl Status Bitfield 1	0 - Swirl Active, 1 - Swirl Ready, 2 - Swirl Enabled																																																																		
Tolerances Type	A 32 bit value in the format of 0x000BBAA where 0xAA represents the low tolerance (%) and 0xBB represents the high tolerance (%). A value of 0 means that tolerance is disabled.																																																																		
Valve Mode Enumeration	0 - Pressure, 1 - Bead, 2 - Shot, 3 - Full Open																																																																		
uint12	A 12 bit positive value																																																																		
uint32	A 32 bit positive value																																																																		
Version	A 32 bit value in the format of 0x00CCBBAA where 0xAA represents the major version, 0xBB represents the minor version and 0xCC represents the build version.																																																																		
Volume Units Enumeration	0 - gal(US), 1 - gal(UK), 2 - Liters																																																																		

Appendix D - I/O Signal Descriptions

This section provides details about the CGM and DGM Automation Input and Output signals.

Automation Inputs

Dispenser (Fluid Plate) Ready

This signal is 0 on power up. This signal will be 1 under in the following conditions:

- The system is in an active state, and
- The dispenser (fluid plate) does not have an active Alarm (Deviations have no effect).

Dispenser (Fluid Plate) No Alarm

For systems with a CGM, this signal will be 1 under the following condition:

- The system does not have an alarm.
- For systems with a DGM, this signal can be configured to be active high or active low. See **Discrete Gateway (Automation) Setup Screen**, page 104.

Dispenser (Fluid Plate) No Error

For systems with a CGM, this signal will be 1 under the following condition:

- The system does not have an error (alarm, deviation, or advisory).
- For systems with a DGM, this signal can be configured to be active high or active low. See **Discrete Gateway (Automation) Setup Screen**, page 104.

Dispense in Process

This signal is 0 on power up. This signal will be 1 under the following condition:

- The system is in the middle of a job.

Dispense Volume OK

This signal will be 1 under the following conditions:

- The system has completed a job, and
- the volume of the job is within the tolerance specified, and
- the style strobe is 1.

Dispenser (Fluid Plate) Purge Request

This signal is 1 on power up if a purge interval has been defined, 0 on power up otherwise. Any dispensing will turn off this bit and reset the purge timer. This signal will be 1 under the following condition:

- The system purge interval timer has expired.

Dispenser (Fluid Plate) Remote Start / Purge in Process

This signal is 0 on power up. This signal will be 1 under the following conditions:

- A remote start sequence is in process. This signal shall remain asserted until the dispense equipment has achieved Dispense Ready status.
- A purge sequence is in process. This signal shall remain asserted until the purge sequence is complete.

Units

All units settings are set in the Advanced Display Module. The following signals are used to communicate this information to the automation controller.

Pressure Units

Value	Units
0	psi
1	bar
2	MPa
3	reserve

Errors

Error numbers are formed by 8 bits. This is the error number in the system.

Automation Outputs

Style

The desired style of the next job. These 8 bits are read at the start of a job to determine the selected style.

Style Strobe

This bit is used to start a new job. A new job is started when the style strobe changes from 0 to 1.

Dispense Complete

This bit is used to signal the end of a job. A job is ended when this signal changes from 0 to 1.

Dispense Valve x On

These 4 bits are used to signal the turn on and turn off of each of the 4 dispense valves on the applicable fluid plate.

Command Value

This 12 bit value indicates the analog command value from 0-10Volts (0x000-0xFFFF). This analog value is scaled to a flow rate (in bead mode) or pressure (in pressure or shot mode) command based on the configured scale factor.

Error Reset / Cancel Job

If the “End Job On Alarm” setting is enabled:

- If in a job, setting this bit will cancel the current job.
- If not in a job, setting this will reset errors.

If the “End Job On Alarm” setting is disabled:

- Setting this bit will reset errors regardless of job status.

Remote Start / Purge

This bit is used to restart the dispense system from any “not-ready” state. If the system is already in a Dispense Ready state, this signal shall initiate a purge based on the configured purge parameters.

Swirl X Enable

This bit is used to signal the on and off status of each swirl dispenser motor.

Swirl Command Value

This 12-bit value indicates a swirl speed command from 0-10 volts. 0 volts (0x000) represents a speed of 6,600 rpm and 10 volts (0xFFFF) represents 24,000 rpm.

Dispense Valve X Precharge On

These 4 bits are used to turn on precharge for each of the 4 dispense valves when the precharge mode is set to Gateway.

Technical Data

*Minimum Flow Rates	25 cc/minute with high-resolution (ambient) helical flow meter 50 cc/minute with heated helical flow meter
*Maximum Flow Rates	7500 cc/minute with high-resolution (ambient) helical flow meter 22,500 cc/minute with heated helical flow meter 37,500 cc/minute with separate flow meter
Maximum Fluid Working Pressure	
feed pressure to fluid plate (cartridge regulator)	6000 psi (41 MPa, 414 bar)
feed pressure to fluid plate (mastic regulator)	5000 psi (35 MPa, 345 bar)
at regulator outlet	4500 psi (31 MPa, 310 bar)
at regulator outlet with electric heat components	3500 psi (24 MPa, 241 bar)
Minimum Fluid Working Pressure (at regulator outlet)	100 psi (0.7 MPa, 7.0 bar)
Air Supply Pressure Range	60-120 psi (0.4 - 0.8 MPa, 4.1- 8.3 bar) - 10 Micron filtration required
Fluid Filtration Required	30 mesh (500 micron) minimum
*Viscosity Range of Fluids	10,000 to 1,000,000 cps with helical flow meter
*Minimum Dispensed Shot Size	3 cc with high-resolution (ambient) helical flow meter 6 cc with heated helical flow meter
Wetted Parts (meters and fluid plates)	303, 304, 321, 17- 4 stainless steel; tungsten carbide, PTFE, steel, fluoroelastomer
Power Requirements	
100-240 Vac	full load-1.4A, fuse rating-2.5A
24 Vdc	full load-4A, fuse rating-4A
Power Supply Voltage Range	100-240 Vac, 50-60 Hz, single phase
Operating Temperature Range	
control center	40°F (4°C) - 120°F (49°C)
heated fluid plate	40°F (4°C) - 400°F (204°C)
ambient fluid plate	40°F (4°C) - 120°F (49°C)
Operating Humidity Range	0 - 90% non-condensing

* Flow rates and viscosities are general estimates. Flow rates drop as viscosity increases. Fluids are expected to shear under pressure. New applications or fluids should always be tested to determine proper line sizes and equipment selections. See your Graco authorized distributor for other capabilities.

Control Center Assembly Technical Data

	100 - 240 Vac Assemblies	24 Vdc Assembly
Voltage	100-240 Vac	24 Vdc
Phase	1	---
Frequency	50-60 Hz	---
Full Load Current	1.4 A	4.0 A
Fuse Rating	250 Vac, 2.5A T	125 Vac, 4A F

Fluid Plate Assembly Technical Data

Mounting dimensions and parts breakdowns for the fluid plate assemblies are in the installation section of this manual.

	Cartridge Regulator	Mastic Regulator
Regulator Manual	308647	307517
Weight - No Flow Meter	25.5 lb (11.6 kg)	33 lb (15 kg)
Weight - Helical	40 lb (18 kg)	48 lb (22 kg)
Fluid Port Inlet	Helical: 3/4 in. npt(f)	3/4 in. npt(f)
Fluid Port Outlet	1/2 in. npt(f)	3/4 in. npt(f)
Maximum Fluid Working Pressure*	See Models on page 4	See Models on page 4
Air Supply	1/4 in. npt(f)	1/4 in. npt(f)
Maximum Air Working Pressure	100 psi (0.7 MPa, 7.0 bar)	100 psi (0.7 MPa, 7.0 bar)
Minimum Air Working Pressure	60 psi (410 kPa, 4.1 bar)	60 psi (410 kPa, 4.1 bar)
Fluid Operating Temperature	Ambient 40° - 120°F (4° - 50°C)	Heated 40° - 400°F (4° - 204°C) Ambient 40° - 120°F (4° - 50°C)
Minimum Flow Rate - Helical	Ambient 25 cc/min	Heated 50 cc/min Ambient 25 cc/min

*Maximum system pressure depends on dispense valve.

Air outlets, open and close to dispense valve	5/32 in. (4 mm) tube fittings
Electric Power Requirements	24 Vdc or 100-240 Vac
Power Supplied to Dispense Valve Solenoid(s)	24 Vdc
Fluid Specifications	For use when dispensing fluids that meet at least one of the following conditions for non-flammability: <ul style="list-style-type: none"> The fluid has a flash point above 140° F (60° C) and a maximum organic solvent concentration of 20% by weight, per ASTM Standard D93. The fluid does not sustain burning when tested per ASTM Standard D4206 Sustained Burn Test.
Ambient Air Temperature Range	40° to 120° (4° to 50° C)

Swirl Dispenser Technical Data

Refer to manual 309403.

Graco Standard Warranty

Graco warrants all equipment referenced in this document which is manufactured by Graco and bearing its name to be free from defects in material and workmanship on the date of sale to the original purchaser for use. With the exception of any special, extended, or limited warranty published by Graco, Graco will, for a period of twelve months from the date of sale, repair or replace any part of the equipment determined by Graco to be defective. This warranty applies only when the equipment is installed, operated and maintained in accordance with Graco's written recommendations.

This warranty does not cover, and Graco shall not be liable for general wear and tear, or any malfunction, damage or wear caused by faulty installation, misapplication, abrasion, corrosion, inadequate or improper maintenance, negligence, accident, tampering, or substitution of non-Graco component parts. Nor shall Graco be liable for malfunction, damage or wear caused by the incompatibility of Graco equipment with structures, accessories, equipment or materials not supplied by Graco, or the improper design, manufacture, installation, operation or maintenance of structures, accessories, equipment or materials not supplied by Graco.

This warranty is conditioned upon the prepaid return of the equipment claimed to be defective to an authorized Graco distributor for verification of the claimed defect. If the claimed defect is verified, Graco will repair or replace free of charge any defective parts. The equipment will be returned to the original purchaser transportation prepaid. If inspection of the equipment does not disclose any defect in material or workmanship, repairs will be made at a reasonable charge, which charges may include the costs of parts, labor, and transportation.

THIS WARRANTY IS EXCLUSIVE, AND IS IN LIEU OF ANY OTHER WARRANTIES, EXPRESS OR IMPLIED, INCLUDING BUT NOT LIMITED TO WARRANTY OF MERCHANTABILITY OR WARRANTY OF FITNESS FOR A PARTICULAR PURPOSE.

Graco's sole obligation and buyer's sole remedy for any breach of warranty shall be as set forth above. The buyer agrees that no other remedy (including, but not limited to, incidental or consequential damages for lost profits, lost sales, injury to person or property, or any other incidental or consequential loss) shall be available. Any action for breach of warranty must be brought within two (2) years of the date of sale.

GRACO MAKES NO WARRANTY, AND DISCLAIMS ALL IMPLIED WARRANTIES OF MERCHANTABILITY AND FITNESS FOR A PARTICULAR PURPOSE, IN CONNECTION WITH ACCESSORIES, EQUIPMENT, MATERIALS OR COMPONENTS SOLD BUT NOT MANUFACTURED BY GRACO. These items sold, but not manufactured by Graco (such as electric motors, switches, hose, etc.), are subject to the warranty, if any, of their manufacturer. Graco will provide purchaser with reasonable assistance in making any claim for breach of these warranties.

In no event will Graco be liable for indirect, incidental, special or consequential damages resulting from Graco supplying equipment hereunder, or the furnishing, performance, or use of any products or other goods sold hereto, whether due to a breach of contract, breach of warranty, the negligence of Graco, or otherwise.

FOR GRACO CANADA CUSTOMERS

The Parties acknowledge that they have required that the present document, as well as all documents, notices and legal proceedings entered into, given or instituted pursuant hereto or relating directly or indirectly hereto, be drawn up in English. Les parties reconnaissent avoir convenu que la rédaction du présente document sera en Anglais, ainsi que tous documents, avis et procédures judiciaires exécutés, donnés ou intentés, à la suite de ou en rapport, directement ou indirectement, avec les procédures concernées.

Graco Information

For the latest information about Graco products, visit www.graco.com.

TO PLACE AN ORDER, contact your Graco distributor or call to identify the nearest distributor.

Phone: 612-623-6921 **or Toll Free:** 1-800-328-0211 **Fax:** 612-378-3505

All written and visual data contained in this document reflects the latest product information available at the time of publication. Graco reserves the right to make changes at any time without notice.

For patent information, see www.graco.com/patents.

Original instructions. This manual contains English. MM 3A2098

Graco Headquarters: Minneapolis

International Offices: Belgium, China, Japan, Korea

GRACO INC. AND SUBSIDIARIES • P.O. BOX 1441 • MINNEAPOLIS MN 55440-1441 • USA

Copyright 2011, Graco Inc. All Graco manufacturing locations are registered to ISO 9001.

www.graco.com

Revised August 2014